

# DAVOS - 120/60

PL: INSTRUKCJA MONTAŻU  
 D: MONTAGEANLEITUNG  
 GB: ASSEMBLY MANUAL  
 NL: HANDLEIDING VOOR DE MONTAGE  
 F: MODEL D'EMPLOI  
 SK: NÁVOD NA MONTÁŽ  
 CZ: NÁVOD K MONTÁŽI  
 HU: SZERELÉSI ÚTMUTATÓ  
 HR: UPUTE ZA MONTAŽU

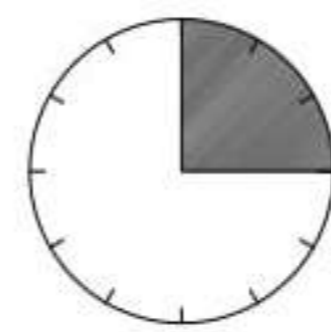

180 minut  
 180 minuten  
 180 minutes  
 180 minutes

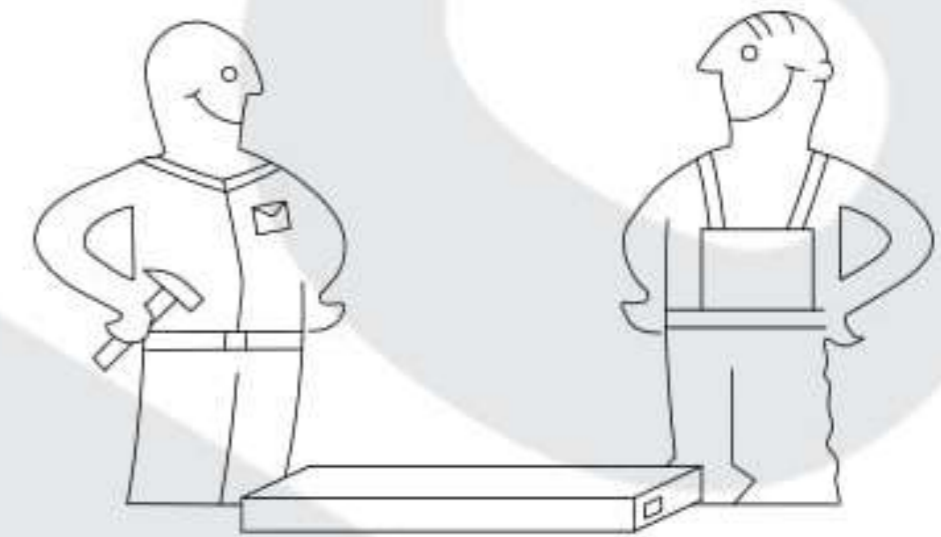
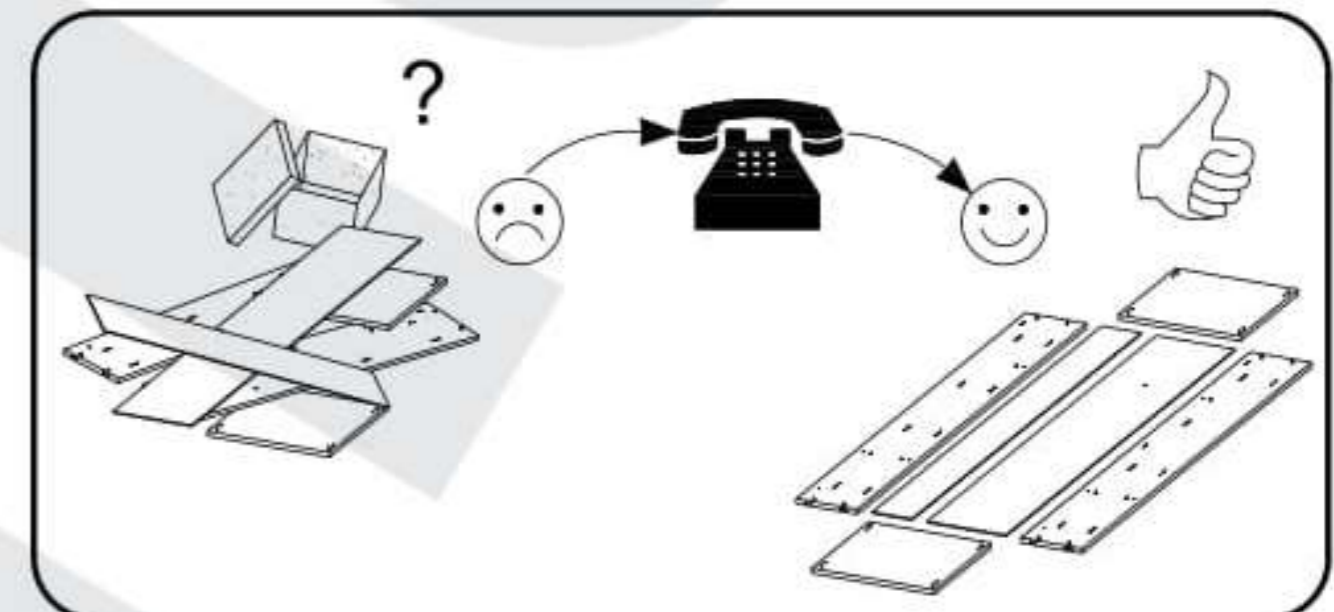
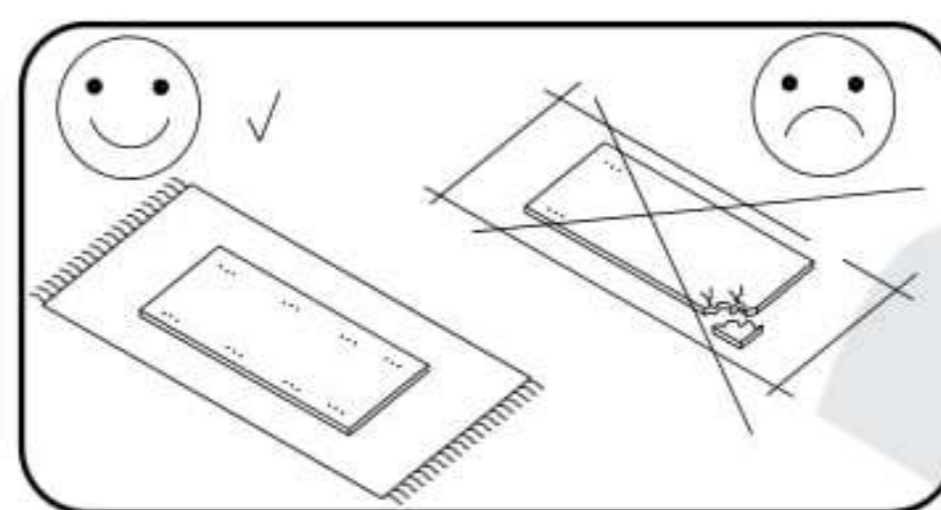
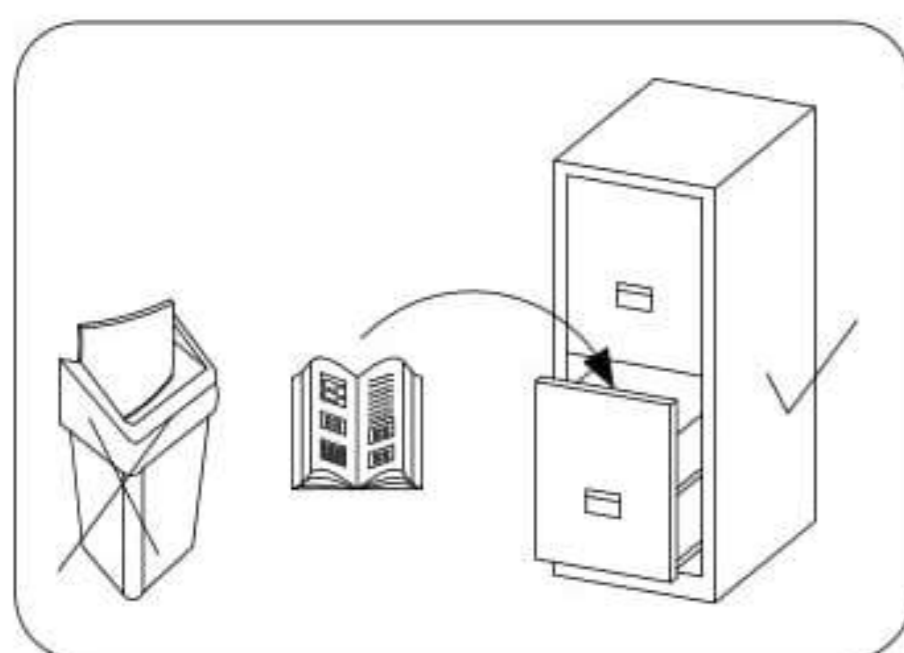
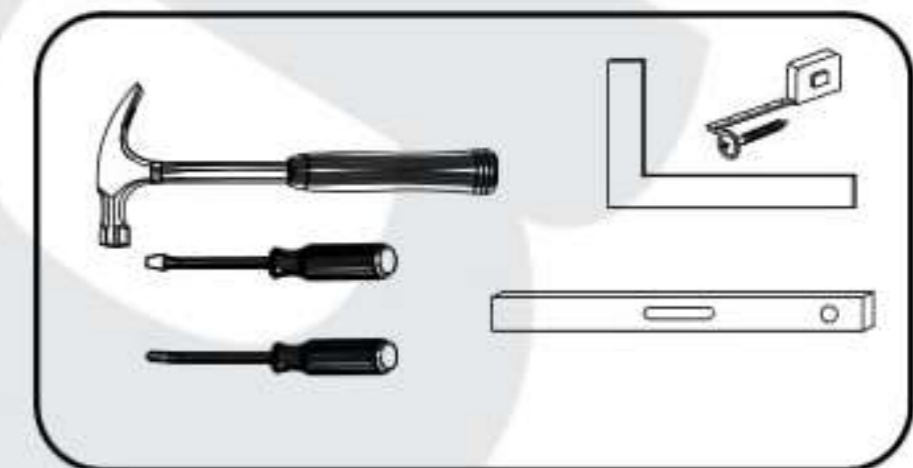

**Uwaga / Achtung / Caution / Opgelet / Attention /  
 Pozor / Pozor / Vigyázat / Pažnja**











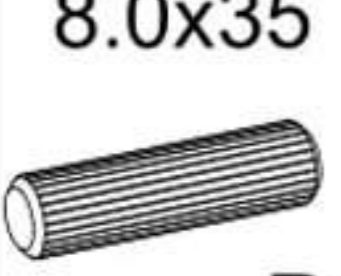

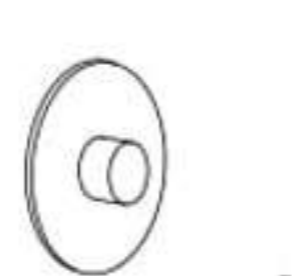



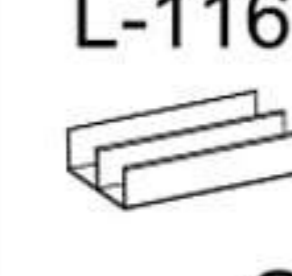

	Czyszczenie należy wykonać wyłącznie za pomocą ściereczki lub lekko nawilżonego ręcznika. Nie stosować środków czyszczących do szorowania.
<b>PL</b>	Szanowny kliencie, jeśli podczas montażu stwierdzisz uszkodzenie lub brak części proszę podać jej kod alfanumeryczny lub zaznaczyć ją na instrukcji montażu i przesłać wraz z protokołem reklamacyjnym.
<b>D</b>	Bitte nur mit einem Staubtuch oder leicht feuchtem Lappen reinigen. Keine scheuerenden Putzmittel verwenden. Sehr geehrter Kunde, sollte ein Teil fehlen oder beschädigt sein, kreuzen Sie dies bitte deutlich auf der Montageanleitung an und schicken Sie die Montageanleitung mit ein.
<b>GB</b>	Please only clean with a duster or a damp cloth. Do not use any abrasive cleaners. Dear customer, should there be any piece missing or damaged, kindly mark this piece clearly on the attached assembly instructions and return them to us.
<b>NL</b>	Reinig alleen met een stofdoek of een lichtjes vochtige doek. Gebruik geen schurende poetsmiddelen. Geachte klant, in het geval van beschadiging of ontbrekende onderdelen tijdens de montage, gelieve de alfanumerieke code in de montagehandleiding te vermelden of te markeren en samen met het klachtenprotocol mee te sturen.
<b>F</b>	Le nettoyage se fait uniquement à l'aide d'un torchon ou d'une serviette légèrement mouillée. Cher client, en cas de dommages ou de pièces manquantes lors du montage, veuillez fournir ou marquer le code alphanumérique dans le manuel de montage et l'envoyer avec le protocole de réclamation
<b>SK</b>	Nábytok by sa mal čistiť iba prachovkou alebo mierne navlhčenou handričkou. Nepoužívajte žiadne abrazívne čistiace prostriedky. Vážený zákazník, ak počas montáže zistíte, že niektorá časť chýba alebo je poškodená, vyznačte ju na montážnom návode a zdokumentované (odfotené) to zašlite na naše reklamačné oddelenie.

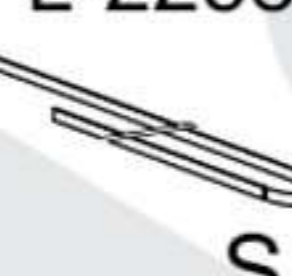

<b>CZ</b>	Nábytek by se měl čistit pouze prachovkou nebo mírně navlhčeným hadříkem. Nepoužívejte žádné abrazivní čisticí prostředky.
	Vážený zákazníku, pokud během montáže zjistíte, že některá část chybí nebo je poškozena, vyznačte ji na montážním návodu a zdokumentované (vyfocené) to zašlete na naše reklamační oddělení.
<b>HU</b>	A bútort csak portórlóval, illetve enyhén nedves ronggyal ajánljuk tisztítani. Ne használjon semmilyen agresszív tisztítószeret.
	Kedves Vásárló, amennyiben az összeszerelés során kiderül, hogy a termék bármelyik része hiányzik vagy sérült, kérem jelölje be azt a szerelési útmutatón, majd dokumentálja (fényképezze le) a hibás részt, így küldje be a reklamációt a részünkre.
<b>HR</b>	Čišćenje se smije vršiti samo krpom ili blago navlaženim ručnikom. Nemojte koristiti sredstva za čišćenje.
	Poštovani kupče, ako tijekom sastavljanja nađete oštećeni dio ili dio koji nedostaje, molimo da dostavite njegov alfanumerički kod ili ga označite u priručniku za sastavljanje i pošaljite ga zajedno s protokolom reklamacije.

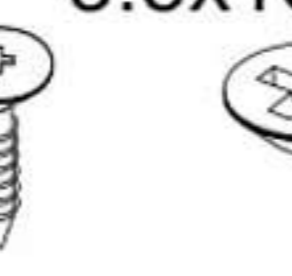
## Akcesoria / Zubehör / Accessories / Accessoires / Accessories / Príslušenstvo / Příslušenství / Tartozékok / Pribor

 8.0x35 D	 A	 B	 X	 N	 L-670 V1	 WD	 WG	 L-1166 SG	 L-1166 SD
20	60	60	40	4	2	4	4	1	1
 S1	 L-2258 DP	 L-1160 Y	 L-2258 SP	 4.0x25 P1	 M	 H	 3.5x16 H		 3.5x16 HC
110	4	3	4	16	8	52		54	

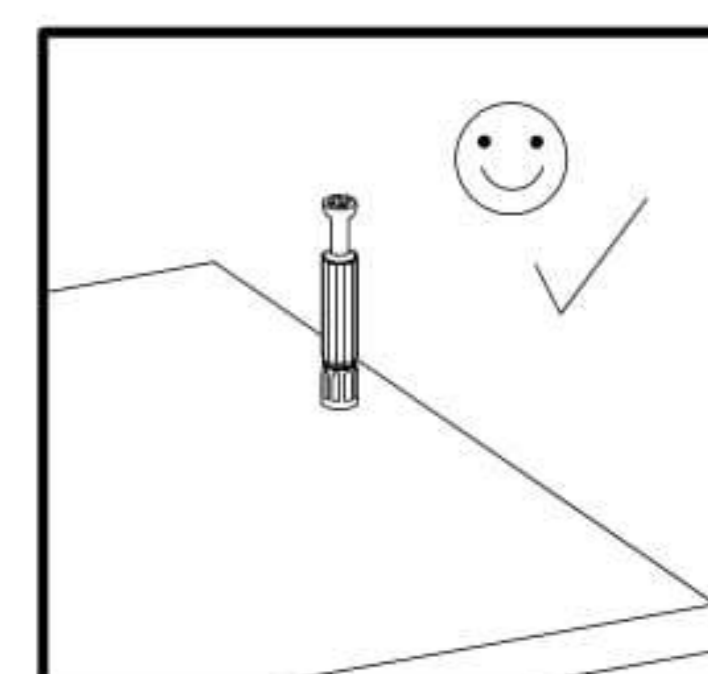
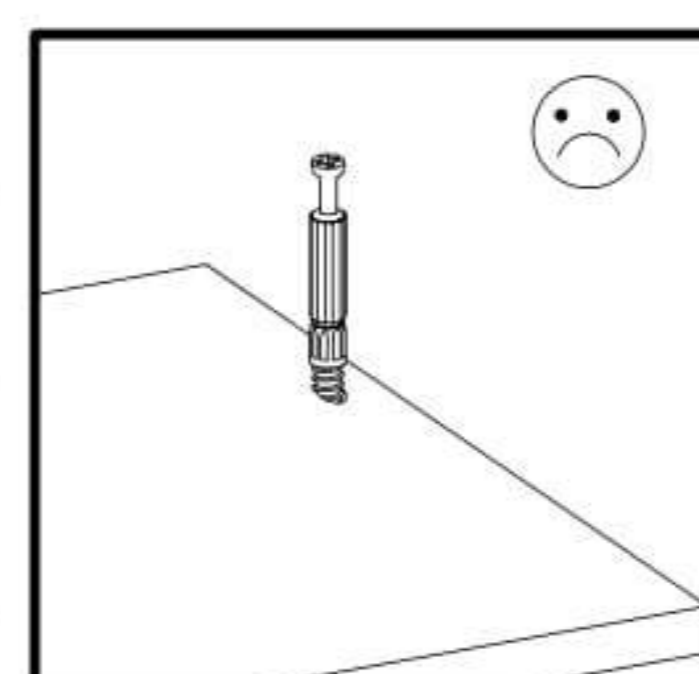
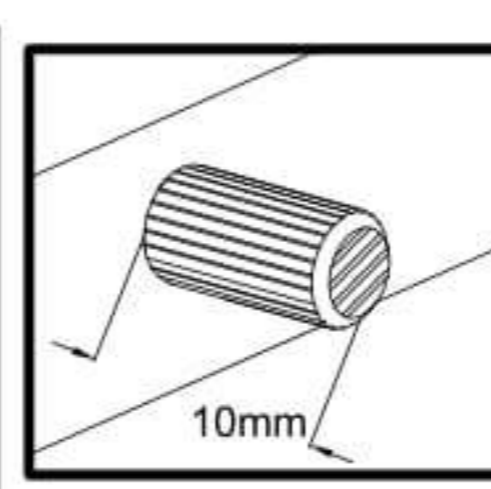
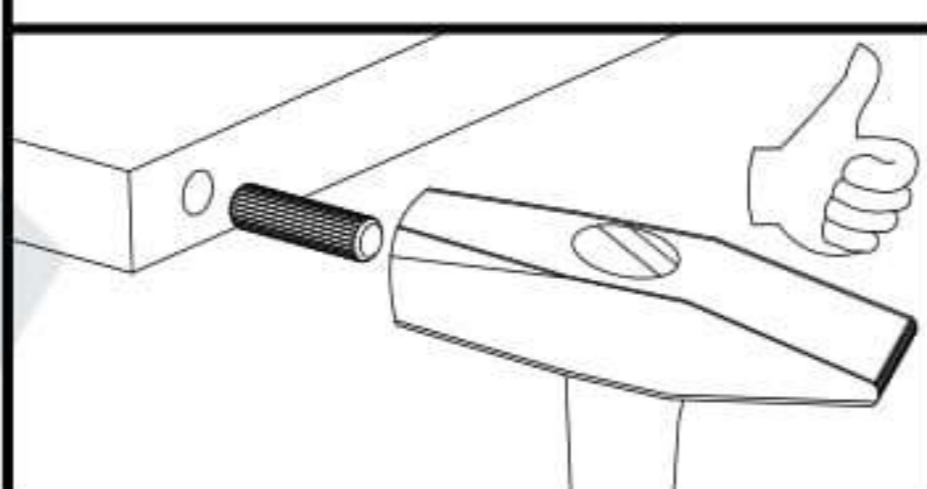
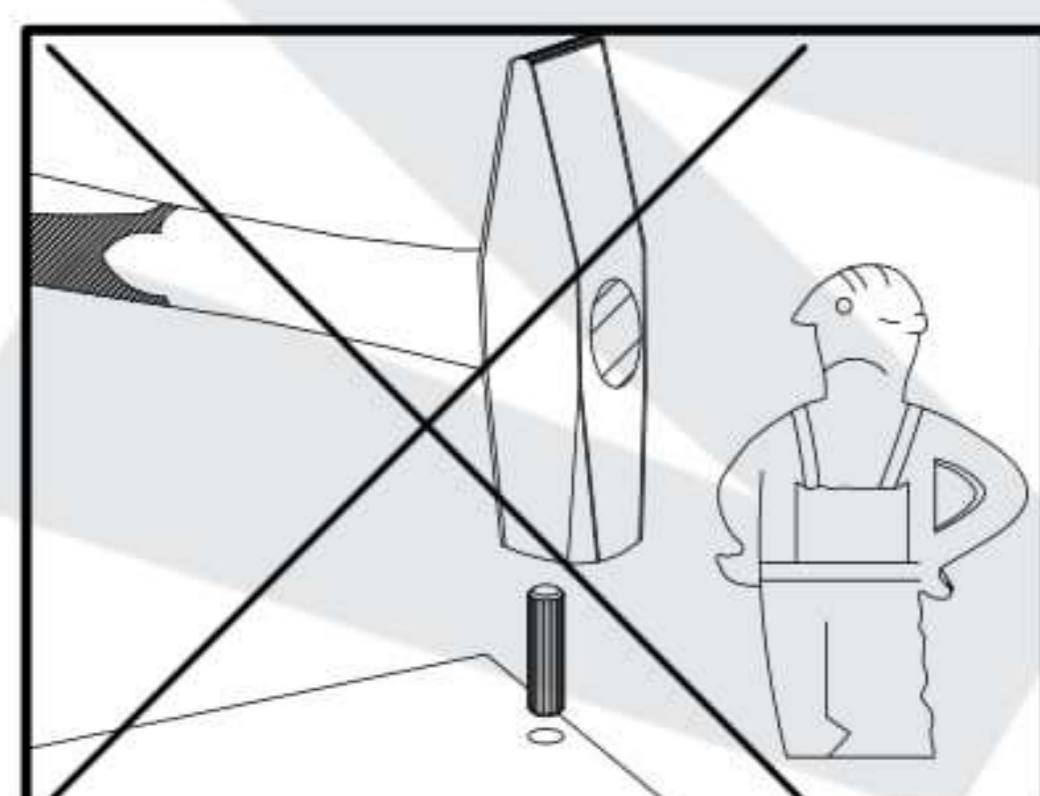



Opcja 1 / Možnosť 1 /  
Možnost 1 / 1. Lehetőség

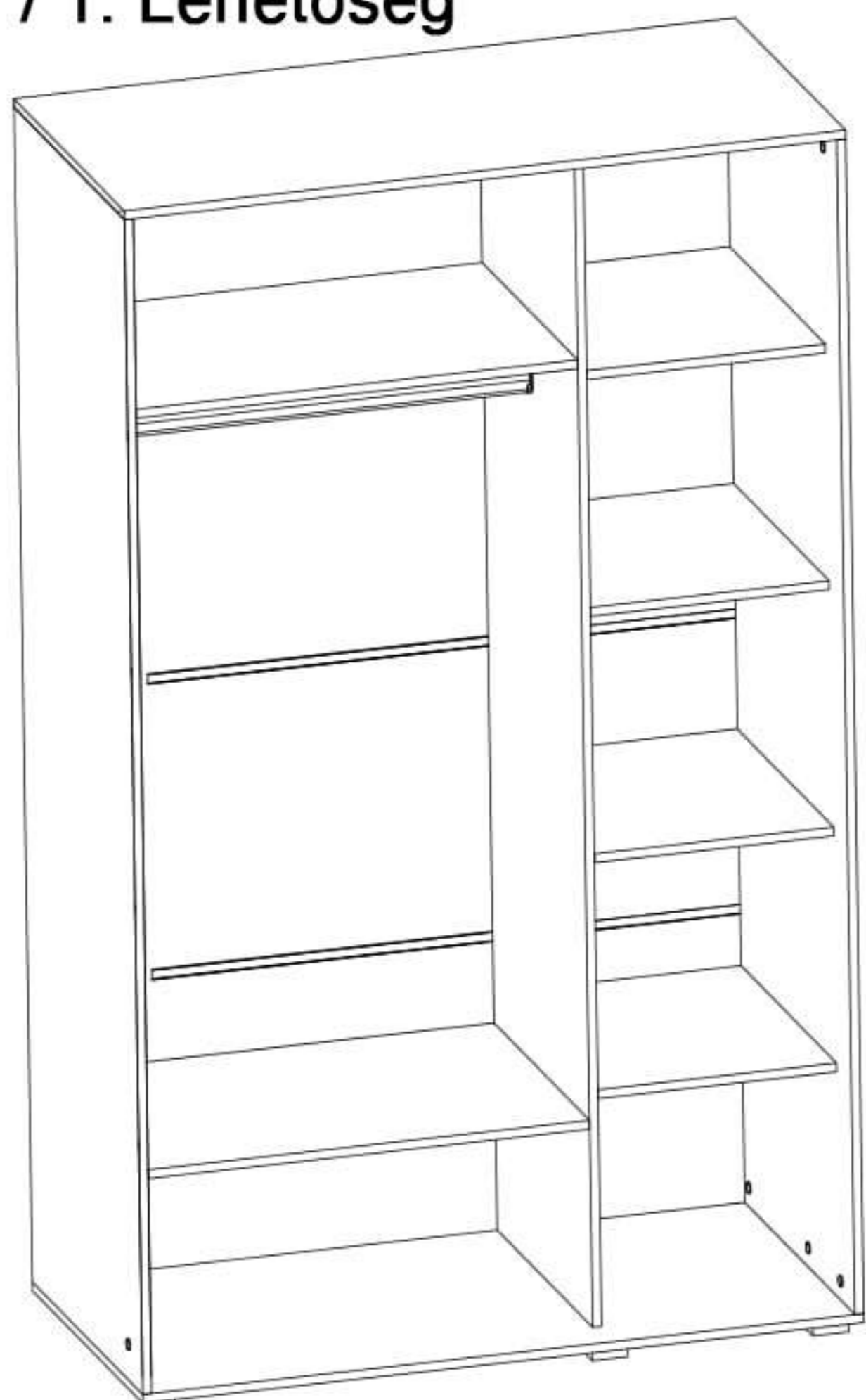

Opcja 2 / Možnosť 2 /  
Možnost 2 / 2. Lehetőség

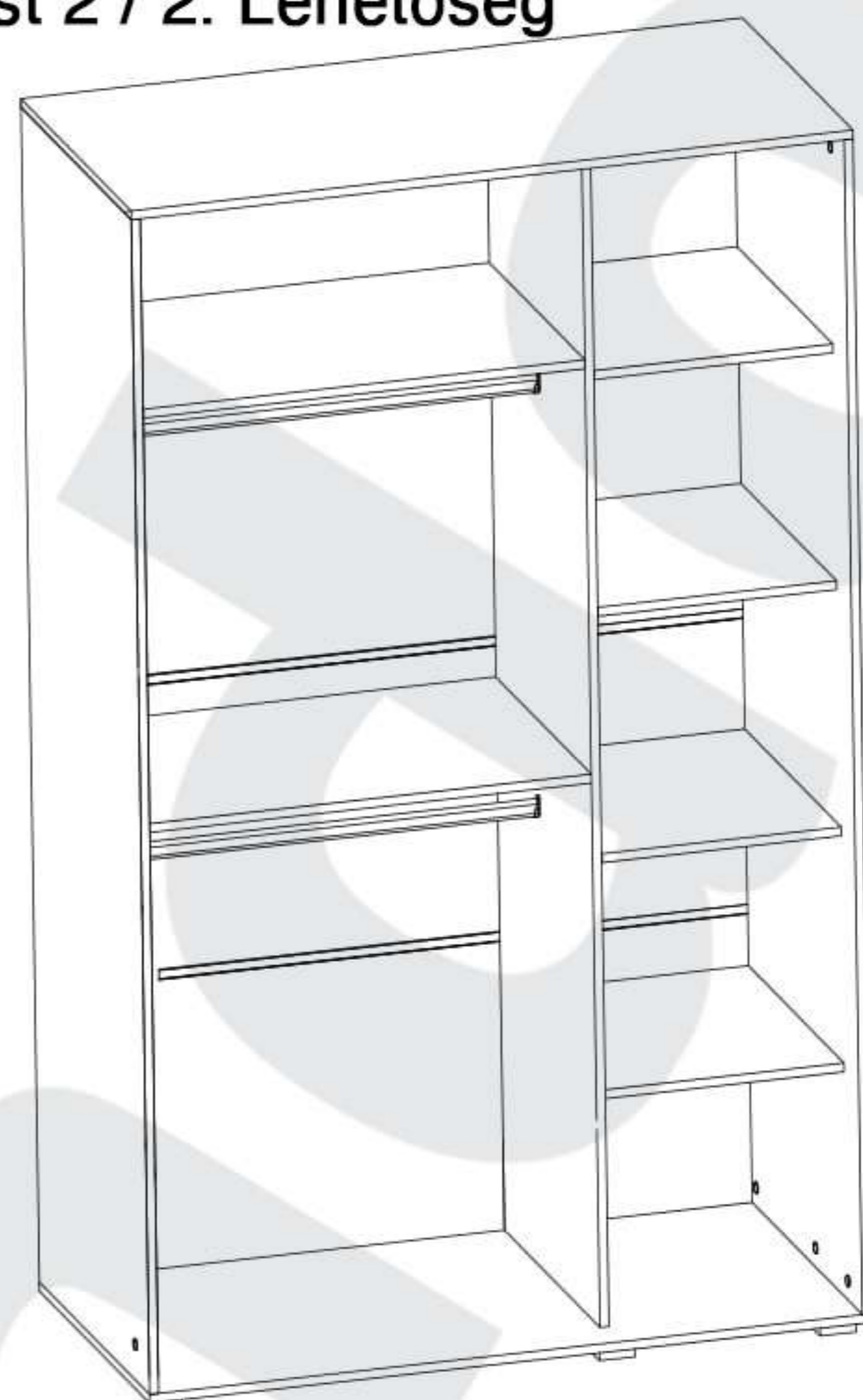

1.	1	1202	602	16
2.	1	1202	602	16
3.	1	2300	600	16
4.	1	2300	600	16
6.	1	2300	490	16
7.	4	476	480	16
8.	2	675	480	16
9.	4	1195	580	3
10.	1	2258	600	16
11.	1	2258	600	16

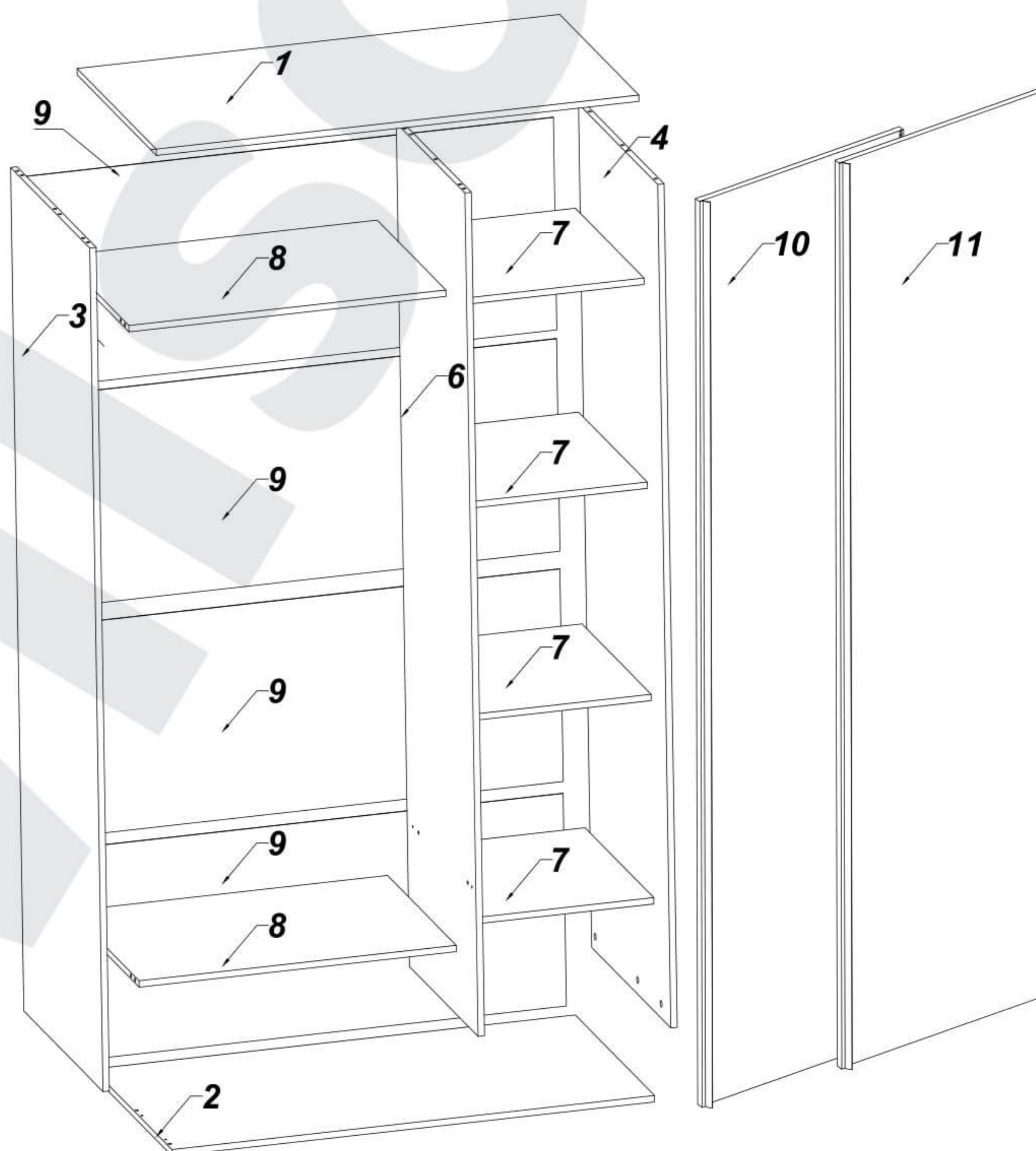



1

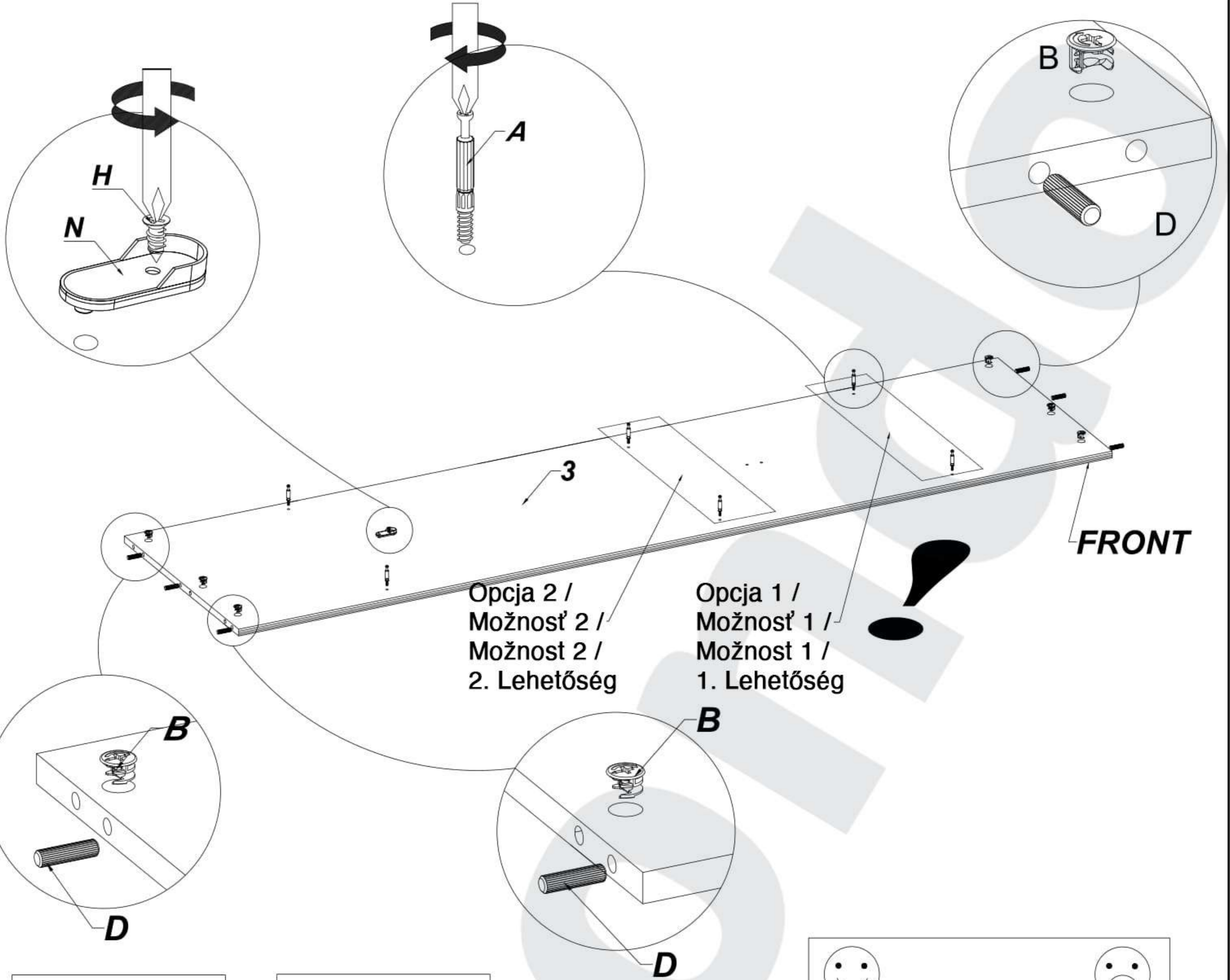

2

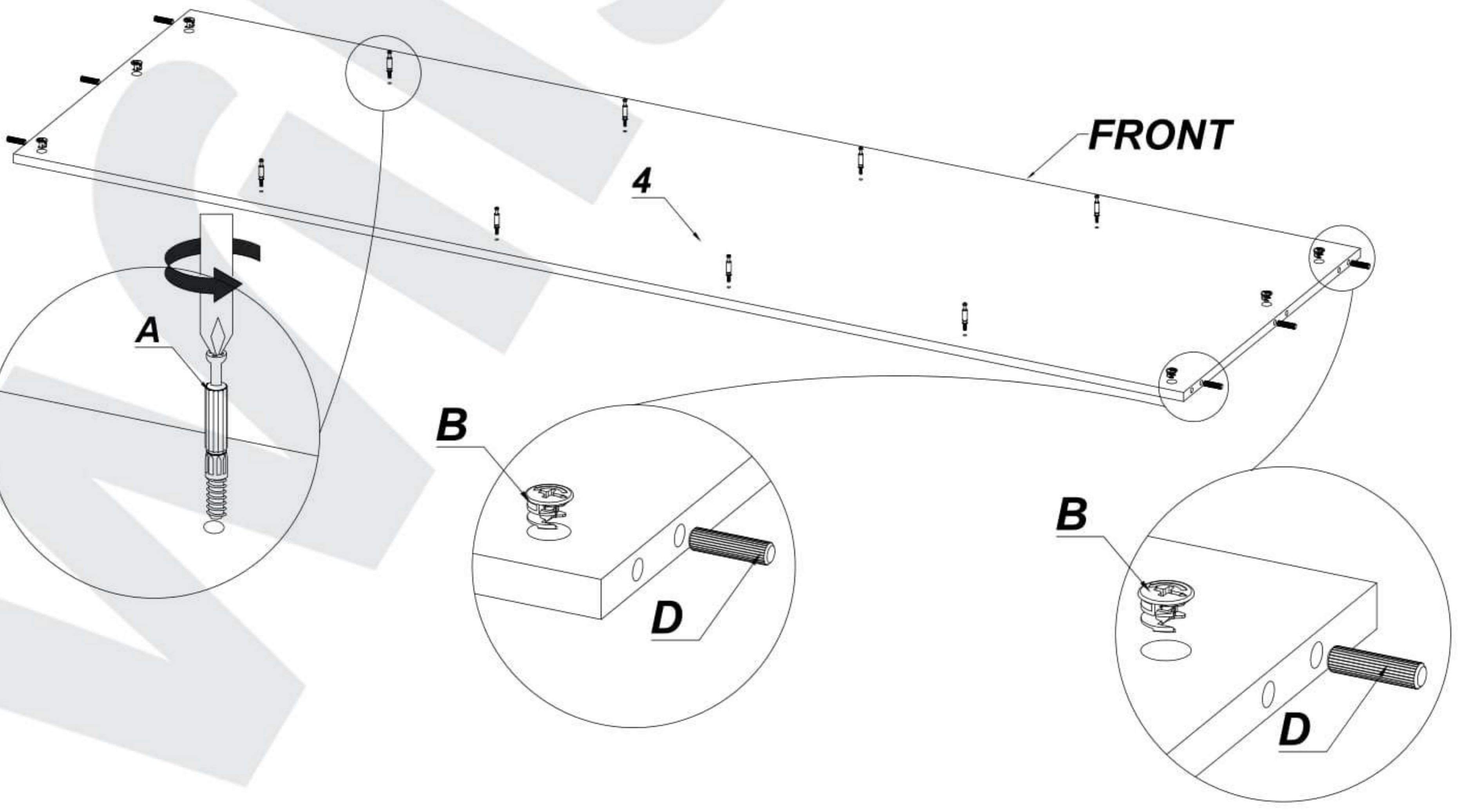
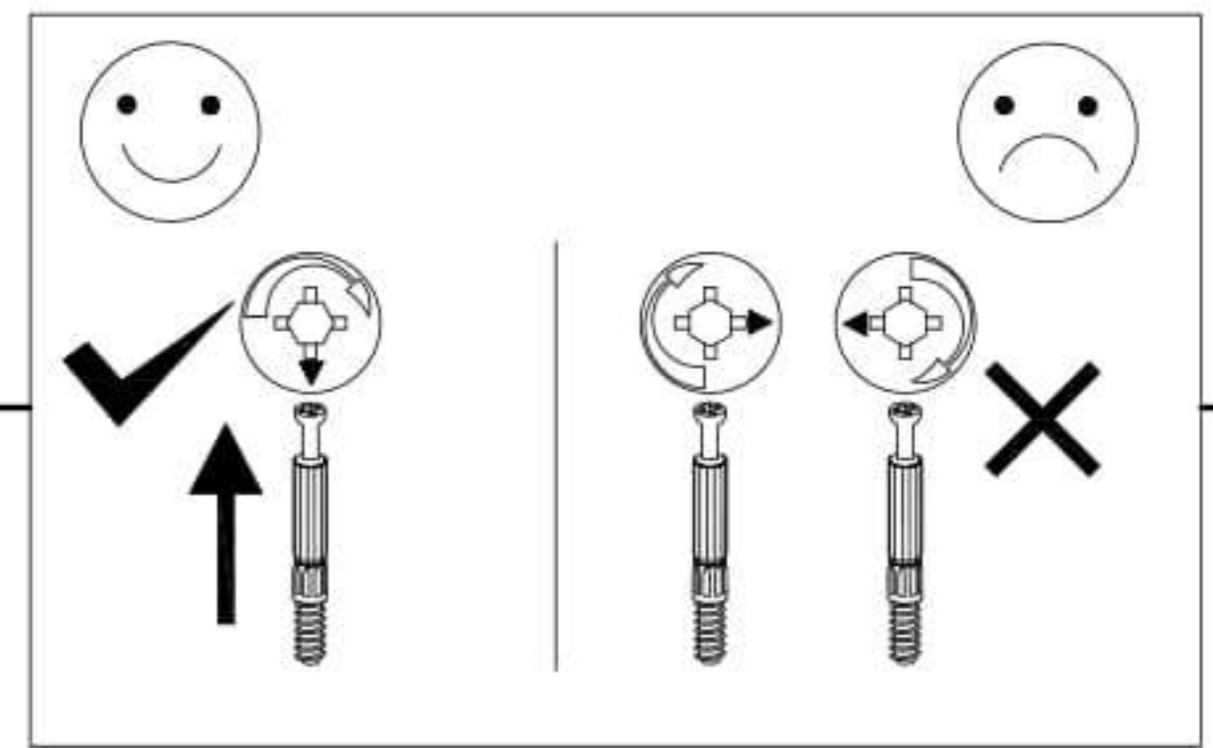
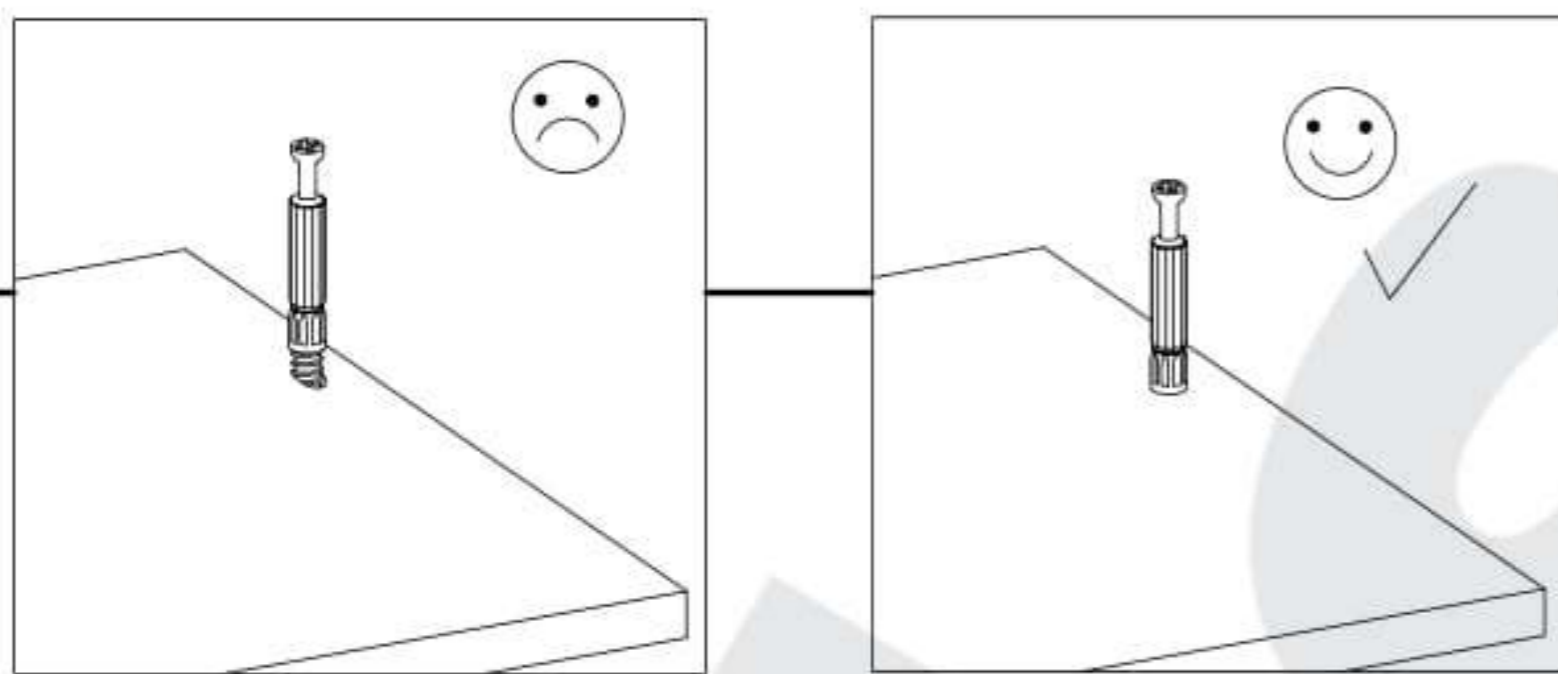



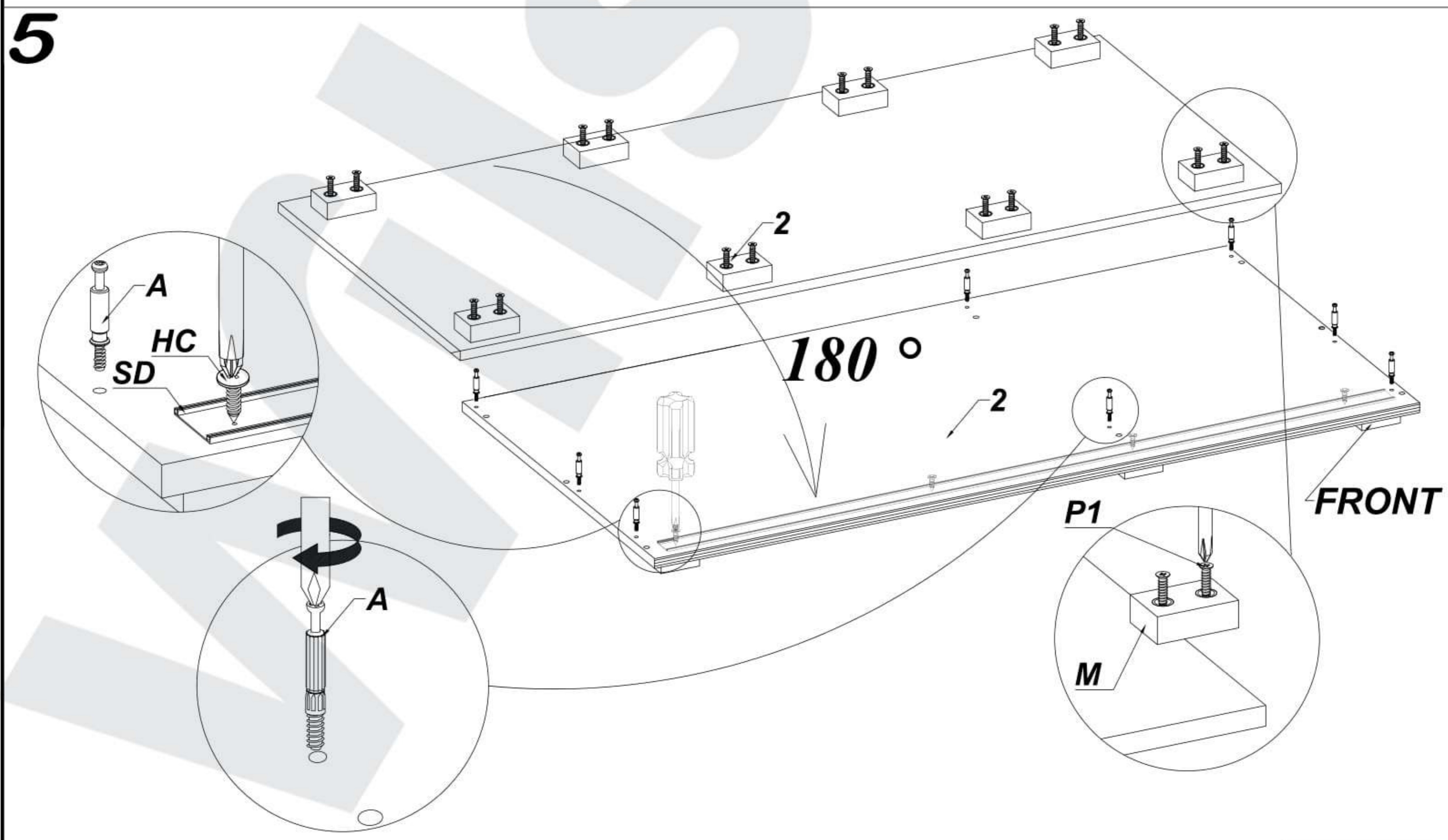
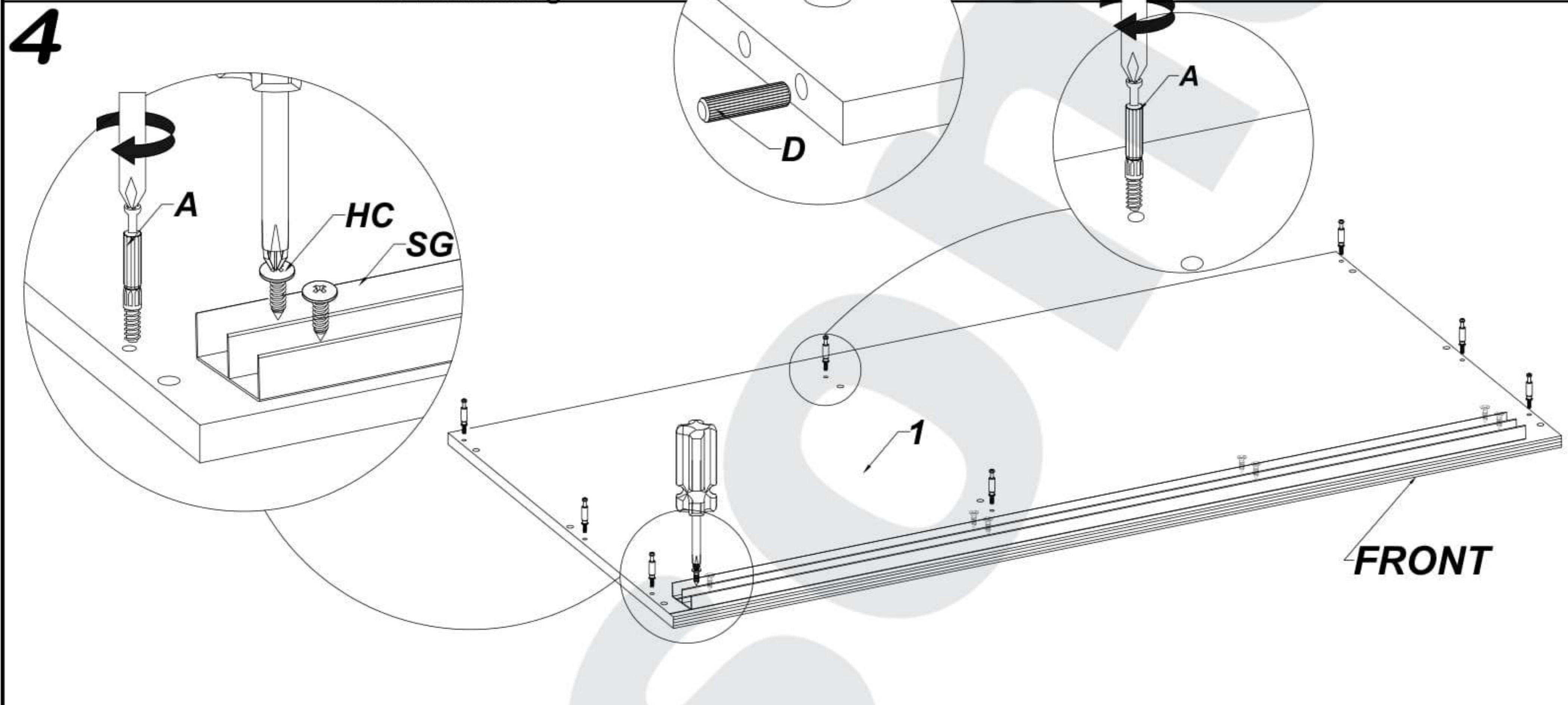
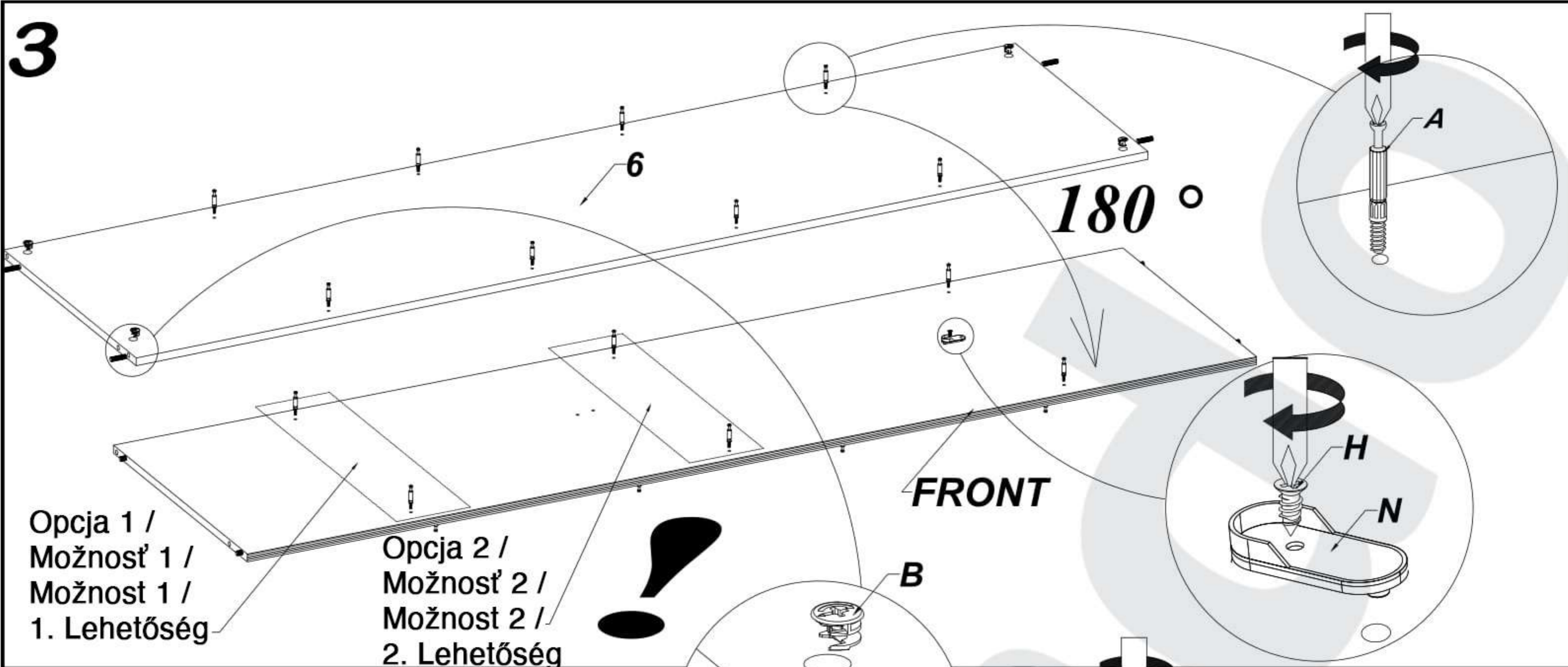



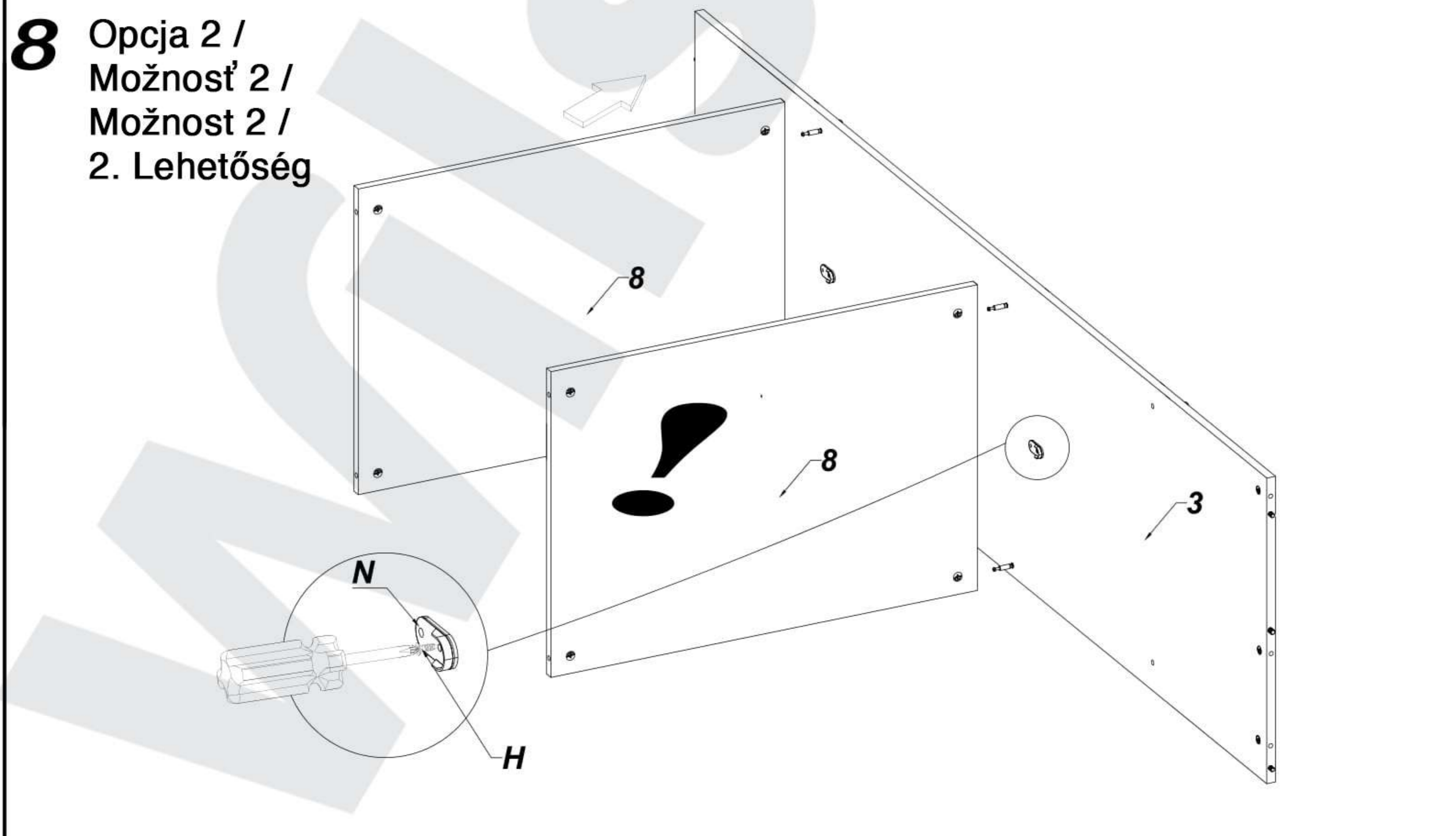
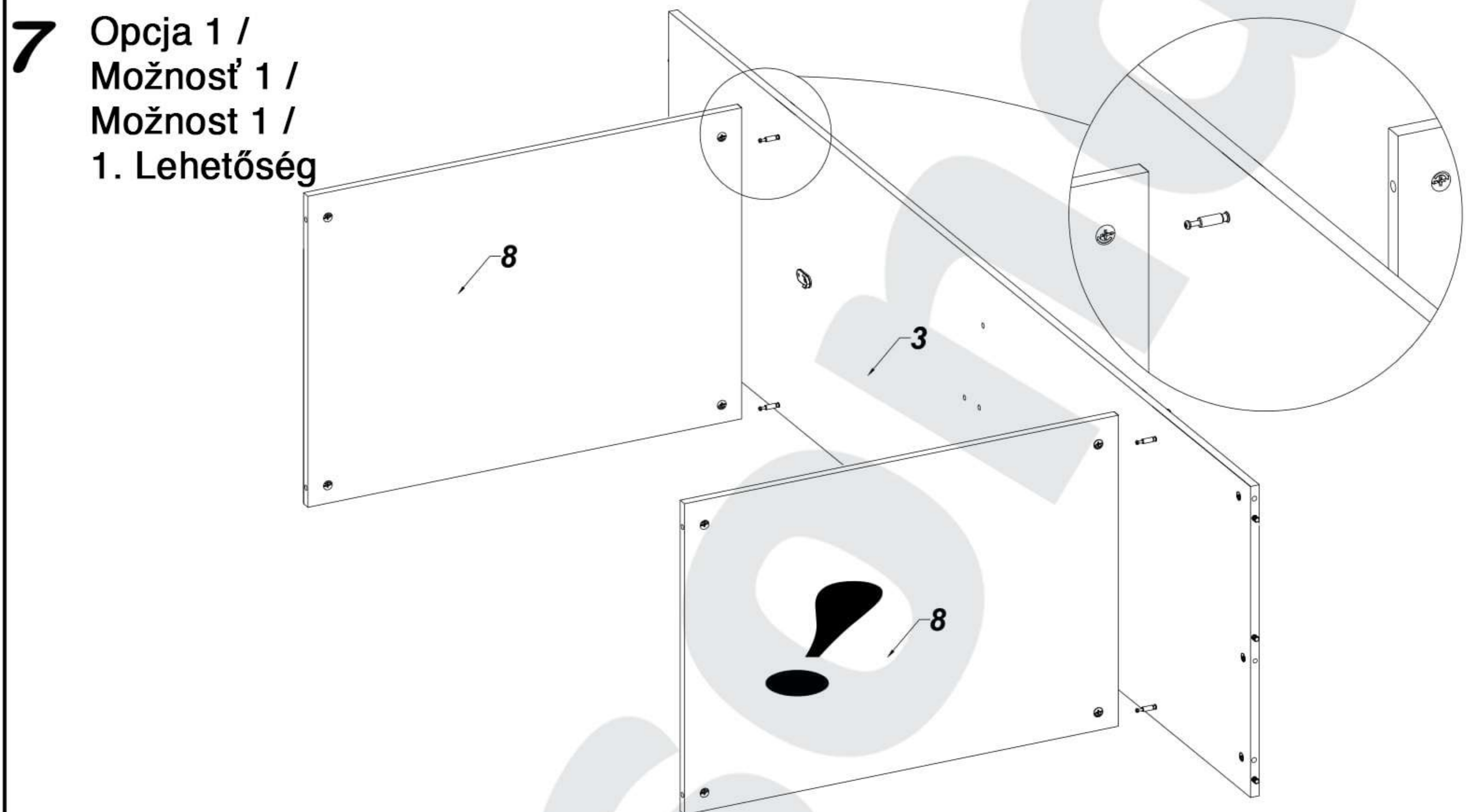
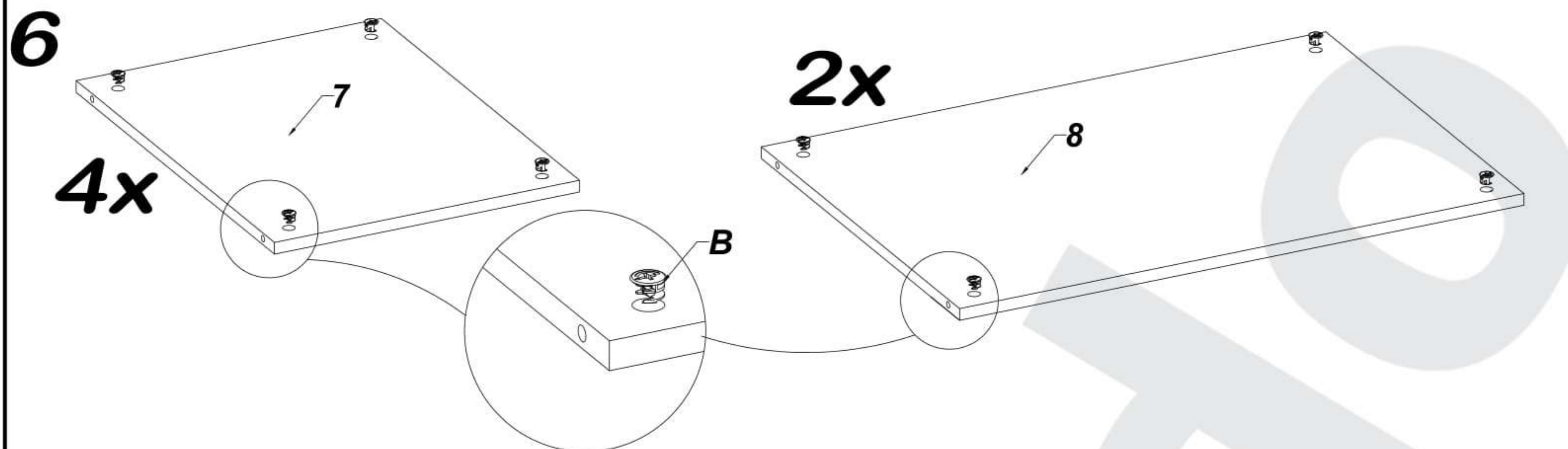



9

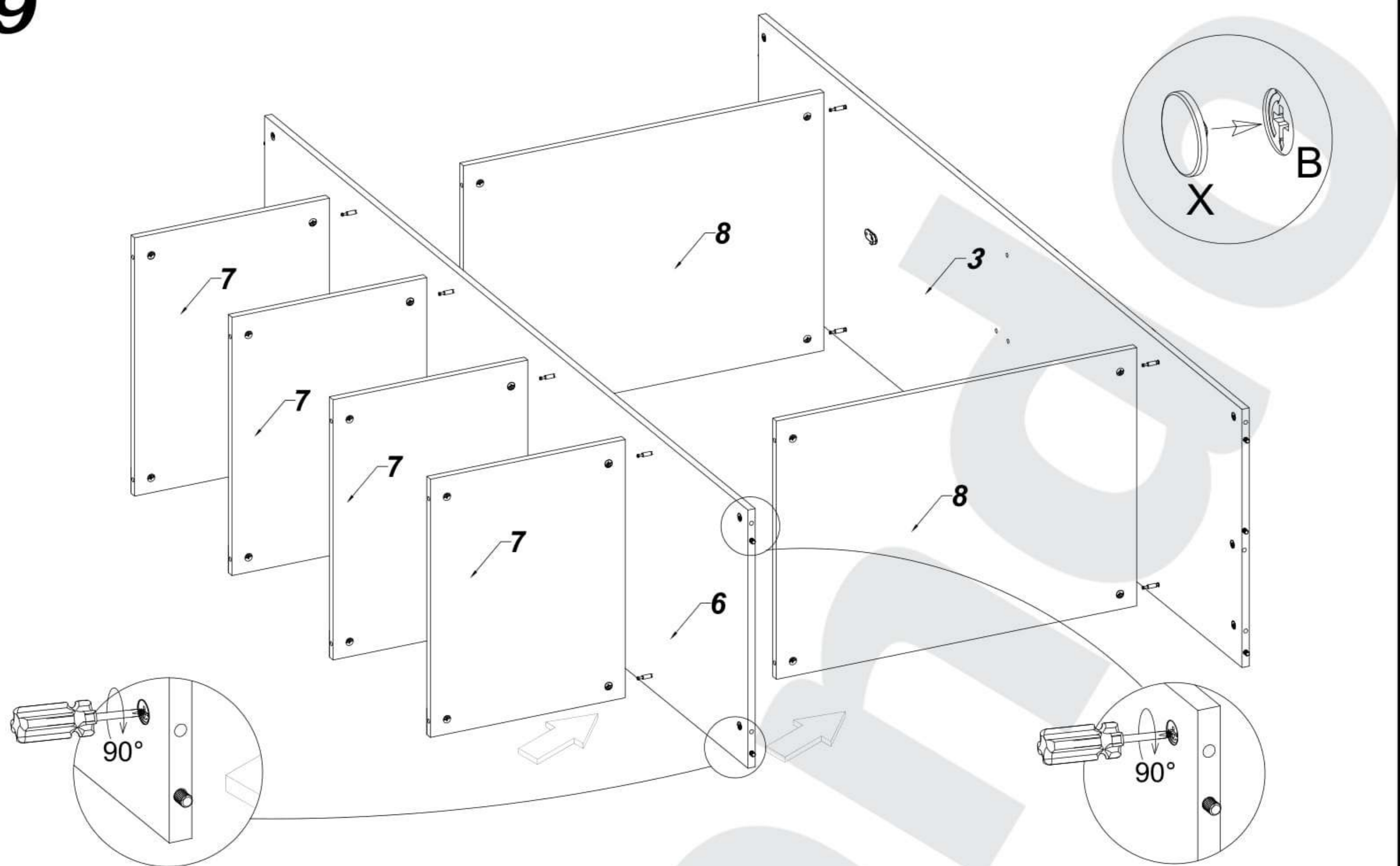

10

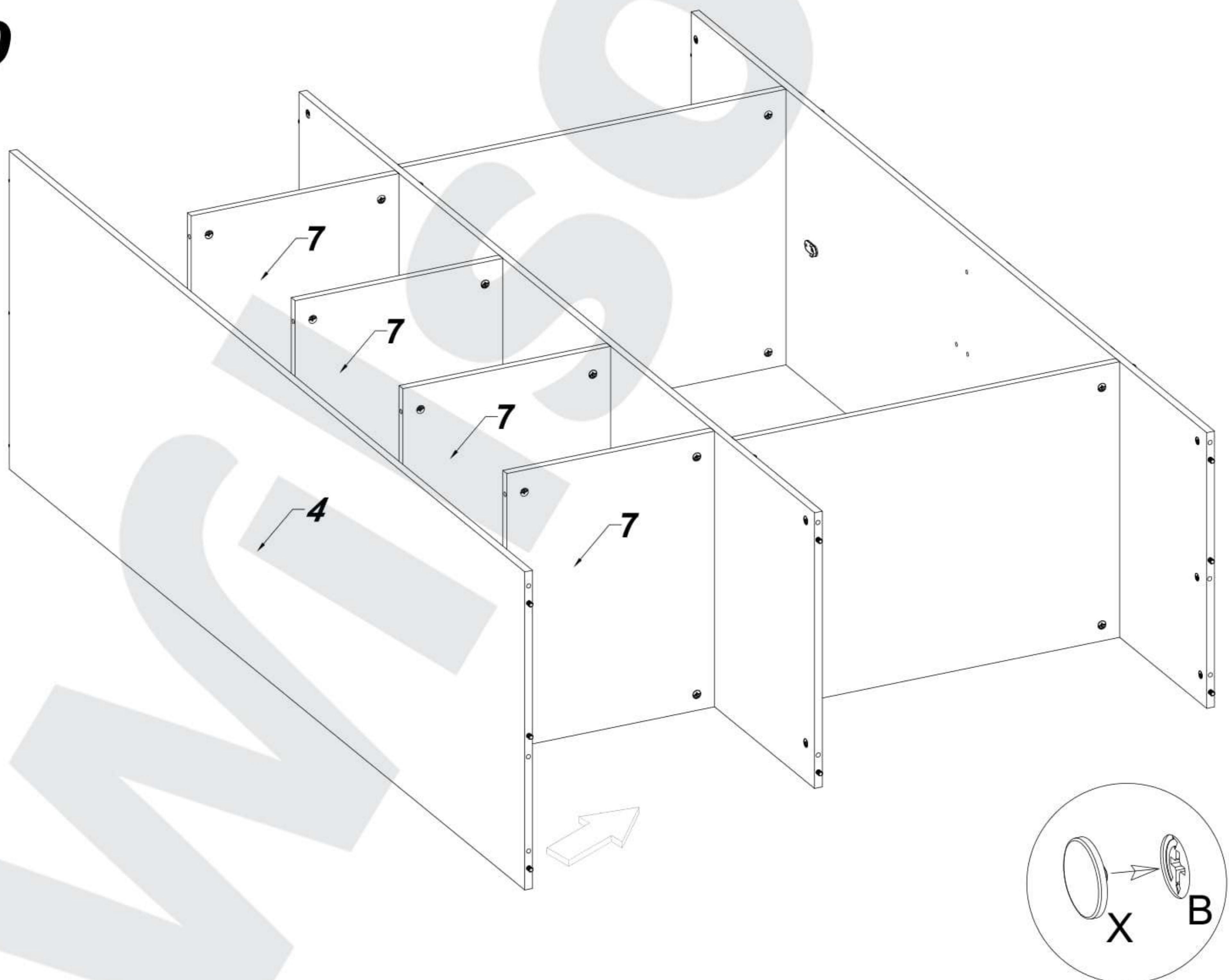







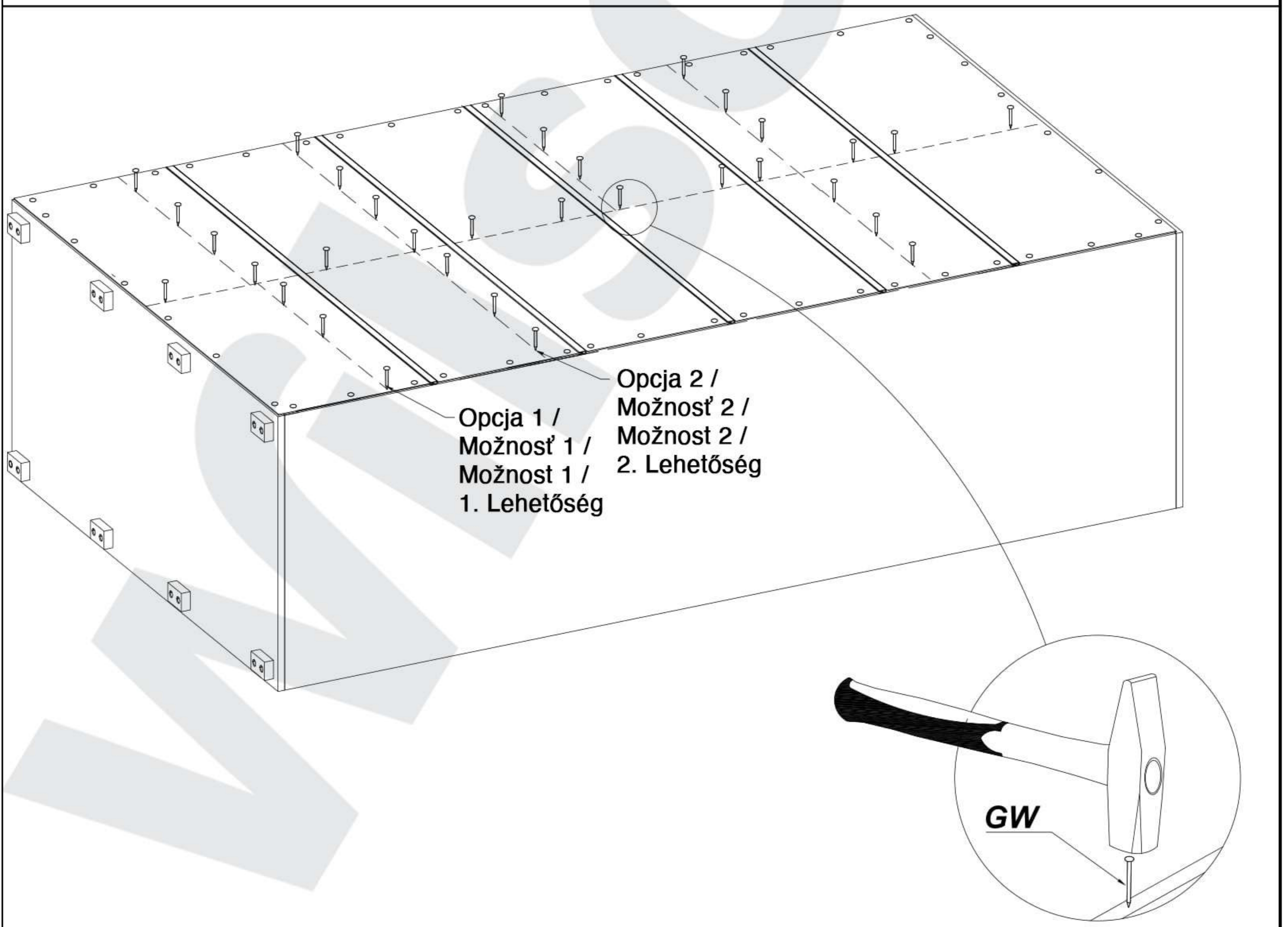
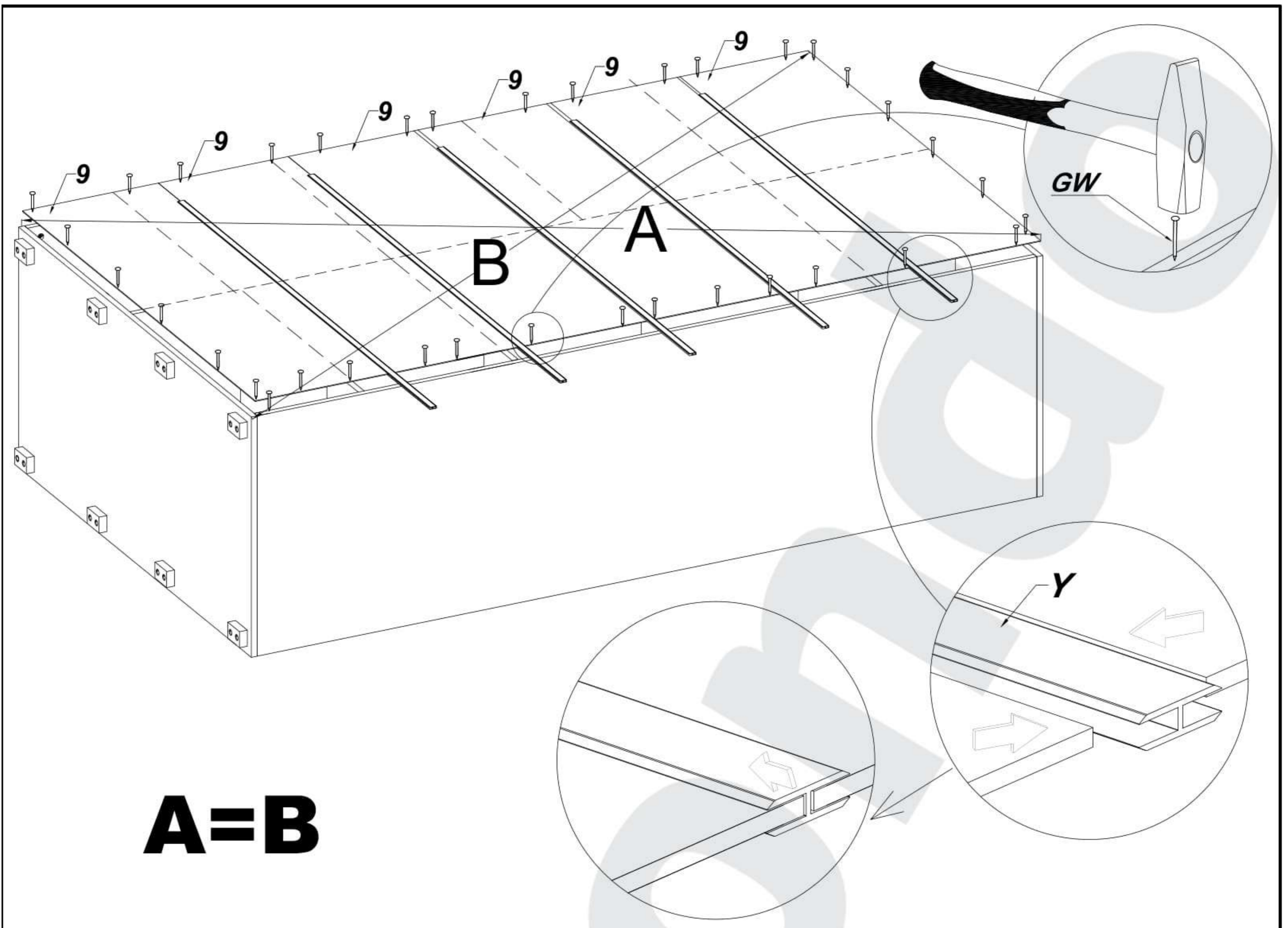



13

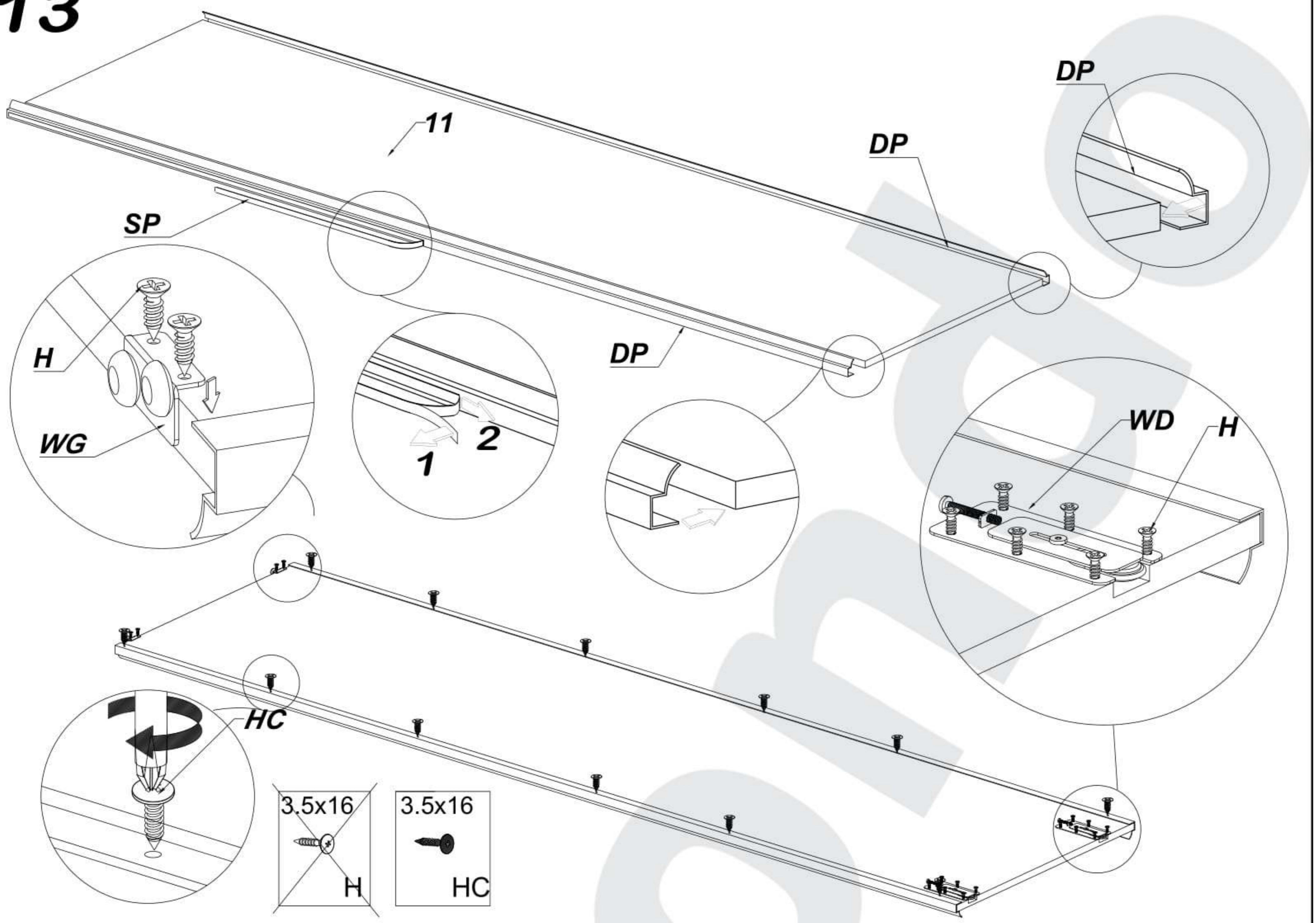

14

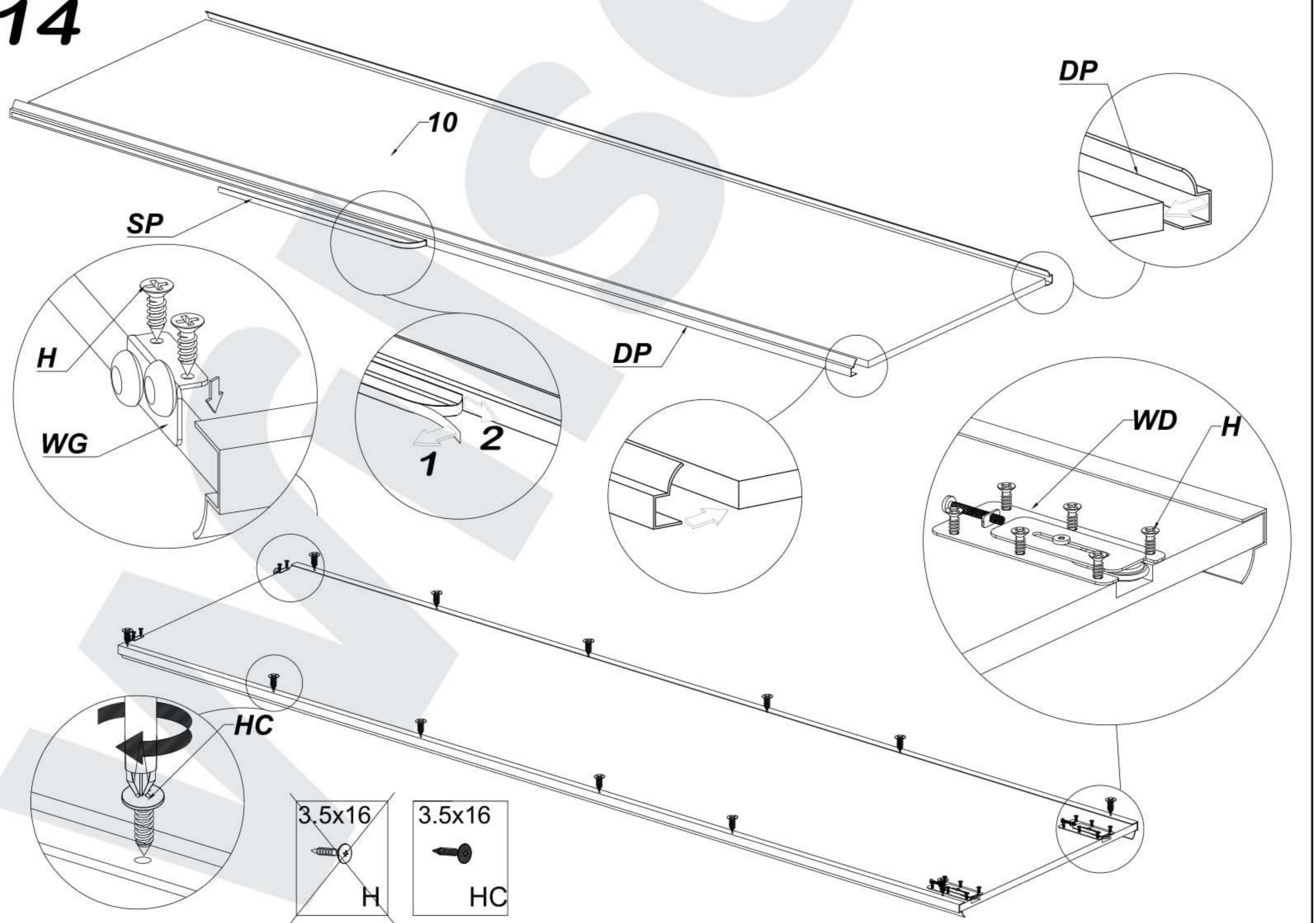



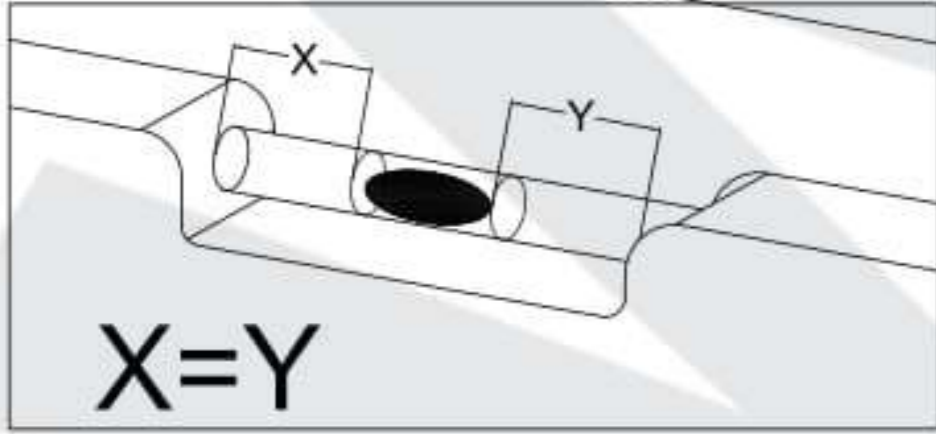
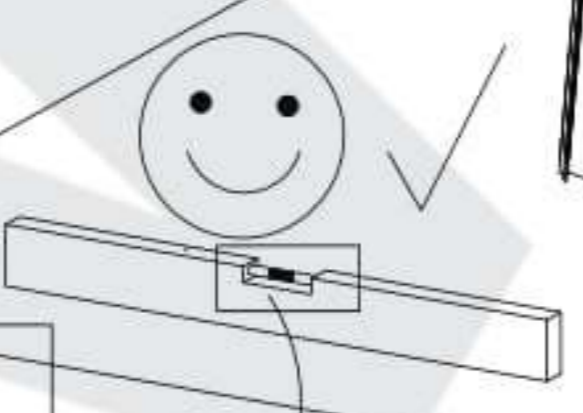
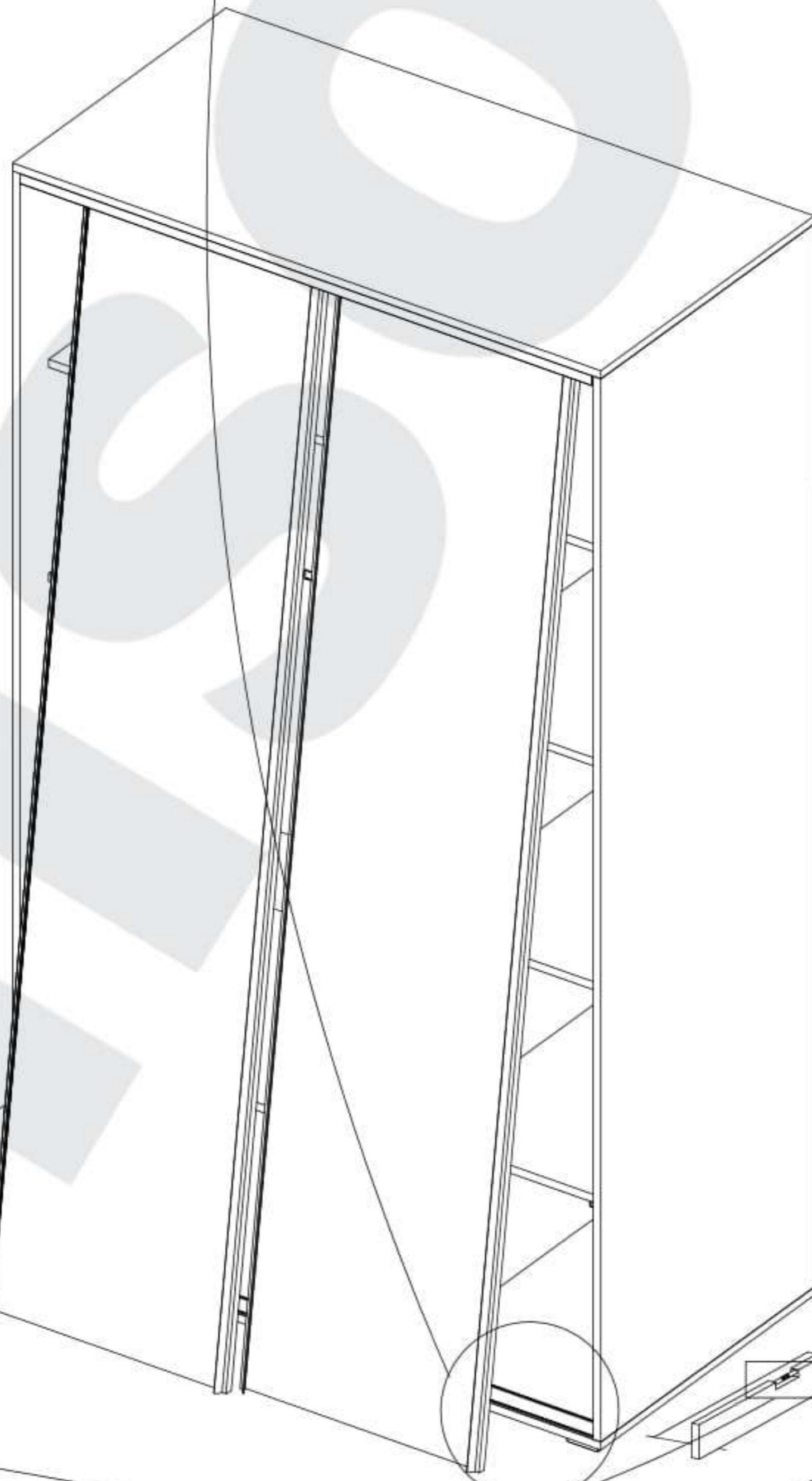

X=Y



## Opcja "A" / Možnosť "A" / Možnost "A" / "A" Lehetőség

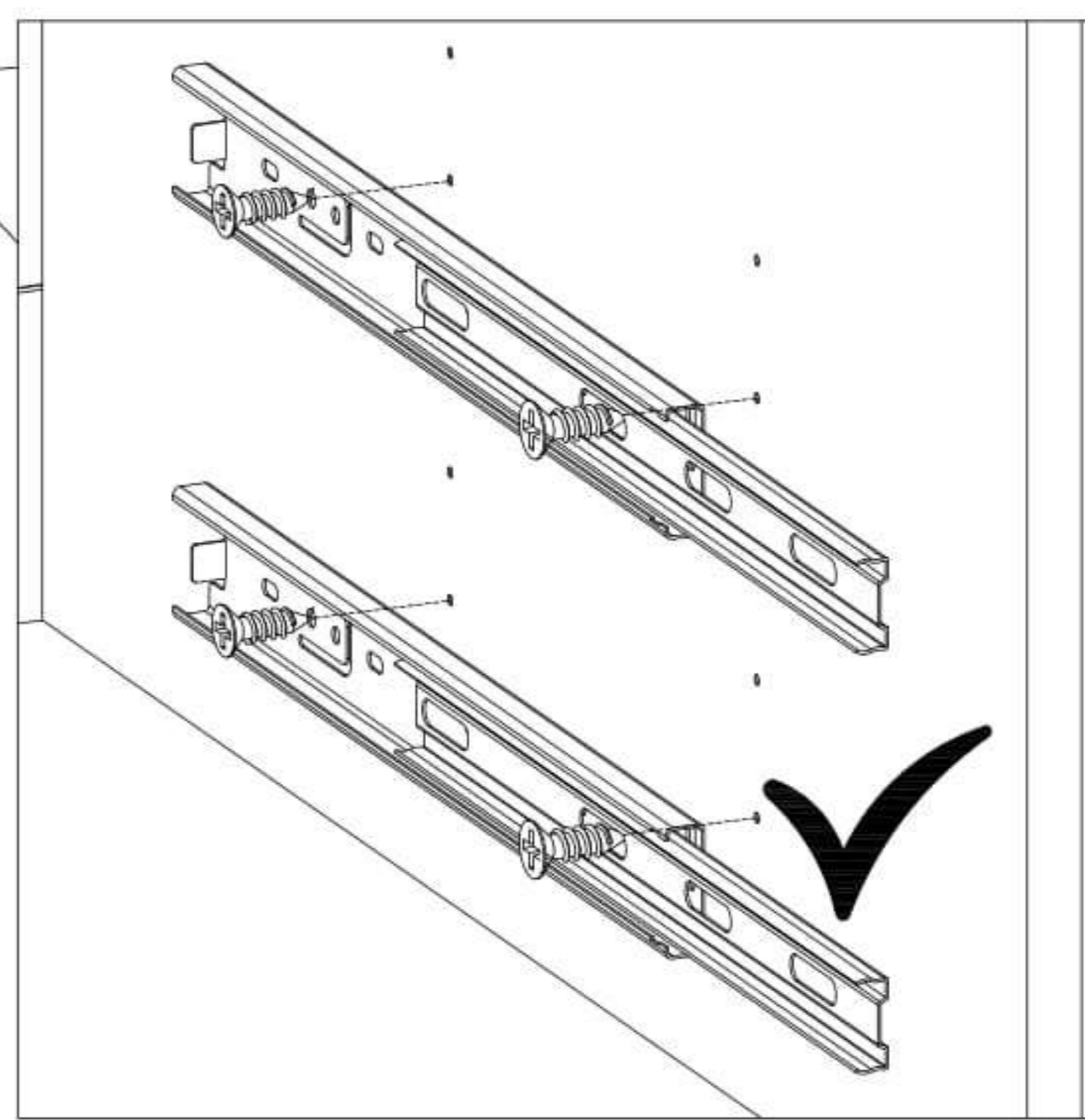
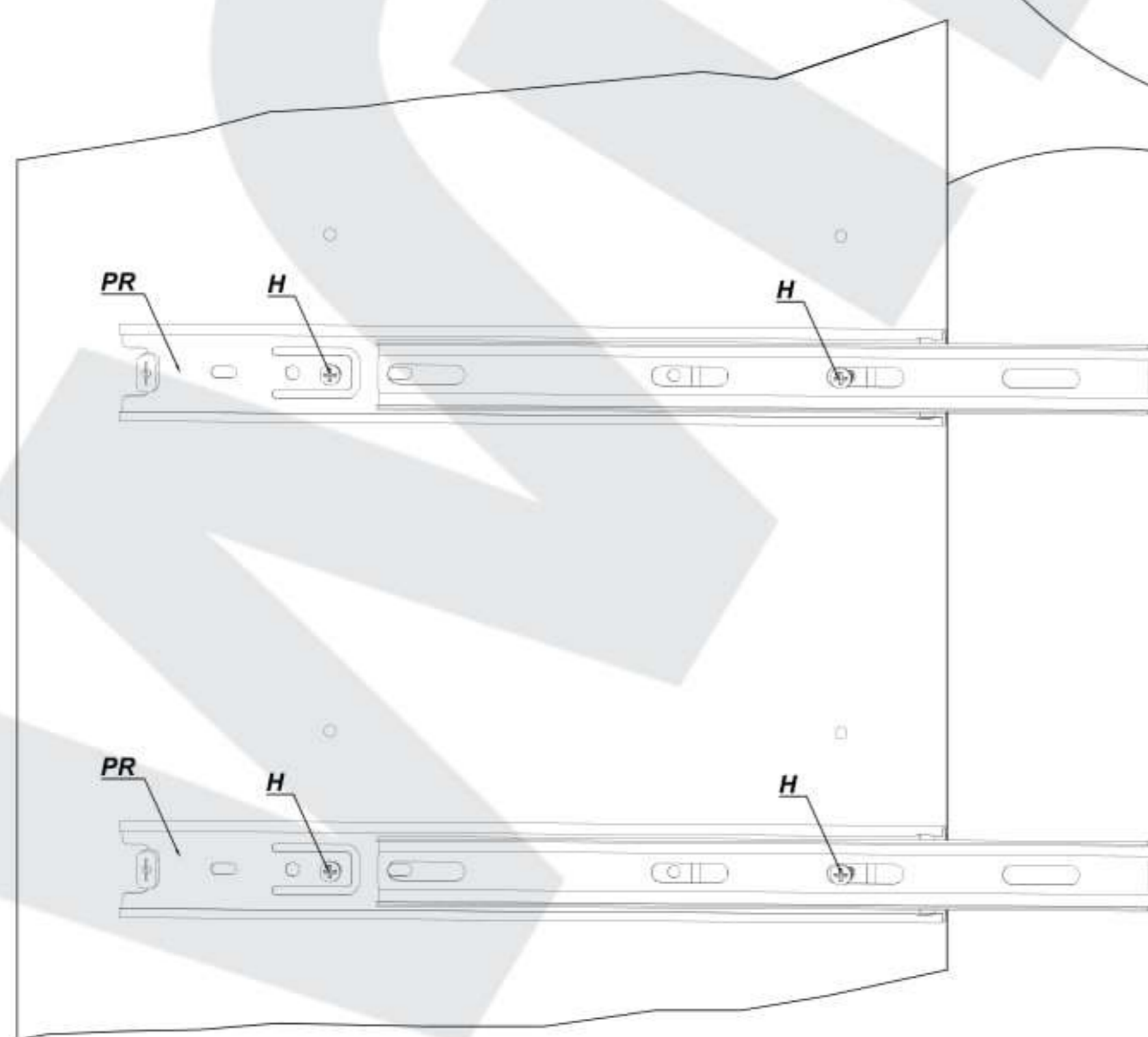
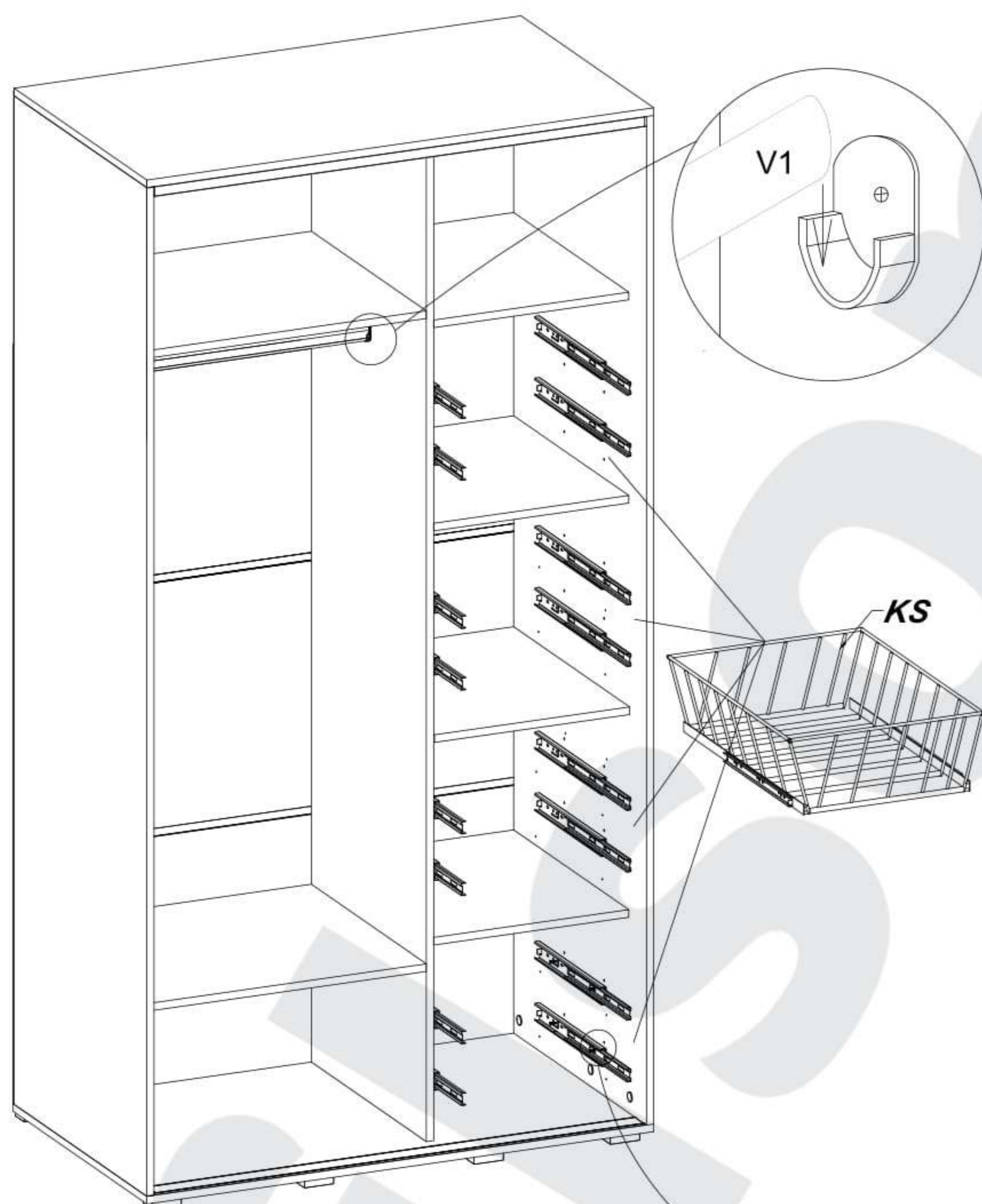
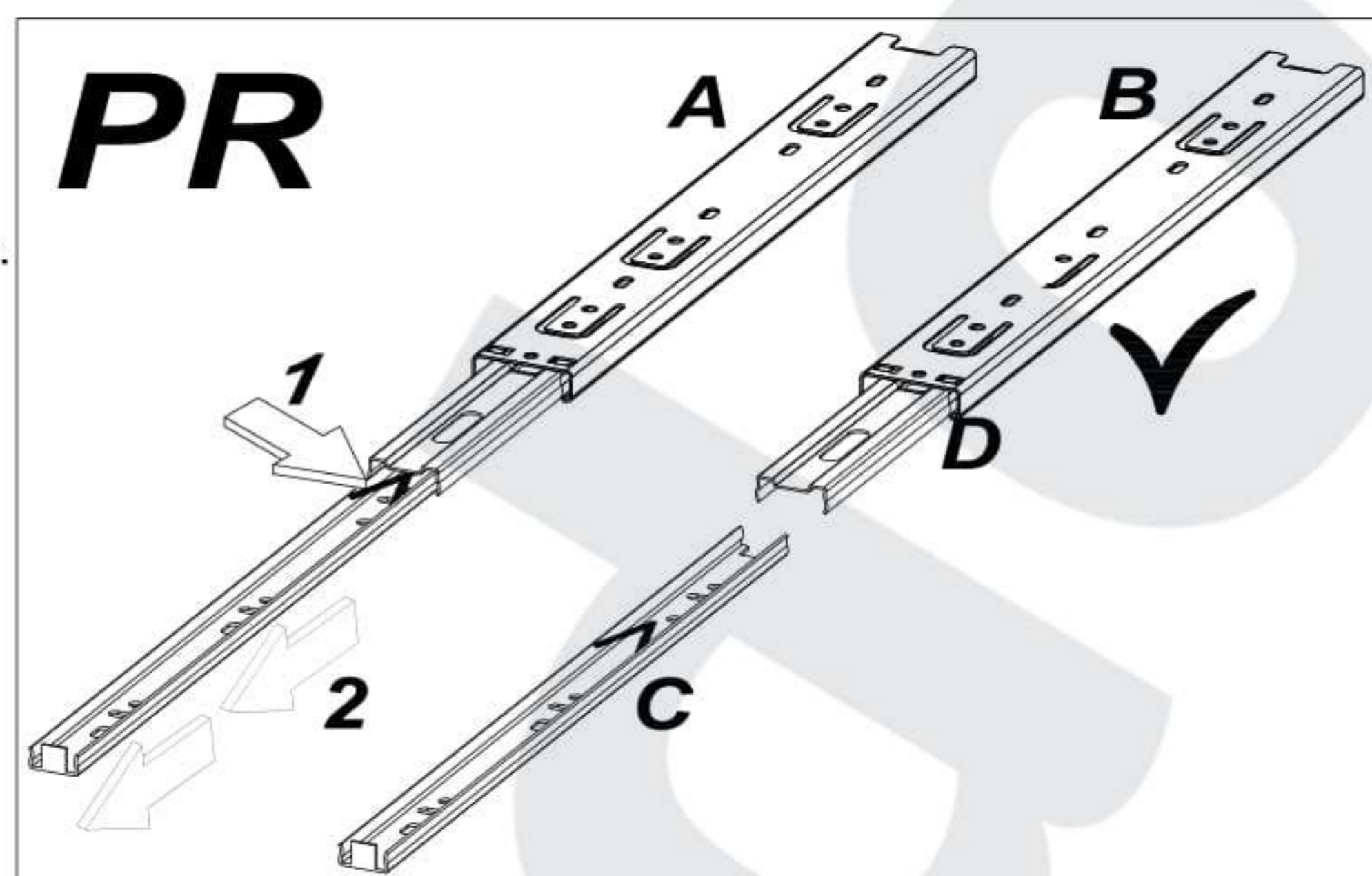

**PL:** Instrukcja montażu kosza - znajduje się w opakowaniu z koszem.  
**D:** Installationsanleitung für den Korb – im Paket mit dem Korb enthalten.  
**GB:** Basket installation instructions - included in the package with the basket.  
**F:** Instructions d'installation du panier - incluses dans l'emballage avec le panier.  
**NL:** Mandinstallatie-instructies - inbegrepen in het pakket met de mand.  
**SK:** Návod na montáž košíka - súčasťou balenia s košíkom.  
**CZ:** Návod na montáž koše - součástí balení s košem.  
**HU:** Szerelési útmutató a kosár beszereléséhez - a csomagolás részét képezi a kosárral együtt.  
**HR:** Upute za montažu košare - nalaze se u paketu s košarom.



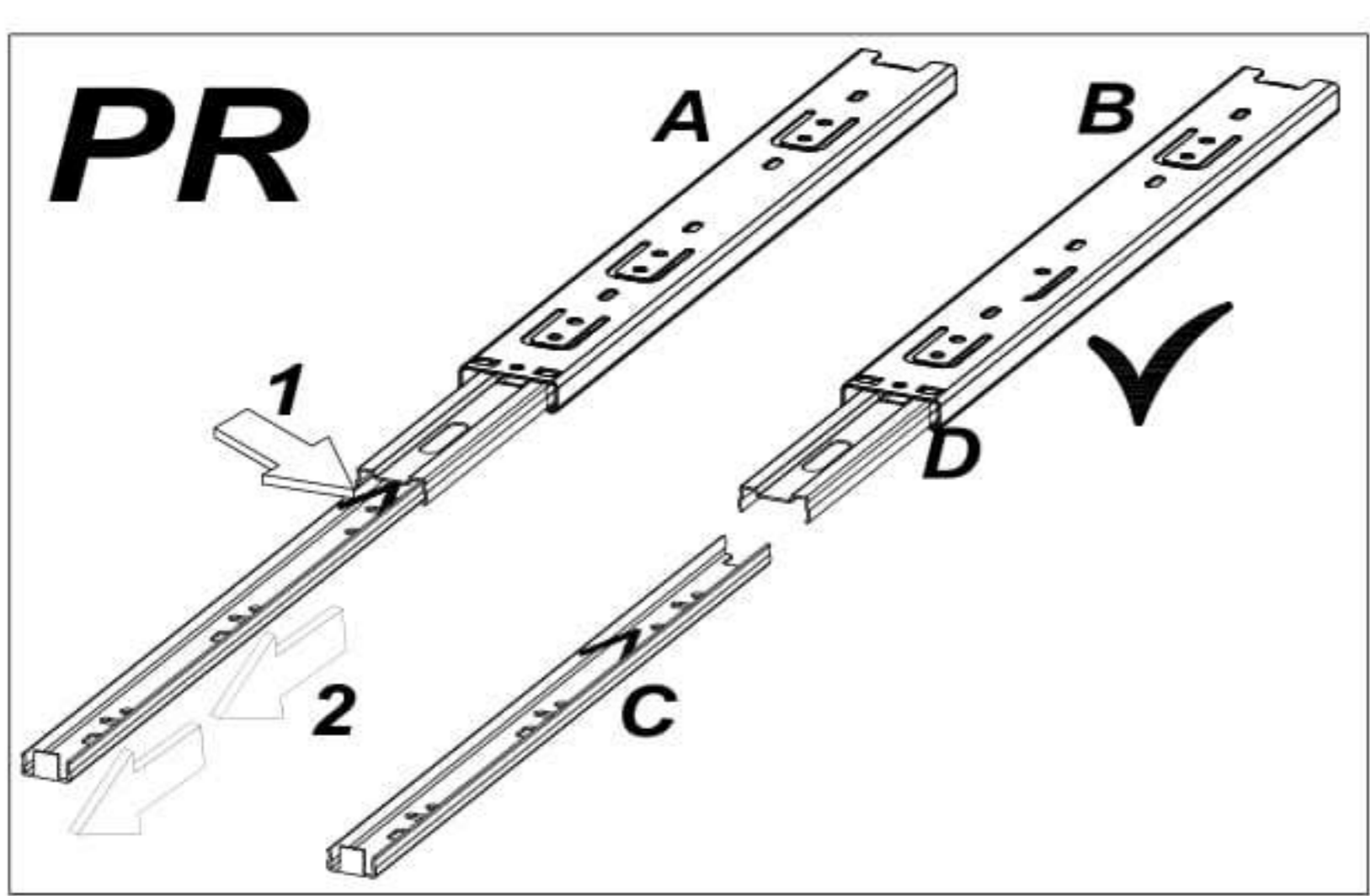

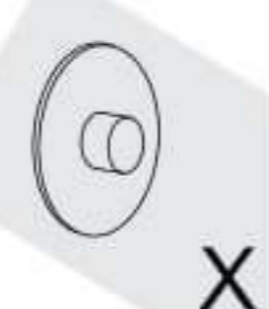

Opcja "B" /  
Možnosť "B" /  
Možnosť "B" /  
"B" Lehetőség

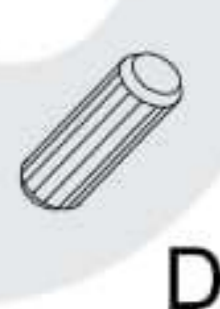
		3.5x16
PR		H
2		24
		
X	A	M
8	8	8
		
		D
		8

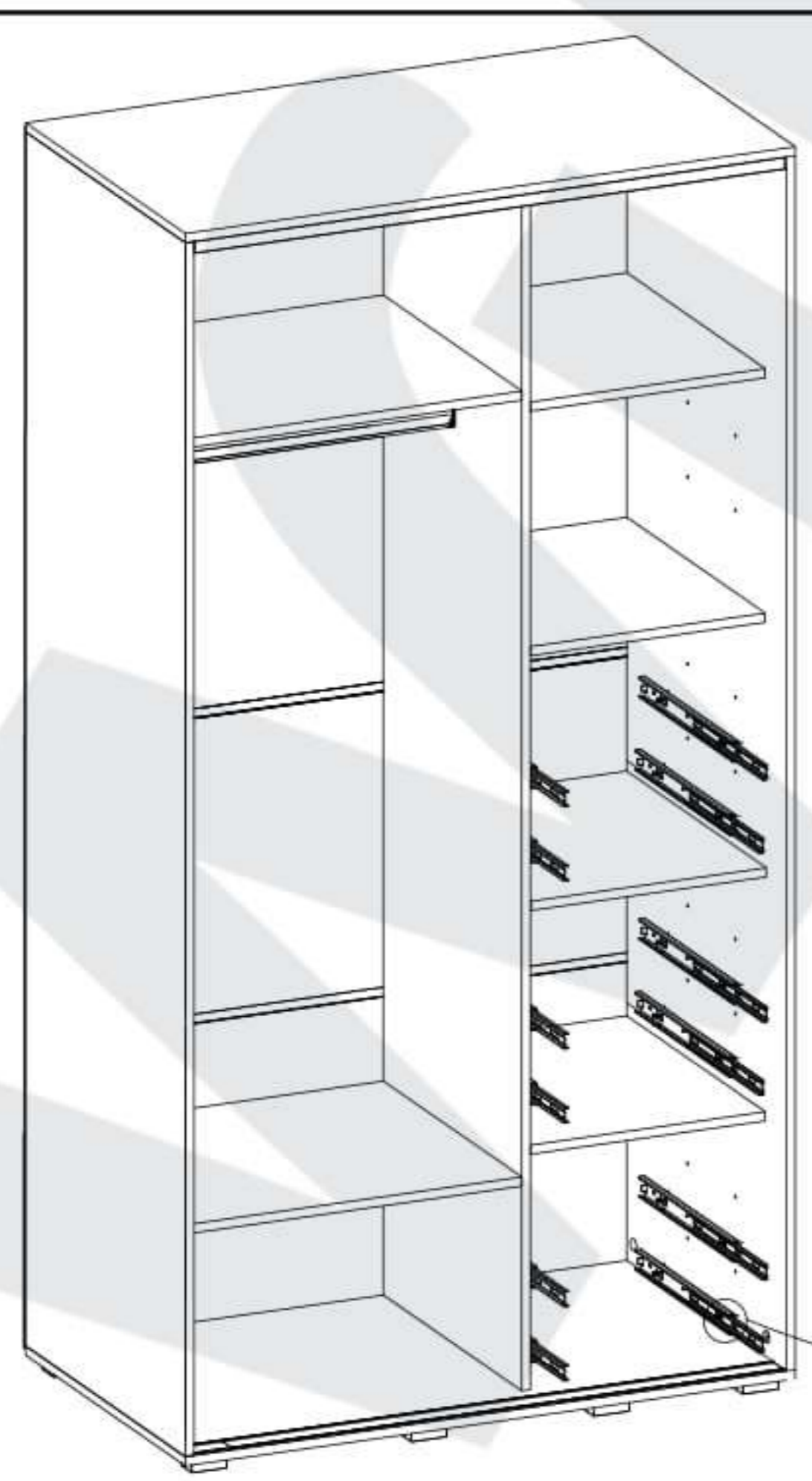
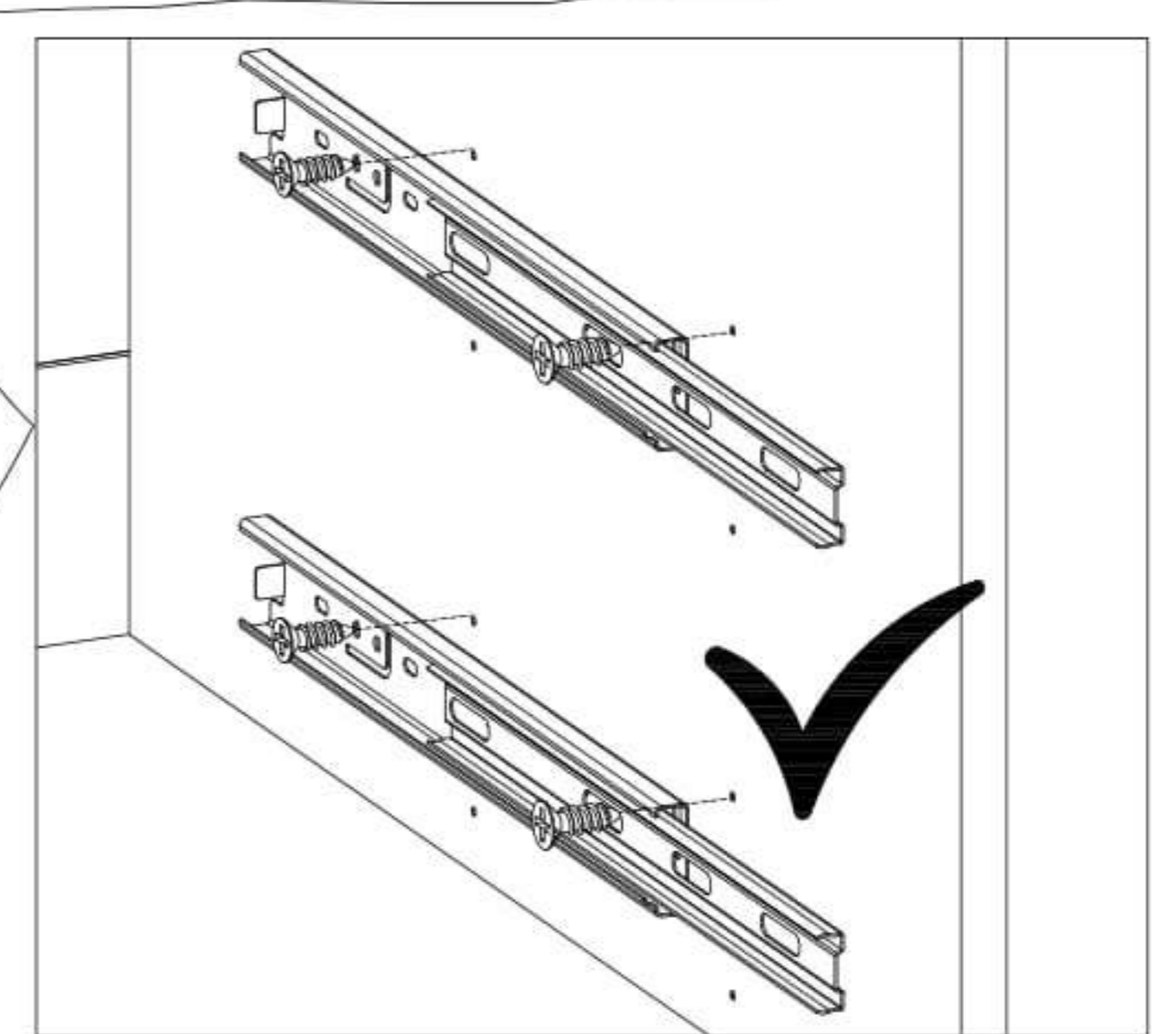
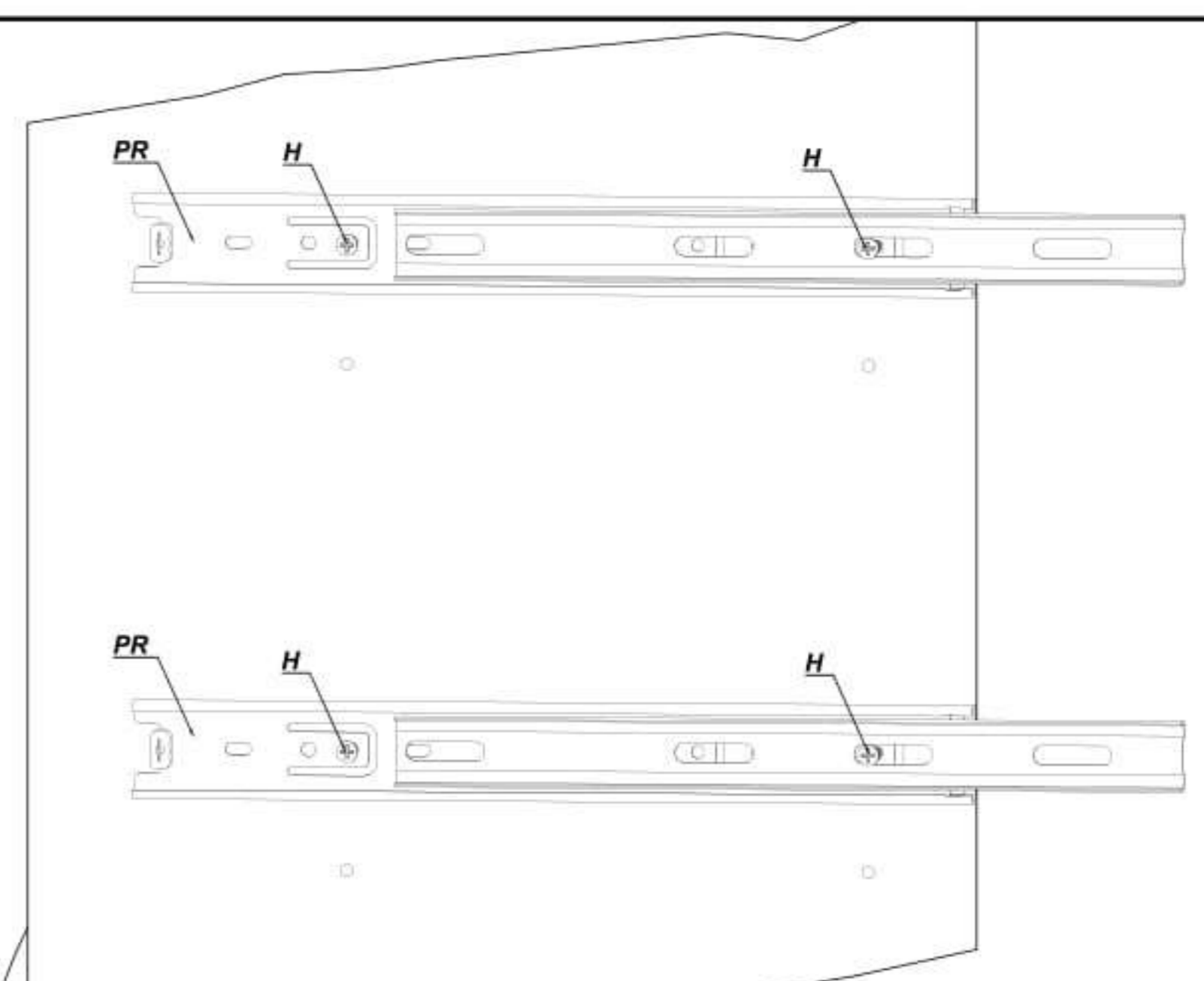
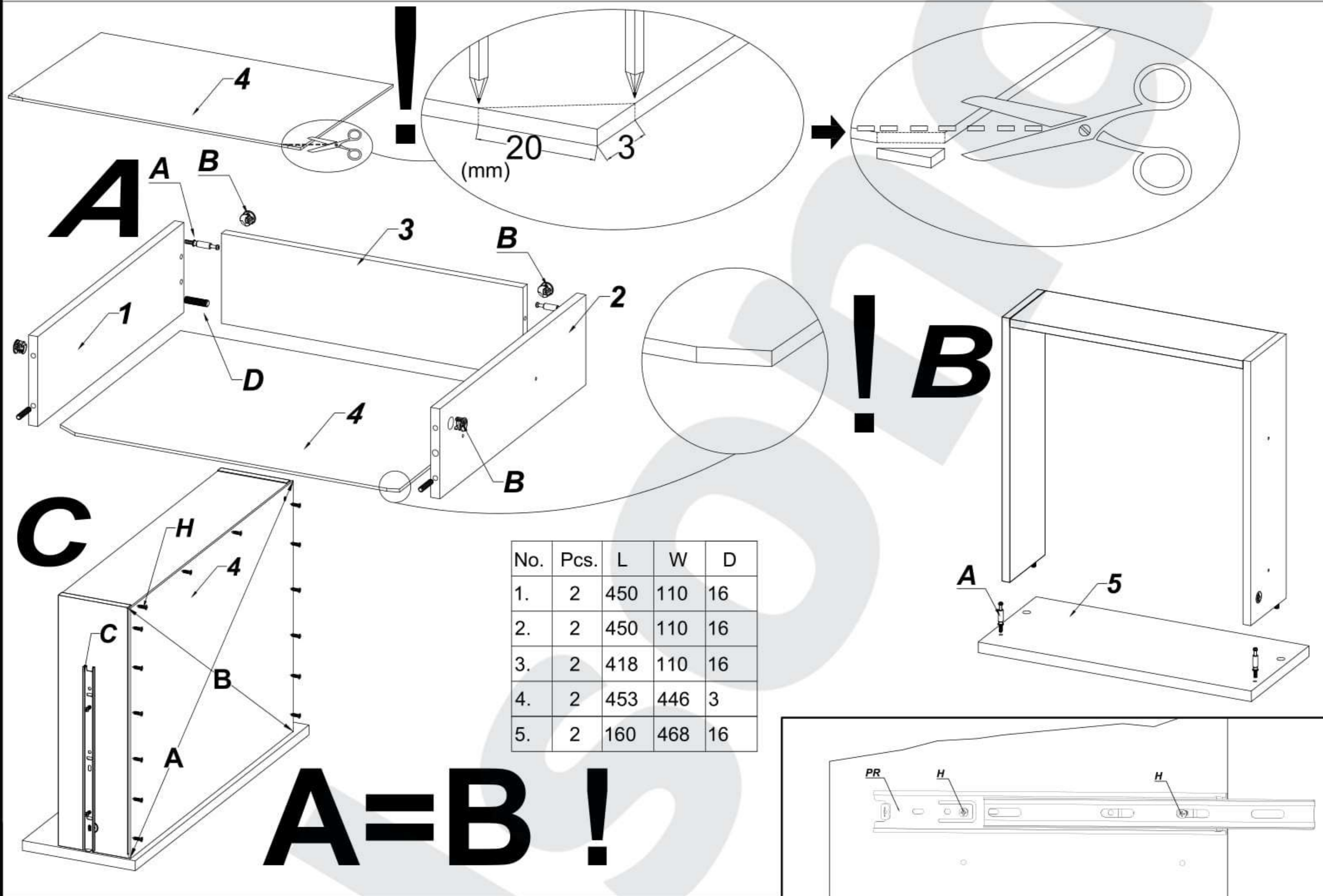



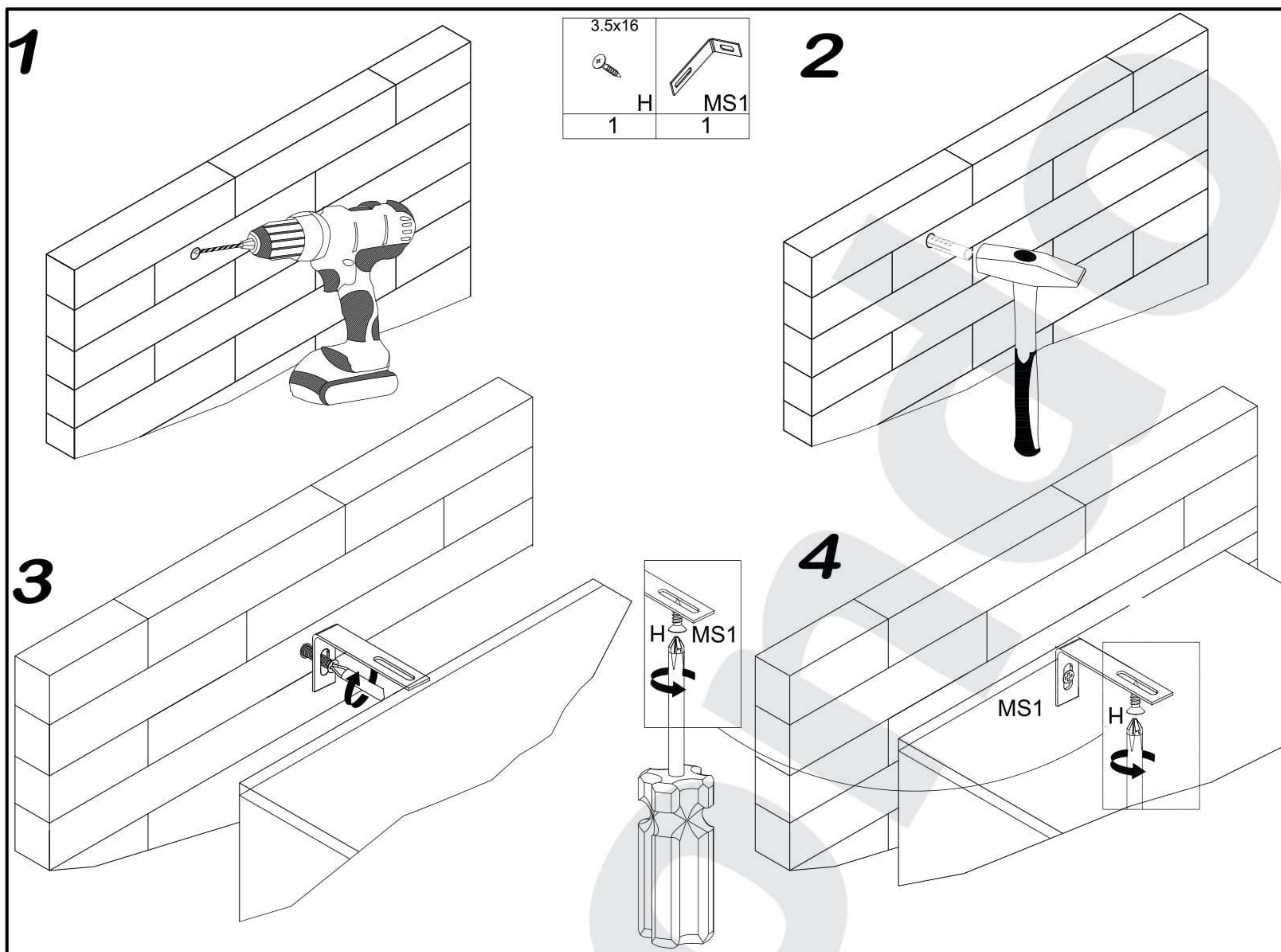

<b>PL</b>	<p>!!! Kołek montażowy należy dobrać do odpowiedniego rodzaju ściany - do zakupu w własnym zakresie !!!</p> <p>Przy montażu artykułu na ścianie należy zastosować odpowiednie do niej zamocowania. W razie wątpliwości prosimy zasięgnąć porady fachowca.</p> <p><b>Uwaga:</b> Mocowanie mebla do ściany mogą przeprowadzić wyłącznie wykwalifikowane osoby, z uwagi na zastosowanie odpowiednio dopasowanych kołków do rodzaju ściany.</p>
<b>D</b>	<p>!!! Der Befestigungsstift sollte für den entsprechenden Wandtyp ausgewählt werden – er muss selbst erworben werden !!!</p> <p>Für andere Wandaufbauten sind eventuell Spezialdübel und andere Schrauben notwendig. Ziehen Sie gegebenenfalls eine Fachkraft zurate.</p> <p><b>Achtung:</b> Die Befestigung des Möbelstückes an der Wand muss von einer fachkundigen Person vorgenommen werden, da für die Montage an die Wand angepasste Dübel erforderlich sind.</p>
<b>GB</b>	<p>!!! The mounting pin should be selected for the appropriate type of wall - to be purchased on your own !!!</p> <p>Special dowels and other screws may be necessary for other wall constructions. If necessary, please consult a qualified professional.</p> <p><b>Attention:</b> A qualified professional is required when mounting furniture to the wall since dowels corresponding to the wall are required for this.</p>
<b>F</b>	<p>!!! La goupille de fixation doit être sélectionnée pour le type de mur approprié - elle doit être achetée séparément !!!</p> <p>Pour les autres constructions de murs, il faut éventuellement des chevilles spéciales et d'autres vis. Faites-vous conseiller par un spécialiste.</p> <p><b>Attention:</b> La fixation du meuble contre le mur doit être effectuée par une personne compétente car, pour le montage mural, il faut utiliser des chevilles adaptées.</p>
<b>NL</b>	<p>!!! De bevestigingspin moet worden geselecteerd voor het juiste type muur - deze moet afzonderlijk worden aangeschaft !!!</p> <p>Voor andere muurconstructies zijn eventueel speciale pluggen en andere schroeven noodzakelijk. Consulteer eventueel een vakman</p> <p><b>Opgelet:</b> een vakkundige persoon dient het meubelstuk aan de muur te bevestigen; voor de montage aan de muur zijn immers aangepaste pluggen vereist.</p>
<b>SK</b>	<p>!!! Montážny materiál do steny nie je súčasťou balenia, musí byť vybraný pre príslušný typ steny, a je potrebné ho zakúpiť samostatne !!!</p> <p>Ohľadom skrutiek alebo hmoždiniek, ktoré sa majú použiť pre daný typ steny, sa obráťte na špecializovanú predajňu alebo odborníka.</p> <p><b>Pozor:</b> Upevnenie nábytku na stenu musí vykonať odborník, nakoľko sú pre montáž na stenu potrebné vhodné hmoždinky.</p>
<b>CZ</b>	<p>!!! Montážní materiál do stěny není součástí balení, musí být vybrán pro příslušný typ stěny, a je třeba jej zakoupit samostatně !!!</p> <p>Ohledně šroubů nebo hmoždinek, které se mají použít pro daný typ stěny, se obraťte na specializovanou prodejnu nebo odborníka.</p> <p><b>Pozor:</b> Upevnění nábytku na zeď musí provést odborník, jelikož jsou pro montáž na zeď zapotřebí vhodné hmoždinky.</p>
<b>HU</b>	<p>!!! A falhoz való rögzítéshez szükséges csavarok és tiplik nem részei a csomagolásnak. Különböző faltípusokhoz más és más típusú csavarok és dübelek szükségesek, ezért külön kell megvásárolni. !!!</p> <p>A faltípushoz megfelelő csavarok vagy dübelek kiválasztásában kérjük, hogy kérje szakértő segítségét.</p> <p><b>Figyelem!</b> A bútorok falhoz való rögzítését szakember végezze! A bútorok falhoz való rögzítéséhez ugyanis a megfelelő típusú tipliket kell használni.</p>
<b>HR</b>	<p>!!! Zatim za pričvršćivanje treba odabrati za odgovarajuću vrstu zida - treba ga kupiti zasebno !!!</p> <p>Kada montirate proizvod na zid, koristite odgovarajuće pričvršne elemente. Ako ste u nedoumici, obratite se stručnjaku.</p> <p><b>Napomena:</b> Pričvršćivanje namještaja na zid smiju izvoditi samo kvalificirane osobe, zbog upotrebe pravilno usklađenih tipli s vrstom zida.</p>