

DERIVA

PL: Instrukcja montażu - łóżko
D: Aufbauanleitung - bett
GB: Assembly instruction - bed
FR: Instructions de montage - lit
SK: Návod na montáž - posteľ
CZ: Návod k montáži - postel
HU: Szerelési útmutató - ágy
HR: Upute za montažu - krevet

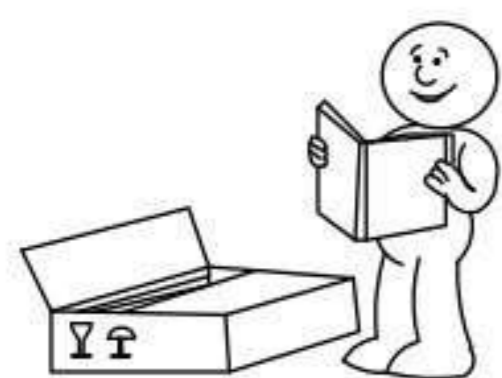

13 mm
10 mm

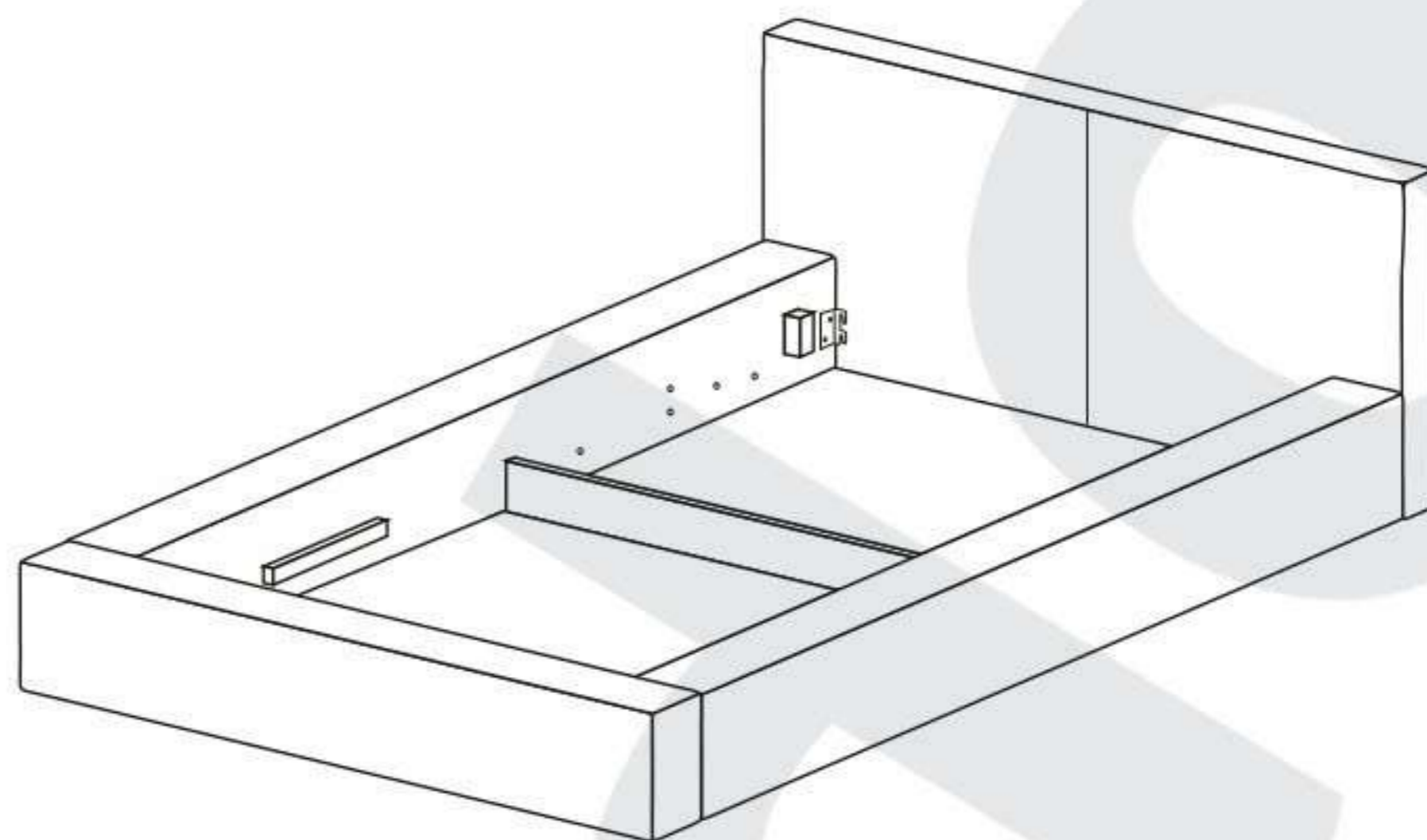
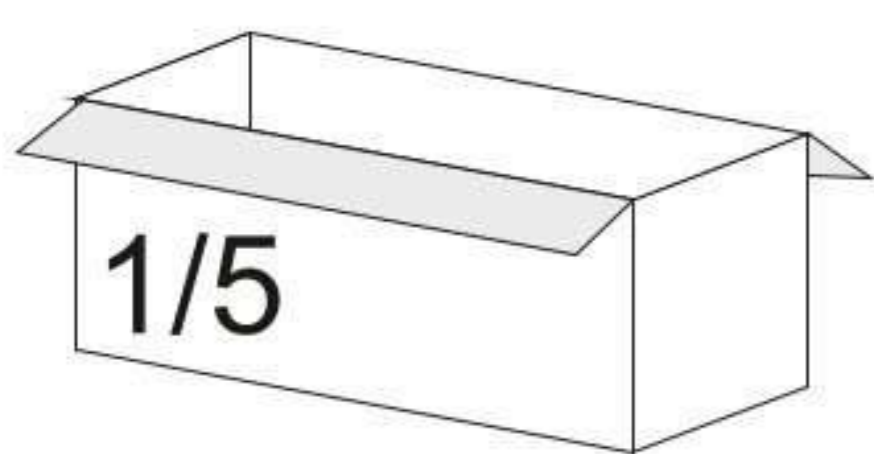
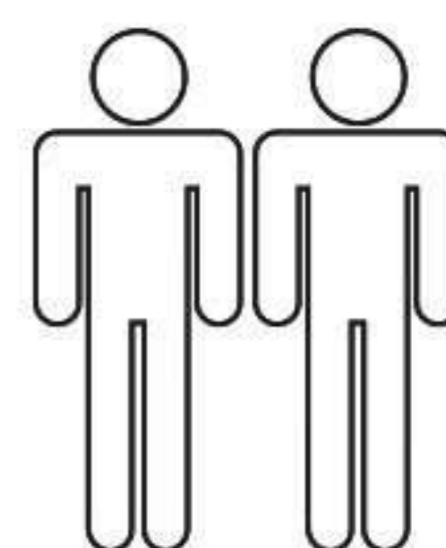

1/5

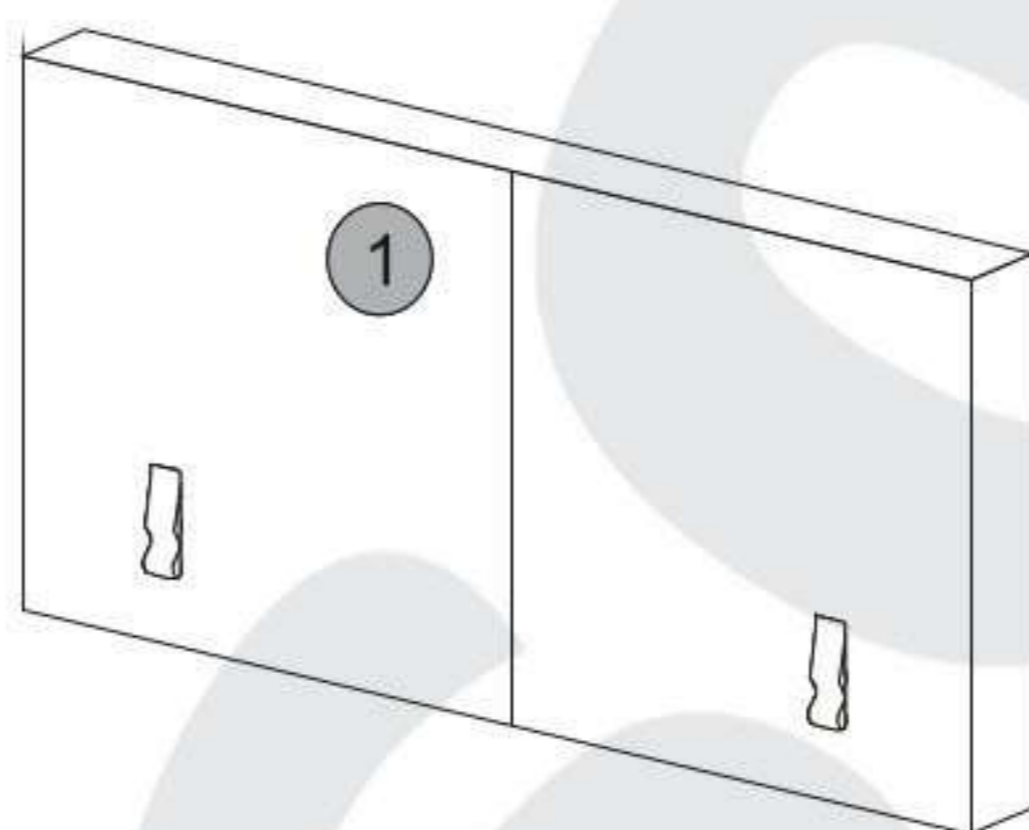

1

x1

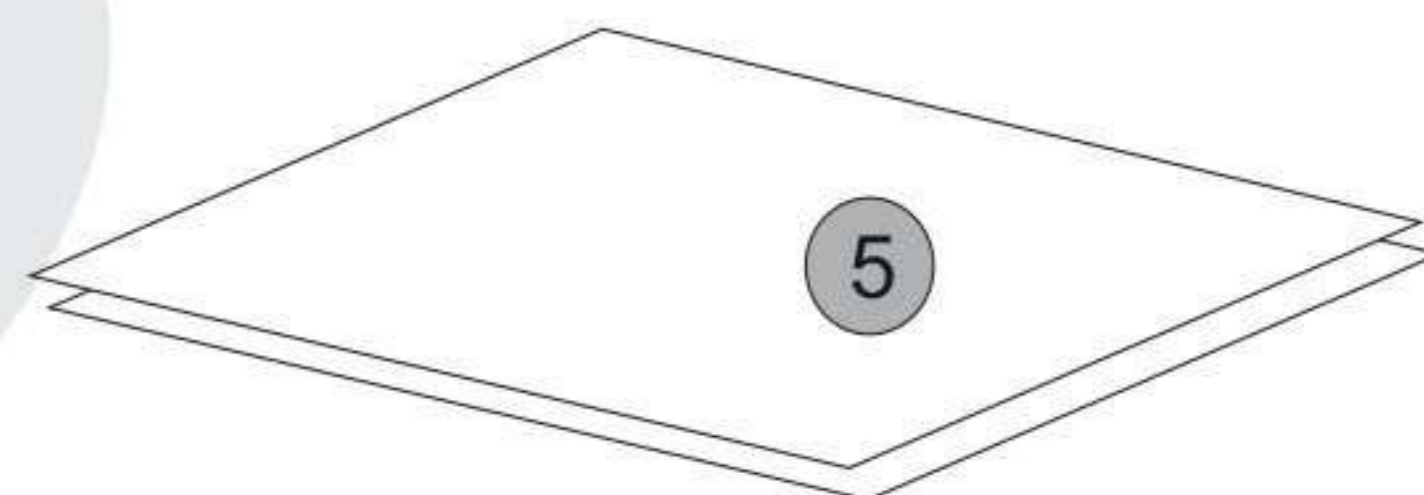

5

x2

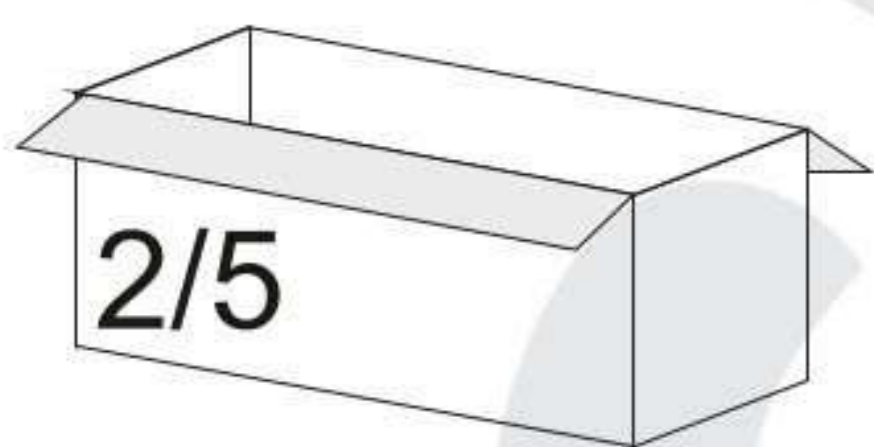

2/5

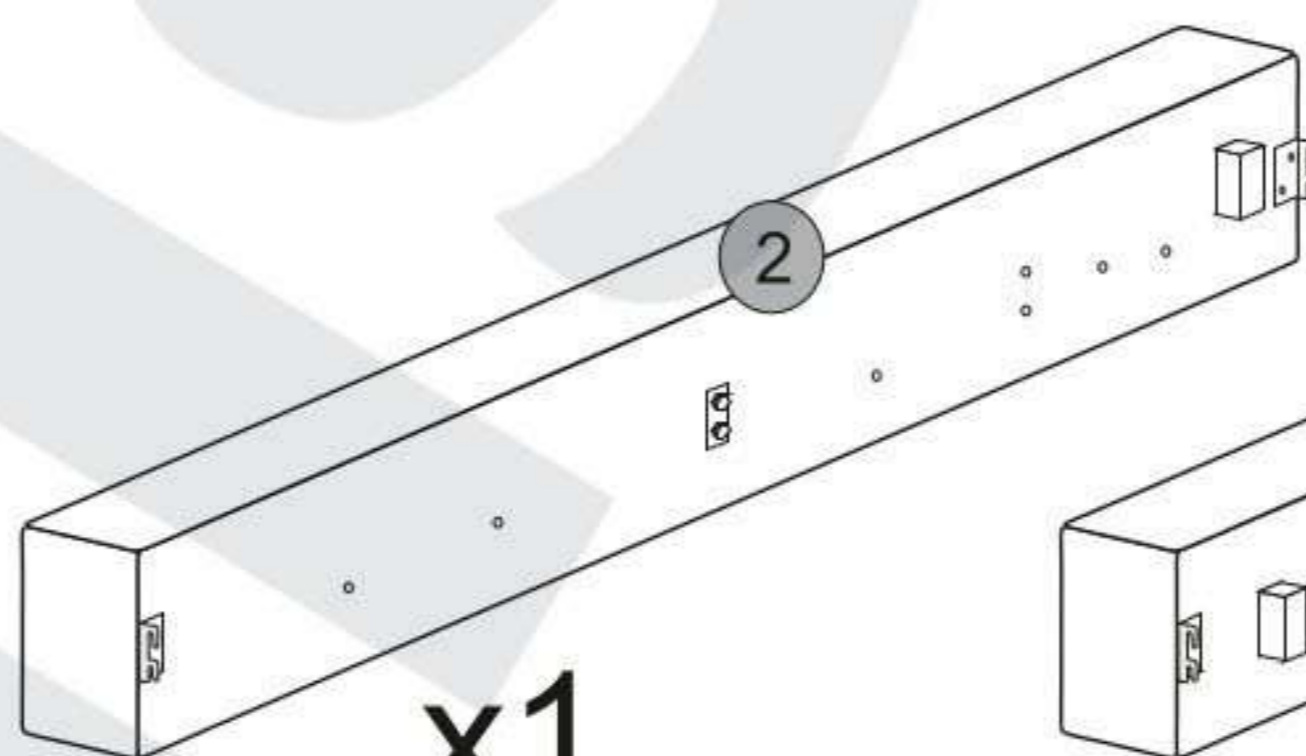

2

x1

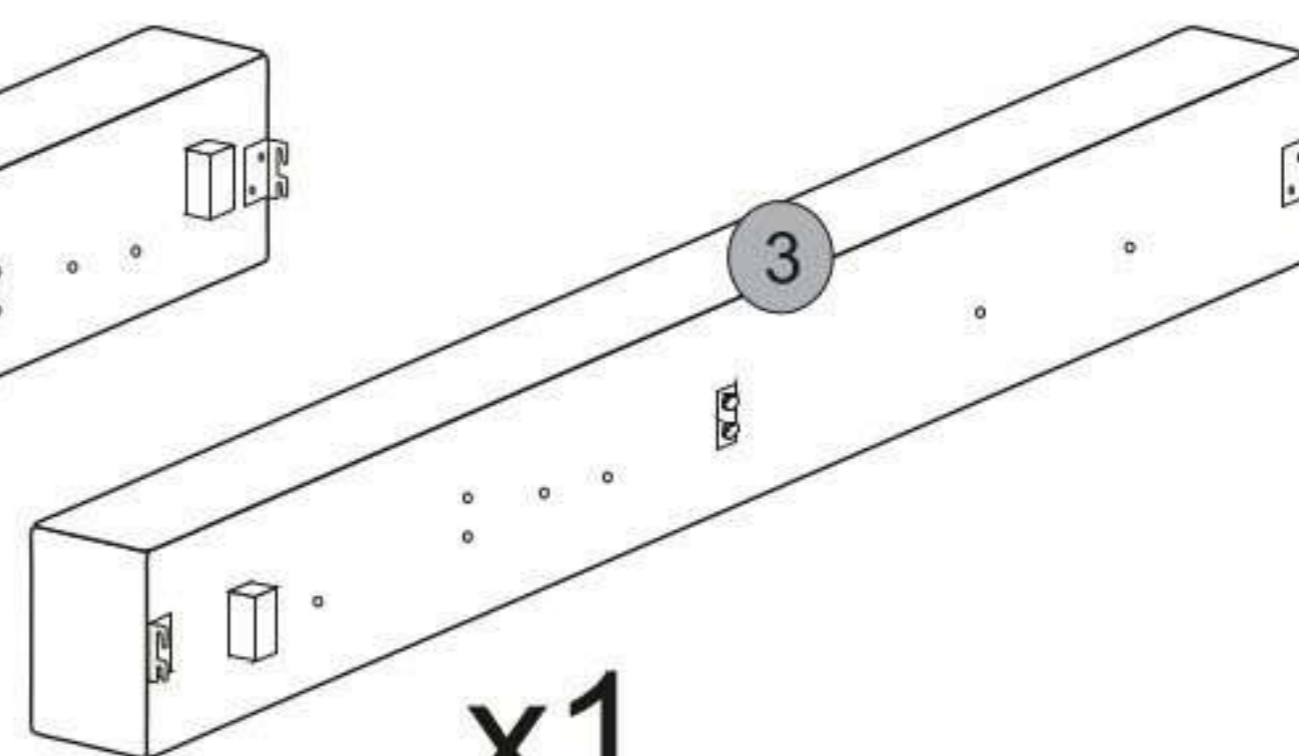

3

x1

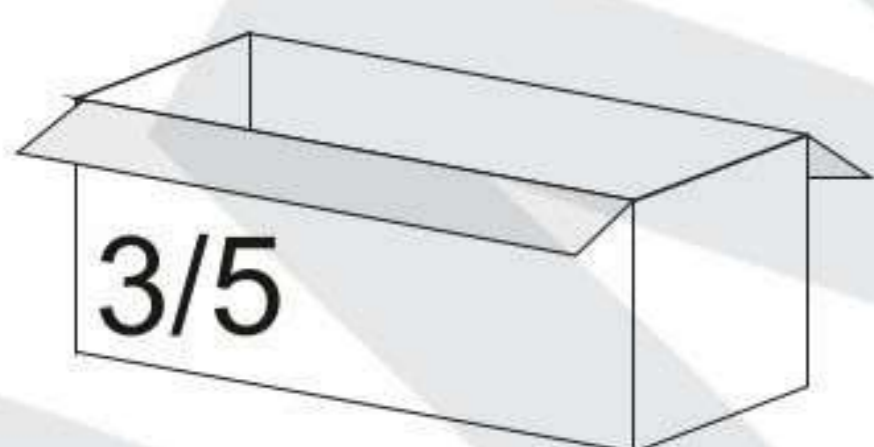

3/5

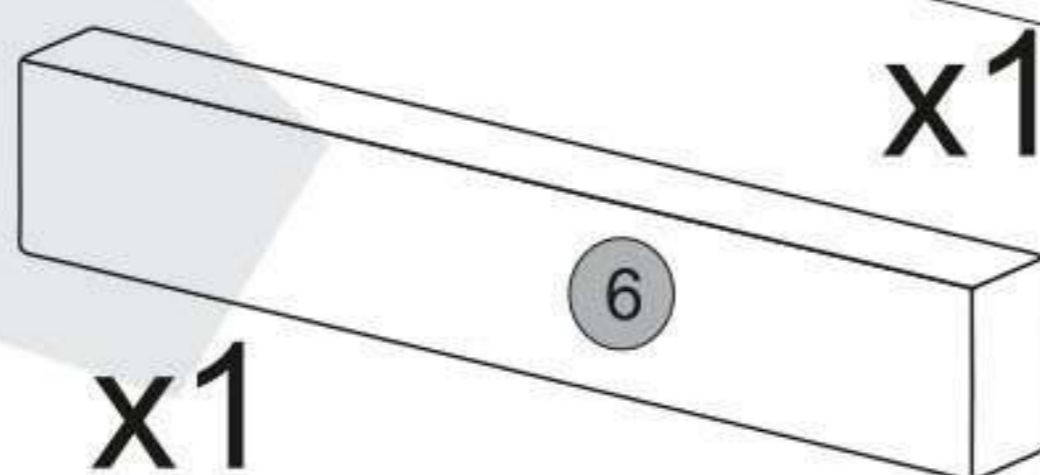

6

x1

x1

4a

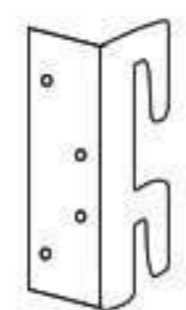

Cx2

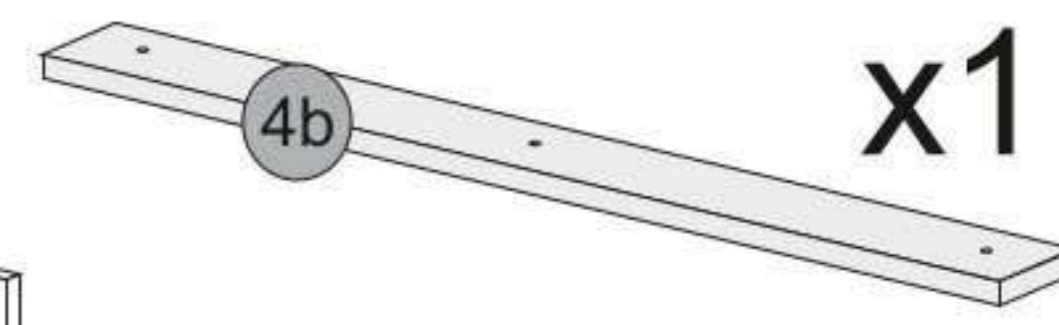

4b







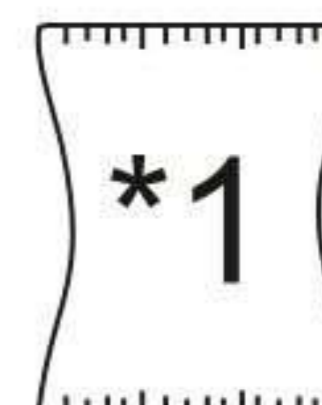



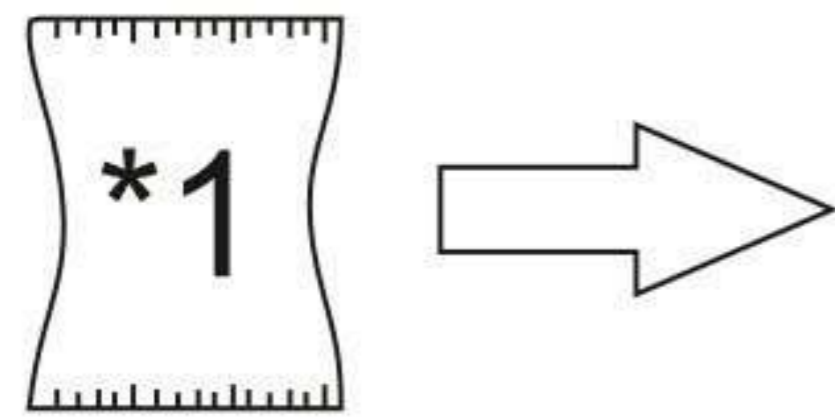
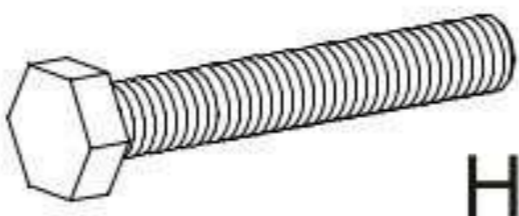
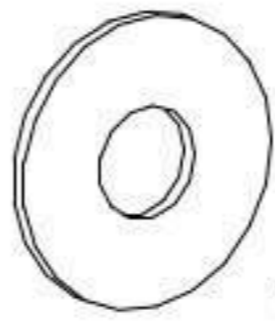

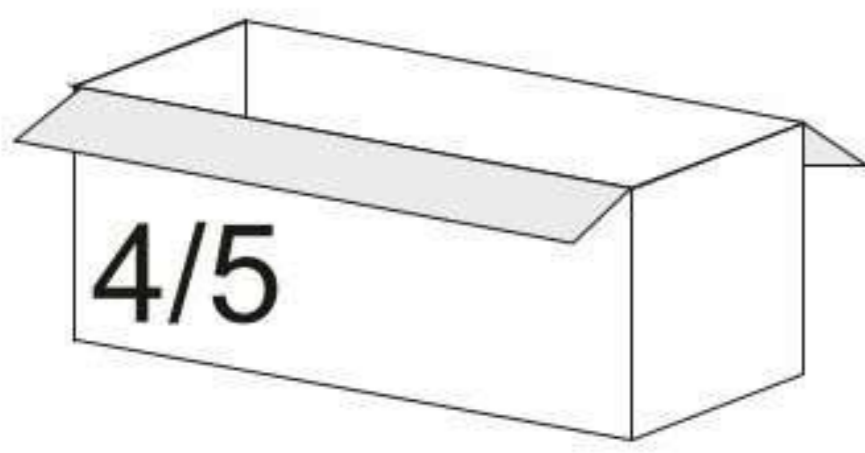
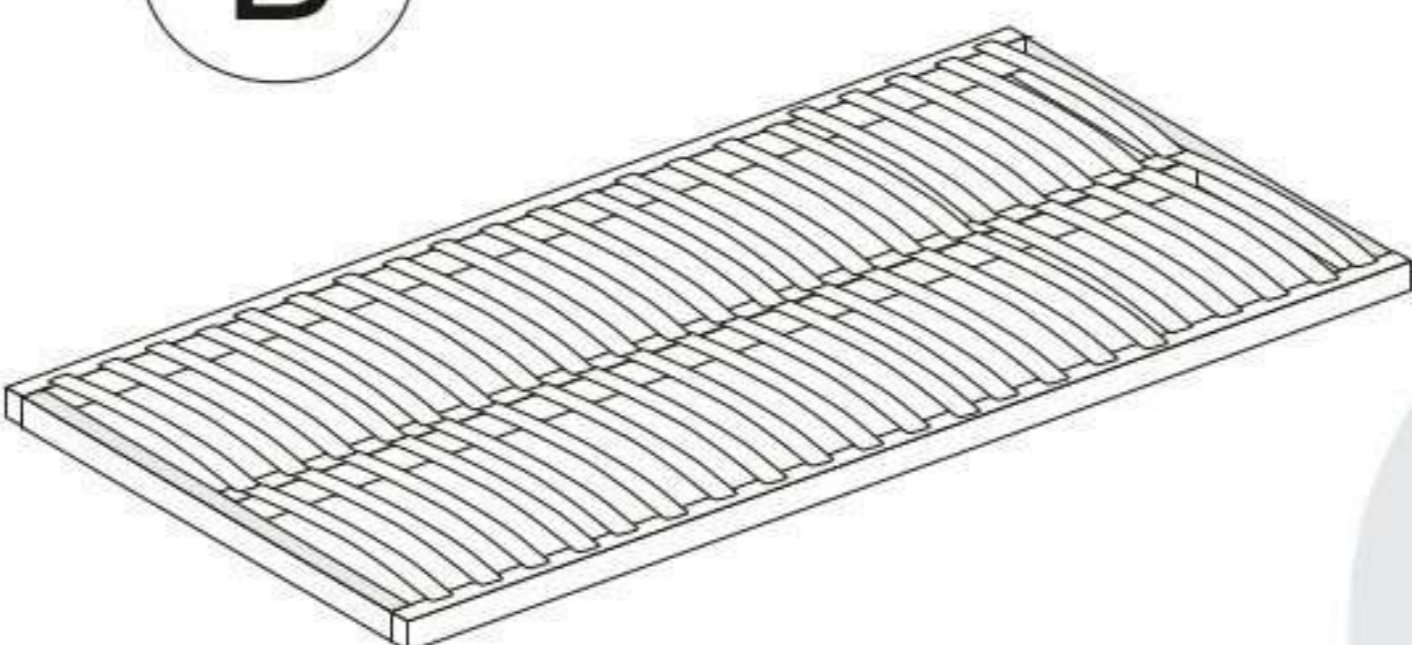
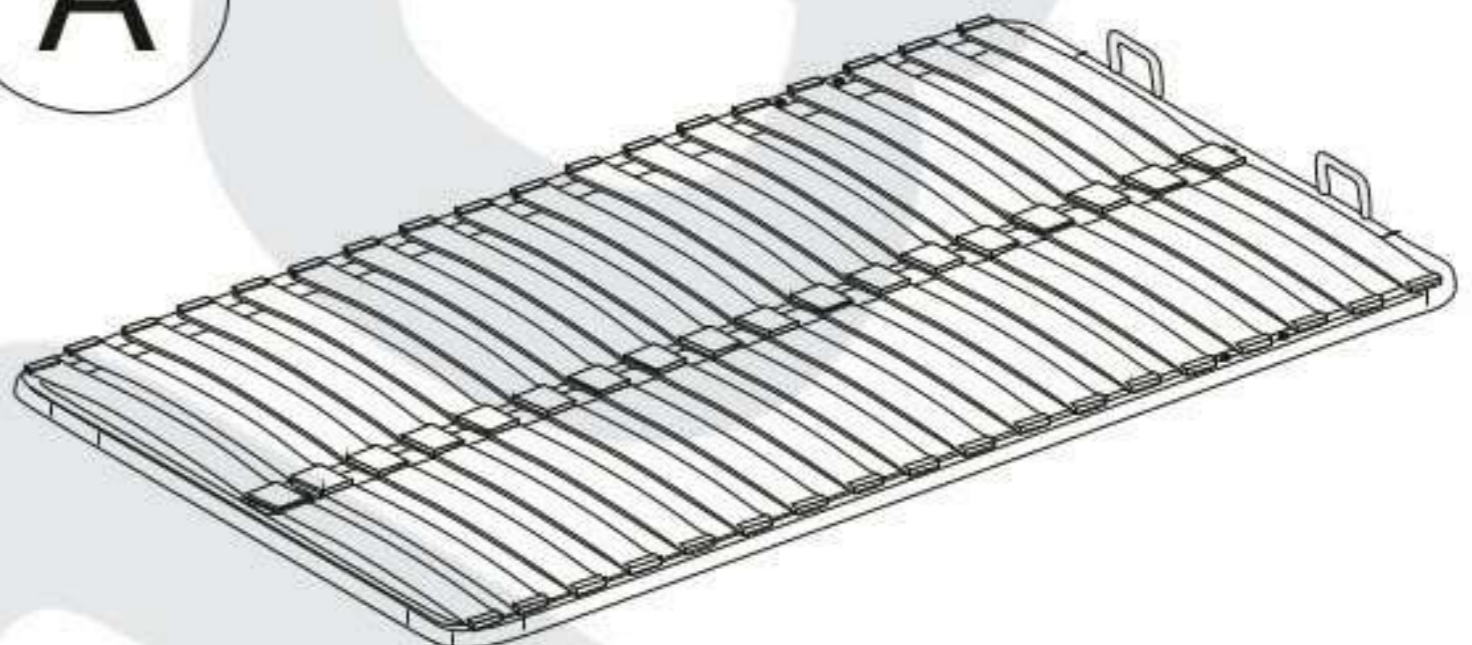
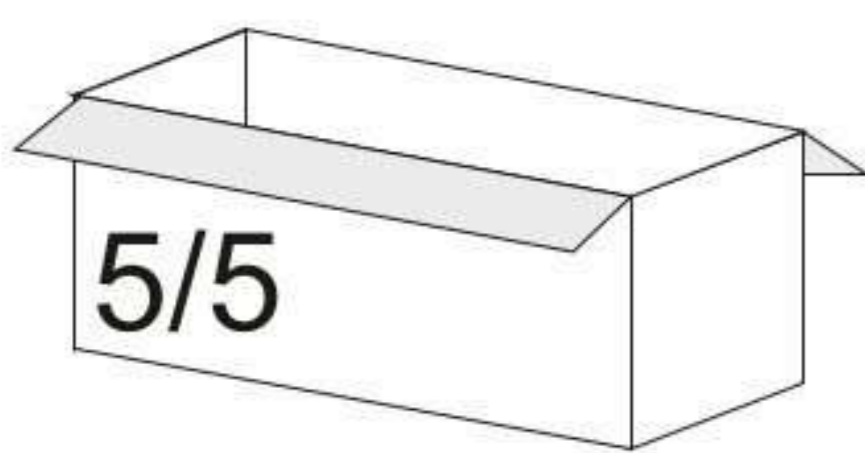
x1

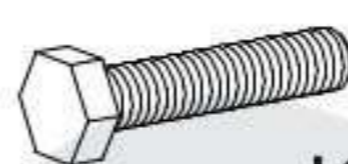
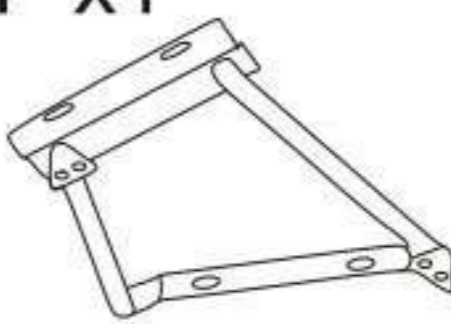
x4

6a

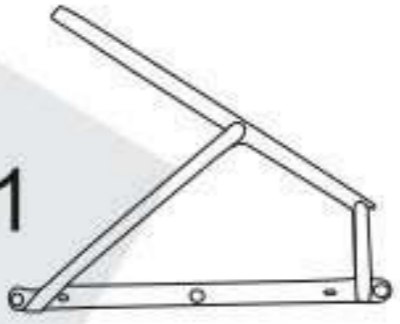
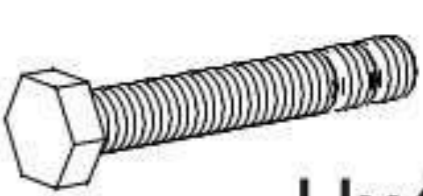
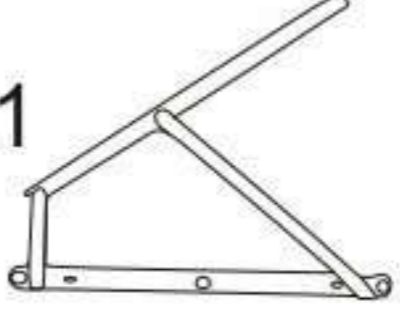
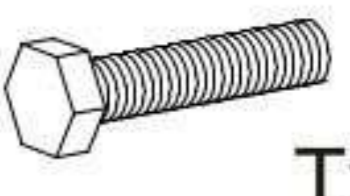
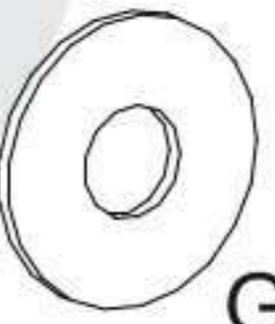

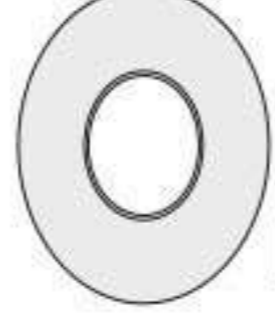
*1

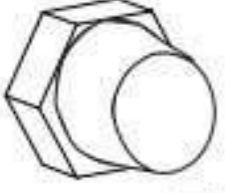
	<p>M6x70</p>  <p>Hx8</p> <p>Y</p>  <p>Yx8</p>  <p>Sx3</p>  <p>4x16</p> <p>W1x8</p>	
 <p>4/5</p>	<p>B</p> 	<p>A</p> 
 <p>5/5</p>	<p>DL x1</p>  <p>M6x30</p>  <p>Kx4</p> <p>DP x1</p>  <p>Gx8</p>  <p>Ax4</p>  <p>Bx4</p>  <p>Rx4</p> 	<p>ML x1</p>  <p>M6x40</p>  <p>Ux4</p> <p>MP x1</p>  <p>M6x35</p>  <p>Tx6</p> <p>Gx10</p>  <p>Qx2</p>  <p>Px8</p>  <p>Rx4</p>  <p>Zx4</p> 

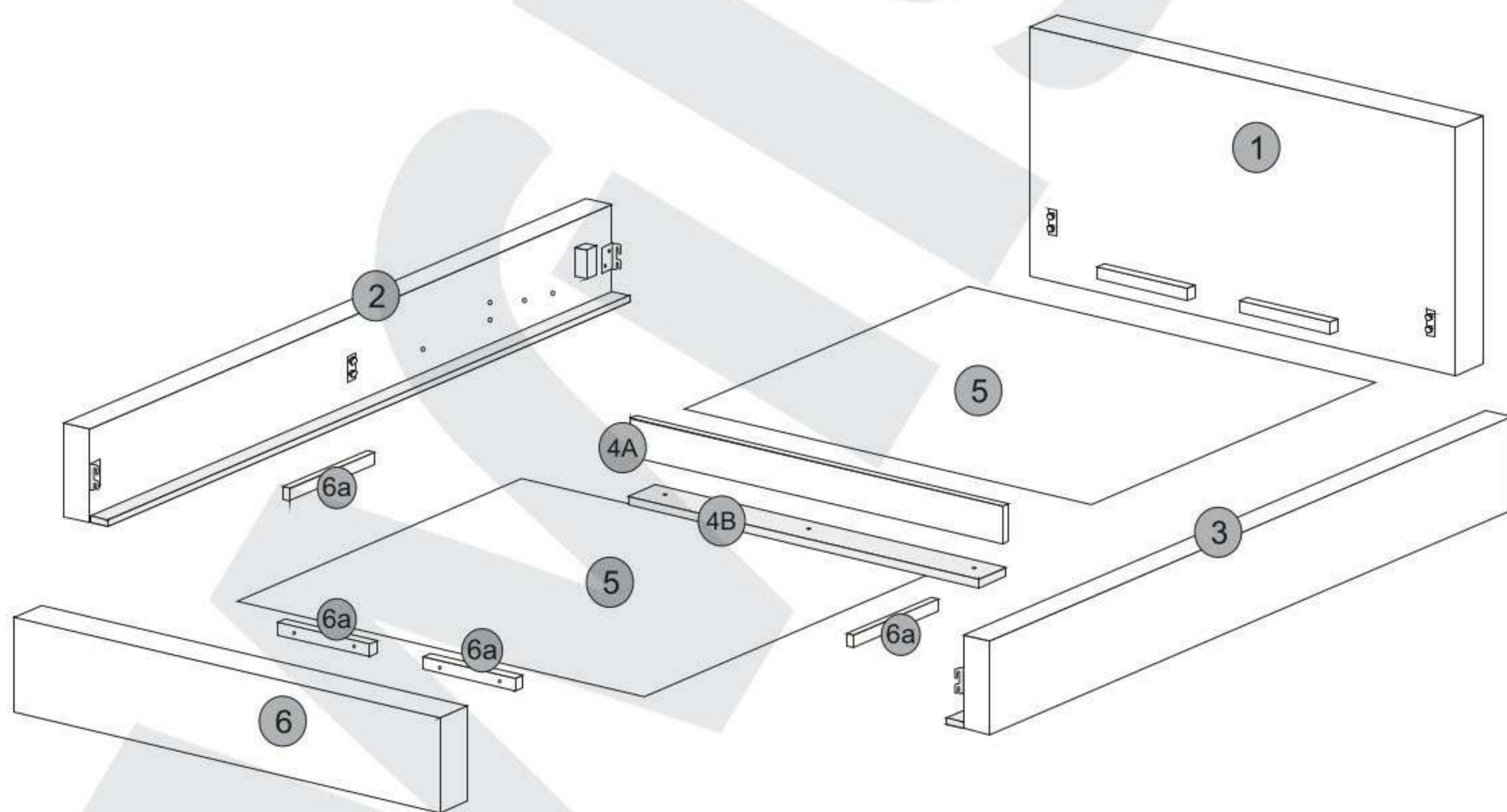

Stelaż łóżka / Der
bettrost / Bedstead /
Sommier / Rošt /
Rošt / Ágyrácsok /
Podnice



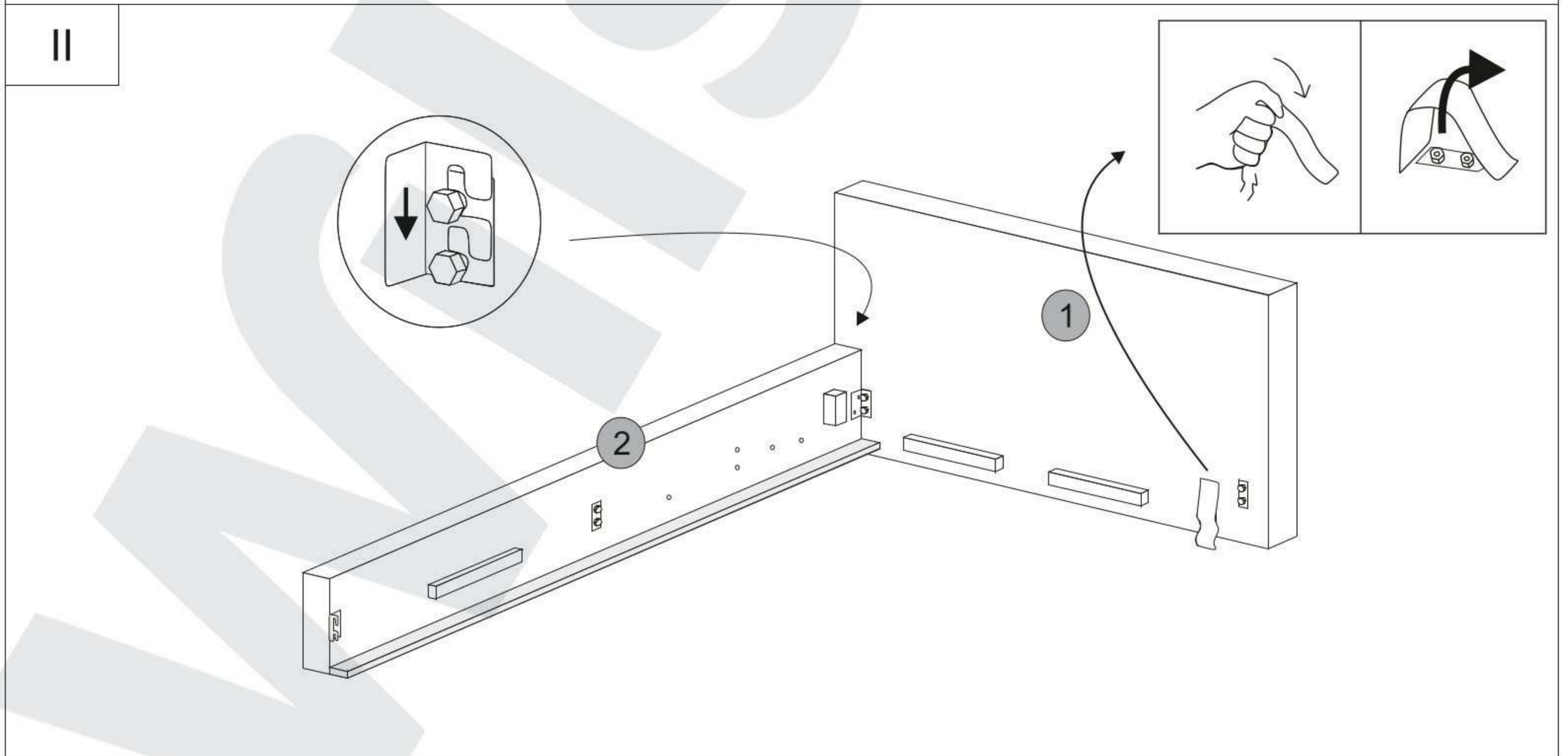
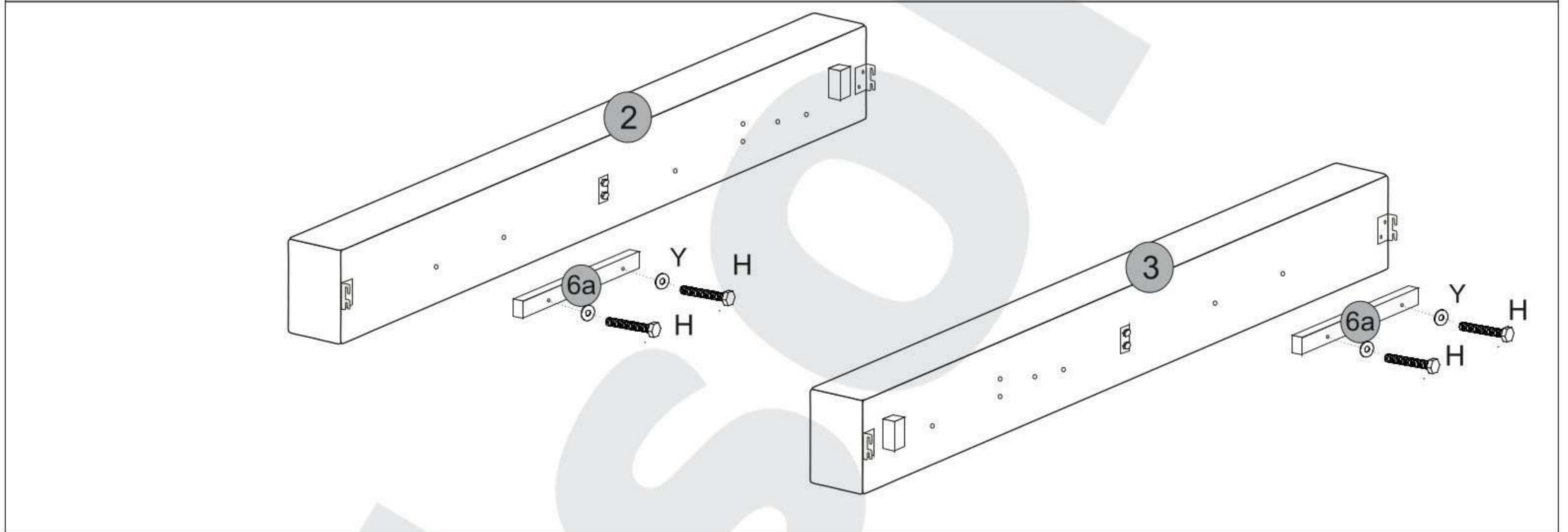
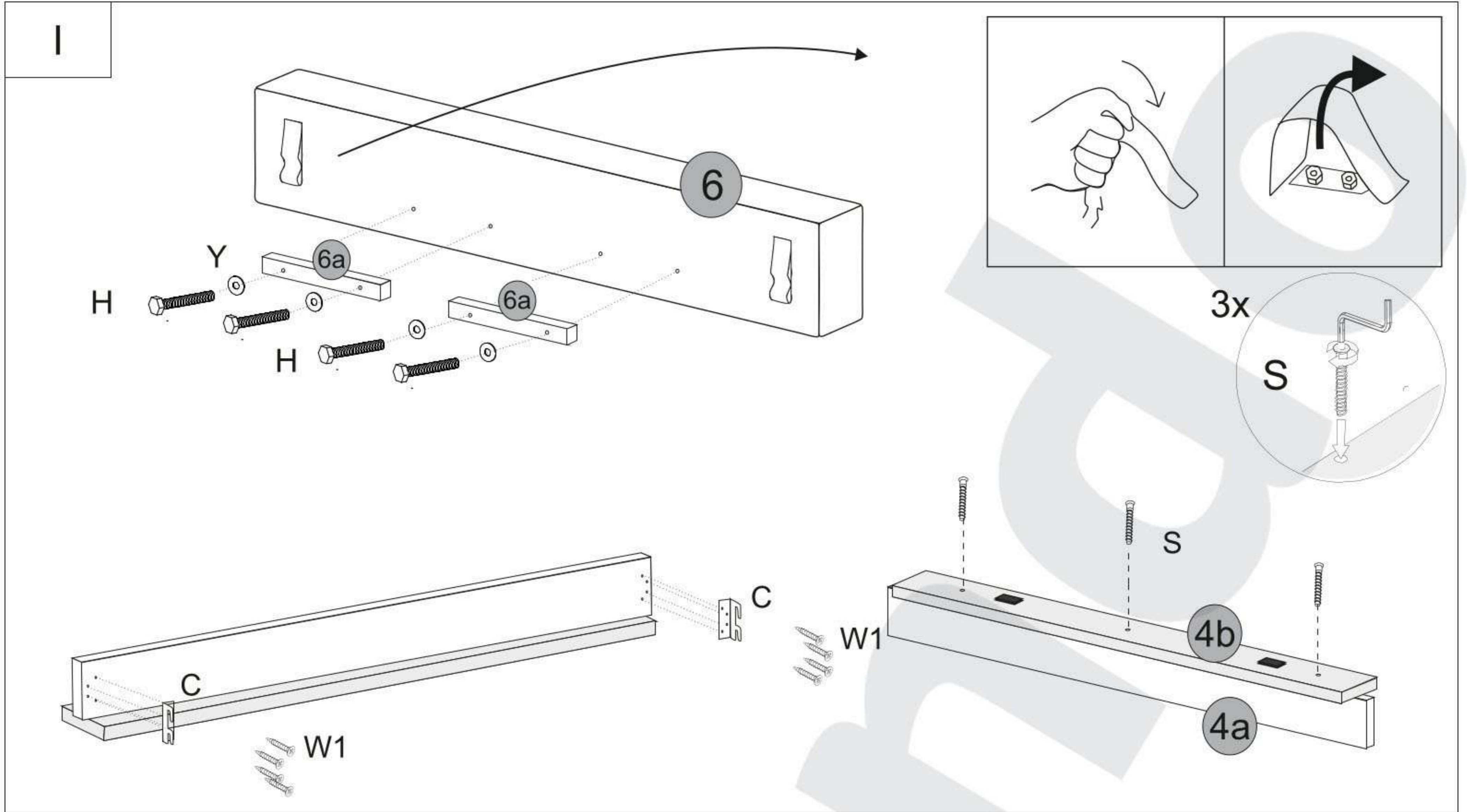

III

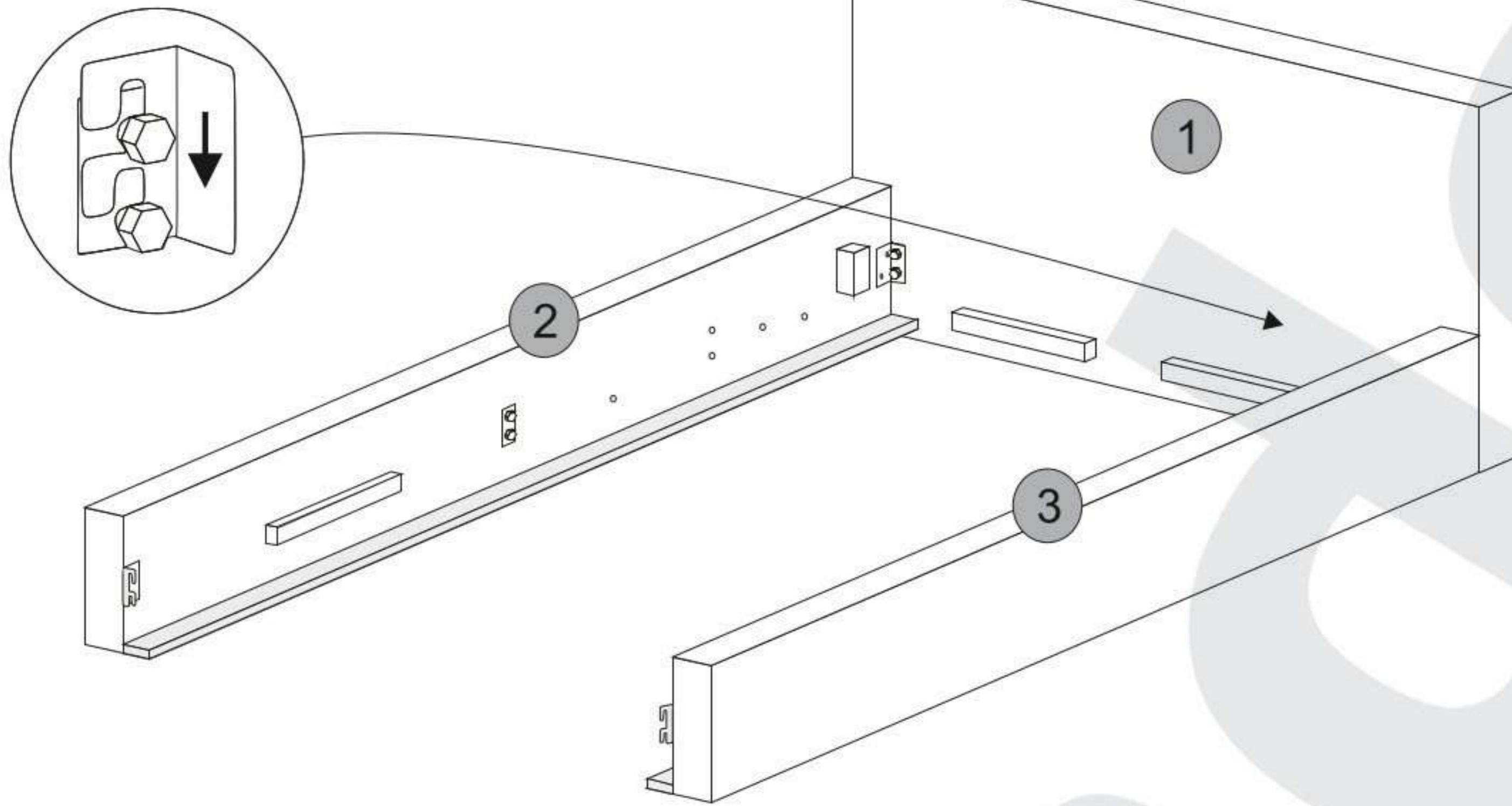

IV

PL: Wykonaj tą czynność ostrożnie.

D: Machen sie ihre arbeit sorgfältig.

GB: Please, do it carefully.

FR: Veuillez effectuer cette opération avec précaution.

SK: Prosím, tento krok vykonajte opatrne.

CZ: Prosím, proveďte tento krok opatrně.

HU: Kérjük, ezt a lépést nagyon óvatosan végezze el!

HR: Molimo vas da pažljivo izvršite ovaj korak.

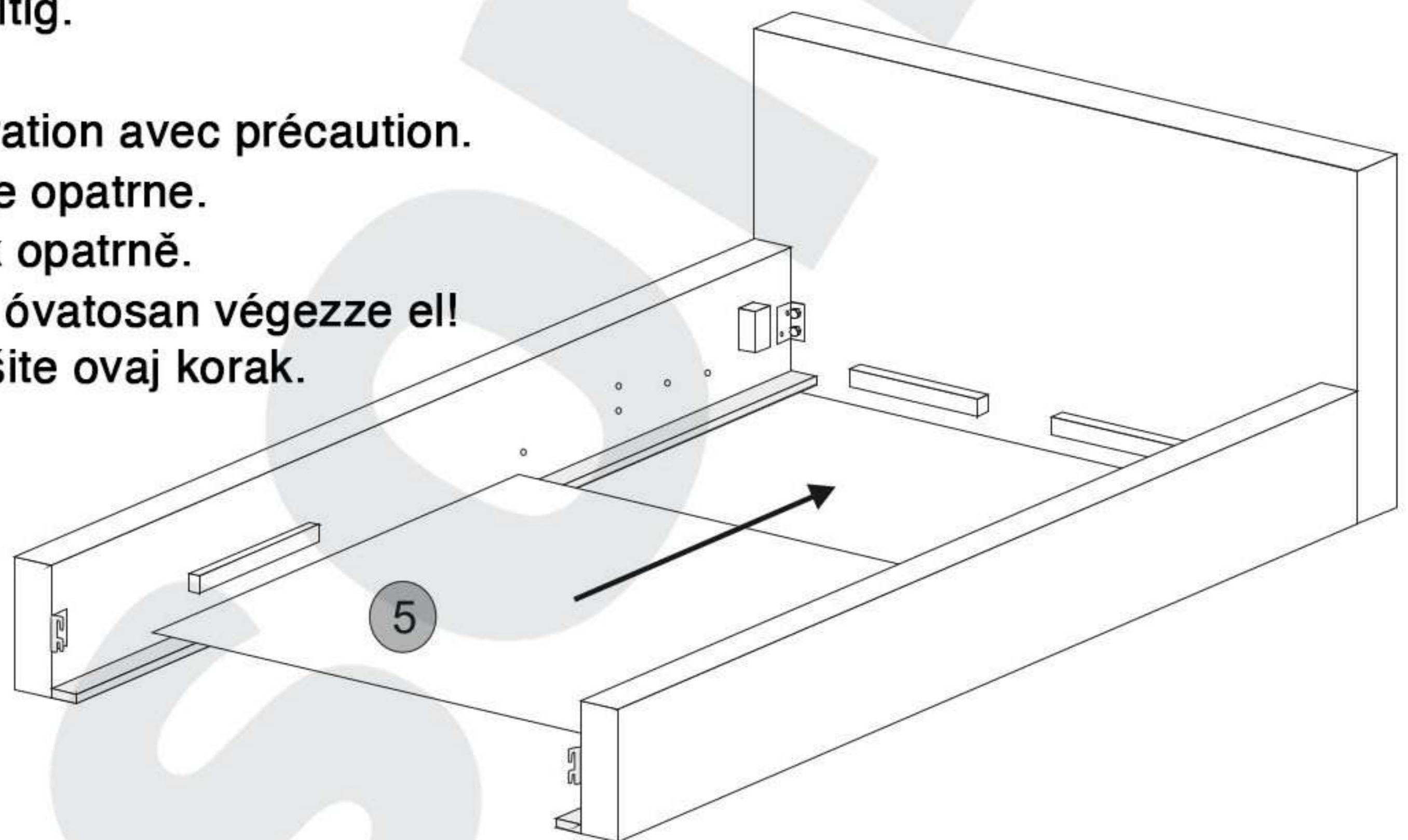

V

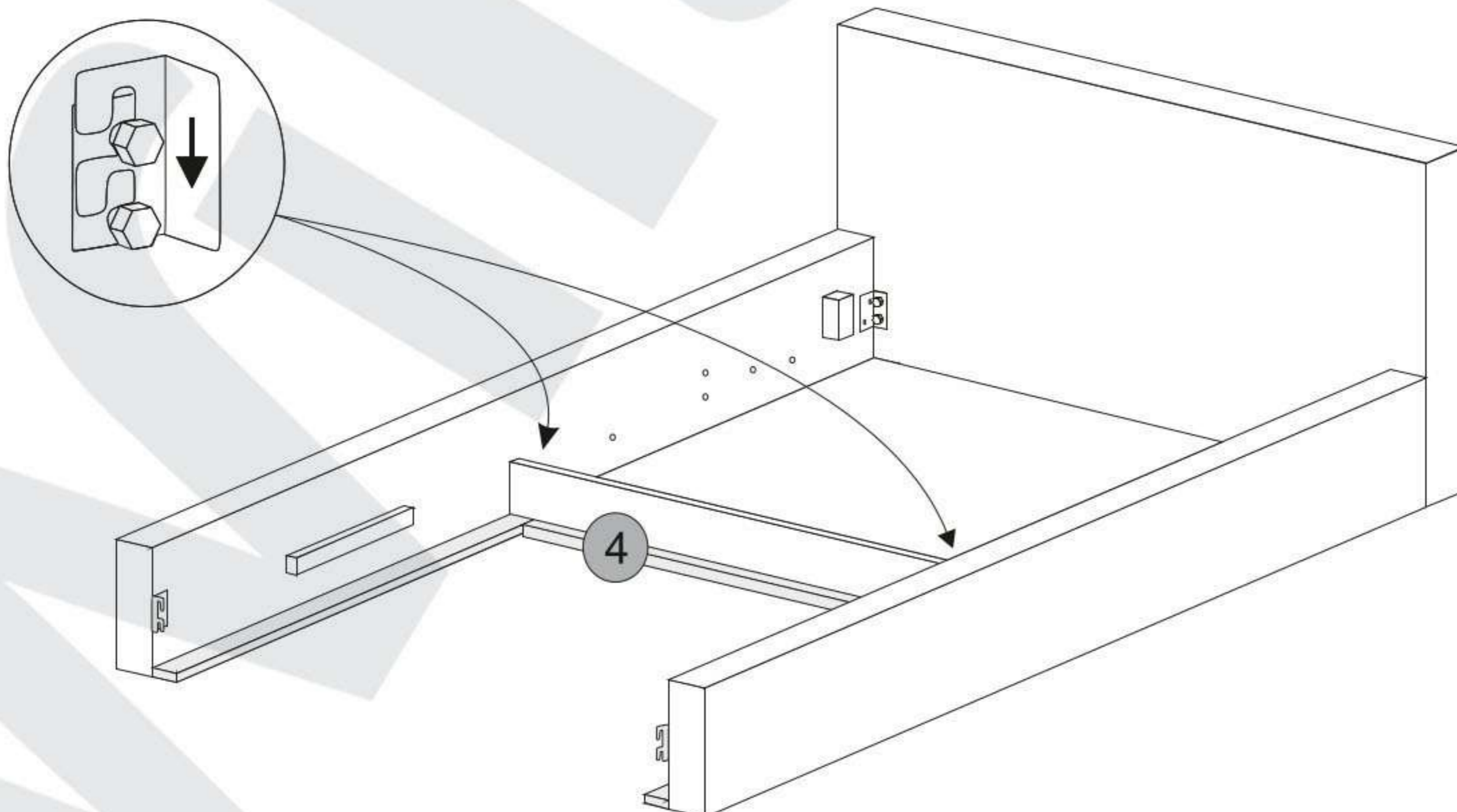

VI

PL: Wykonaj tą czynność ostrożnie.

D: Machen sie ihre arbeit sorgfältig.

GB: Please, do it carefully.

FR: Veuillez effectuer cette opération avec précaution.

SK: Prosím, tento krok vykonajte opatrne.

CZ: Prosím, proveďte tento krok opatrně.

HU: Kérjük, ezt a lépést nagyon óvatosan végezze el!

HR: Molimo vas da pažljivo izvršite ovaj korak.

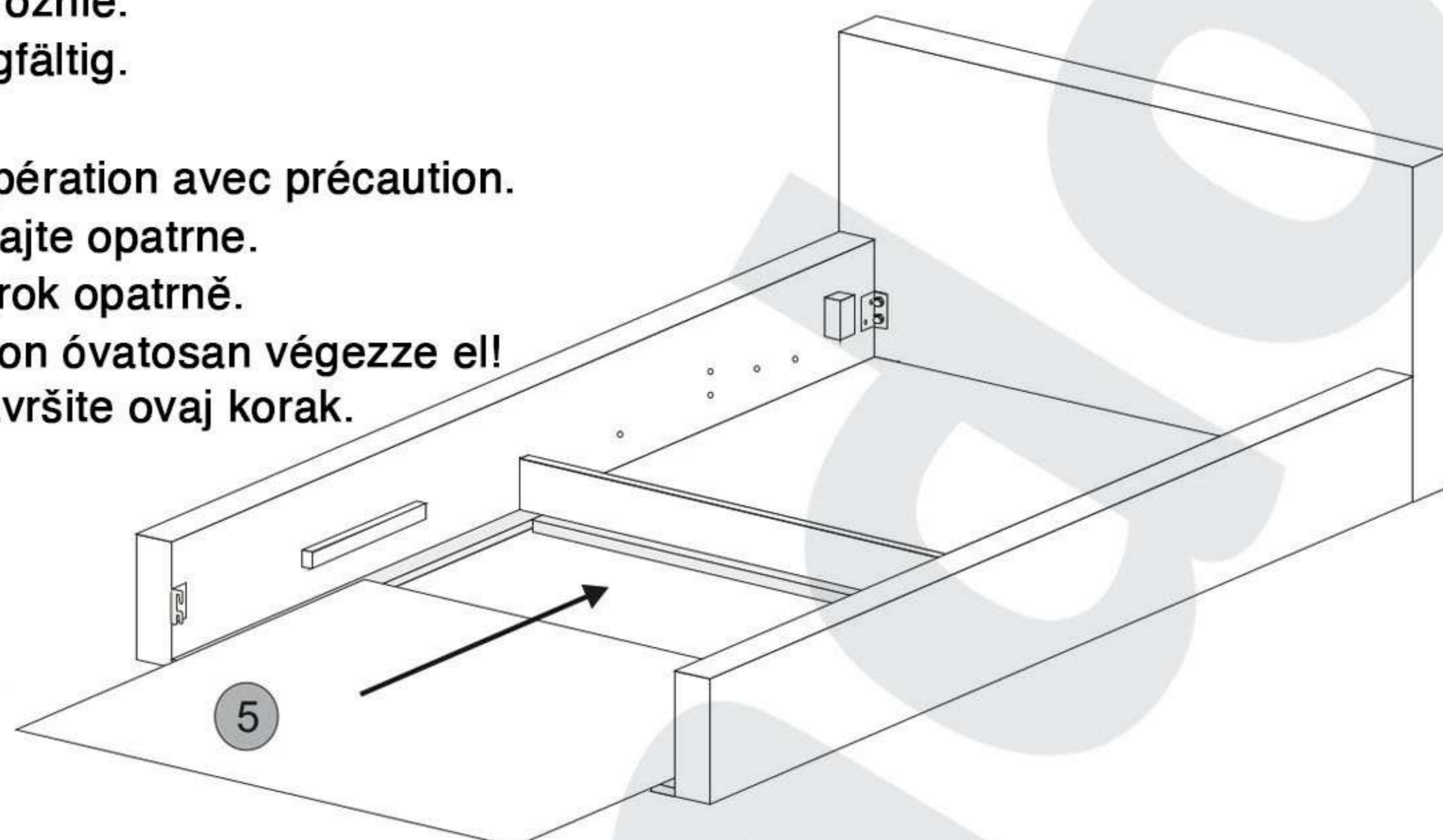

VII

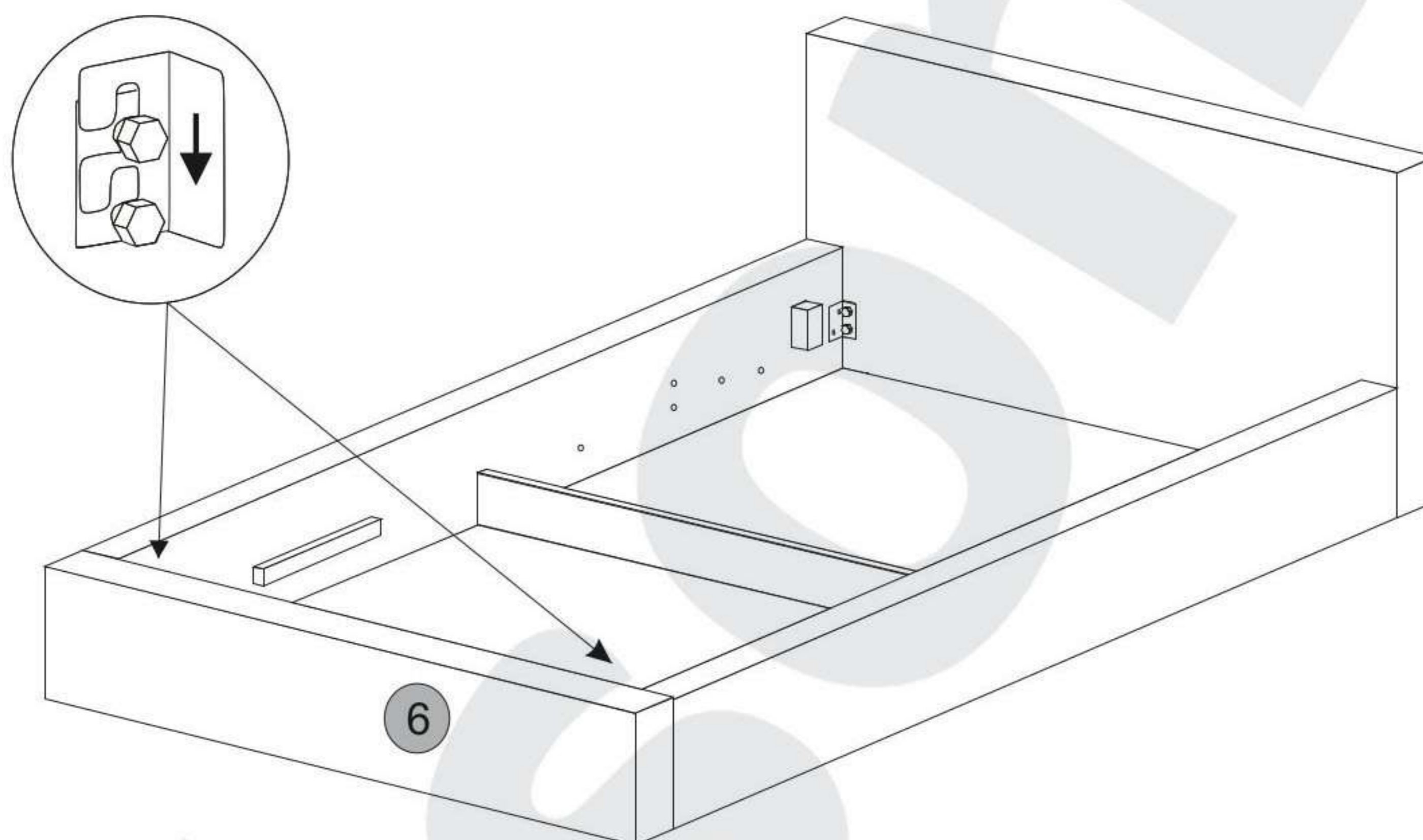

VIII

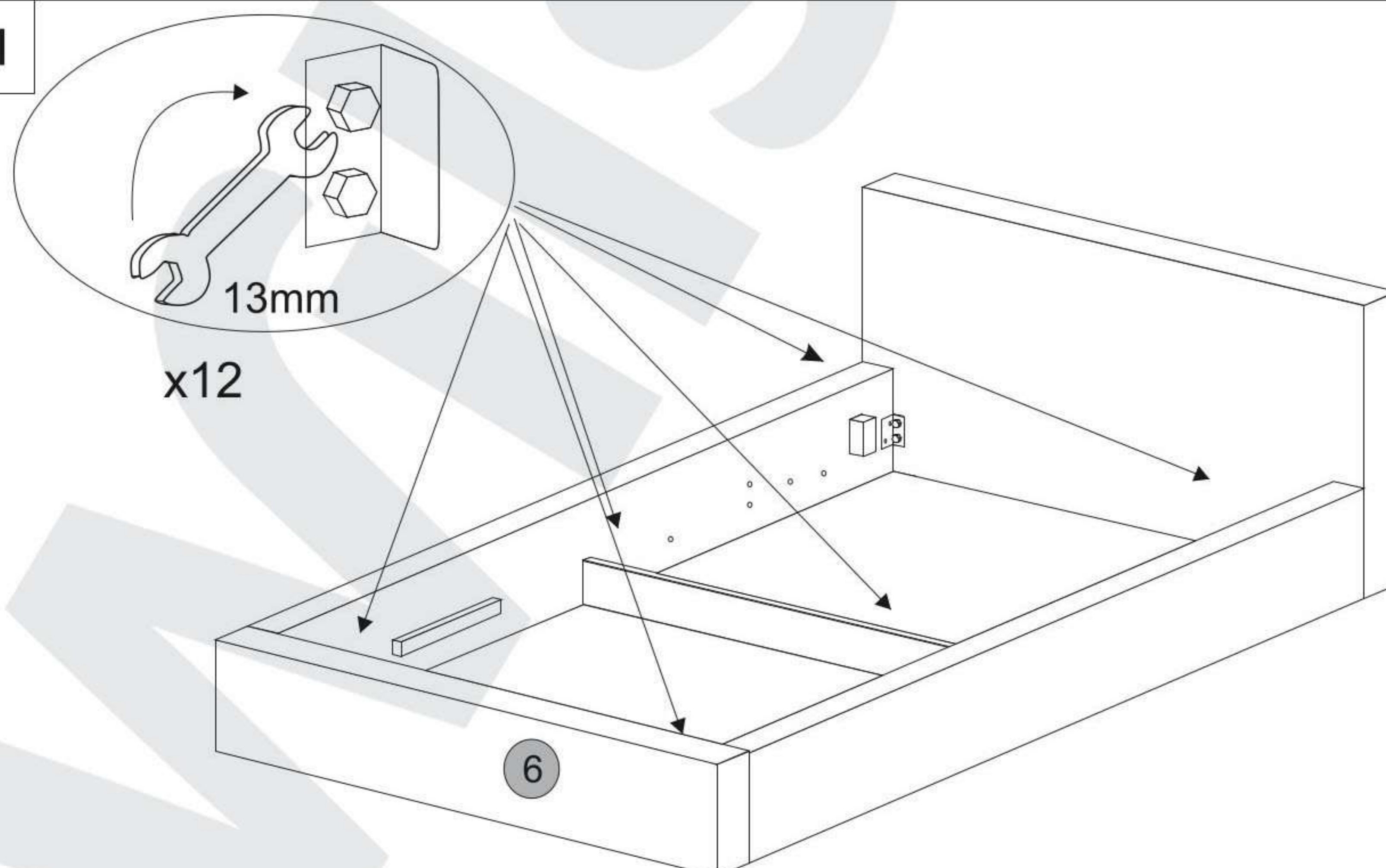

**Opcja A / Option A / Možnosť A /
Možnosť A / A Lehetőség / Opcija A**

(stelaž metalowy / holz metall / metal frame /
armature métallique / kovový rošt / kovový rošt /
fém keret / metalni okvir)

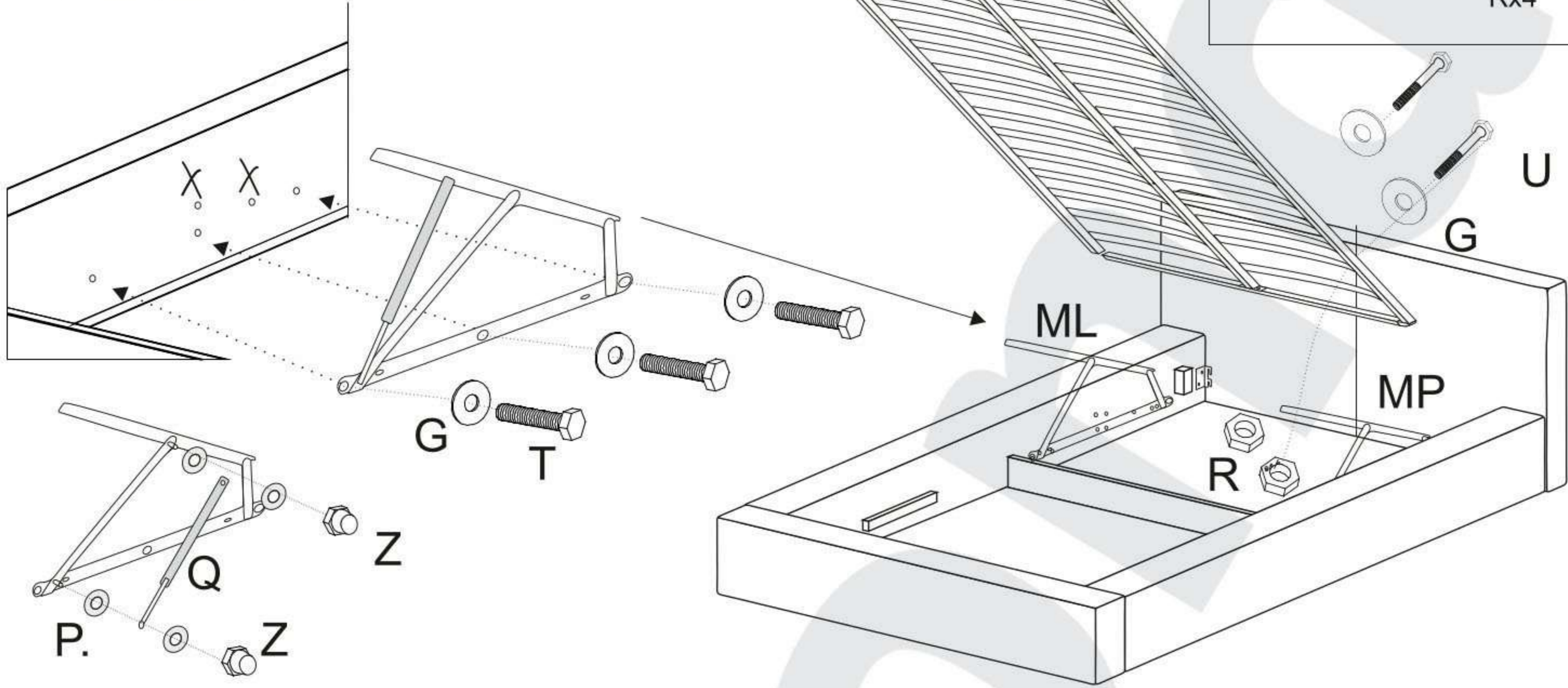
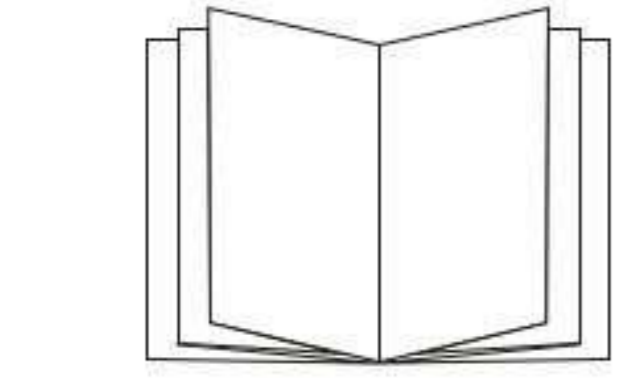
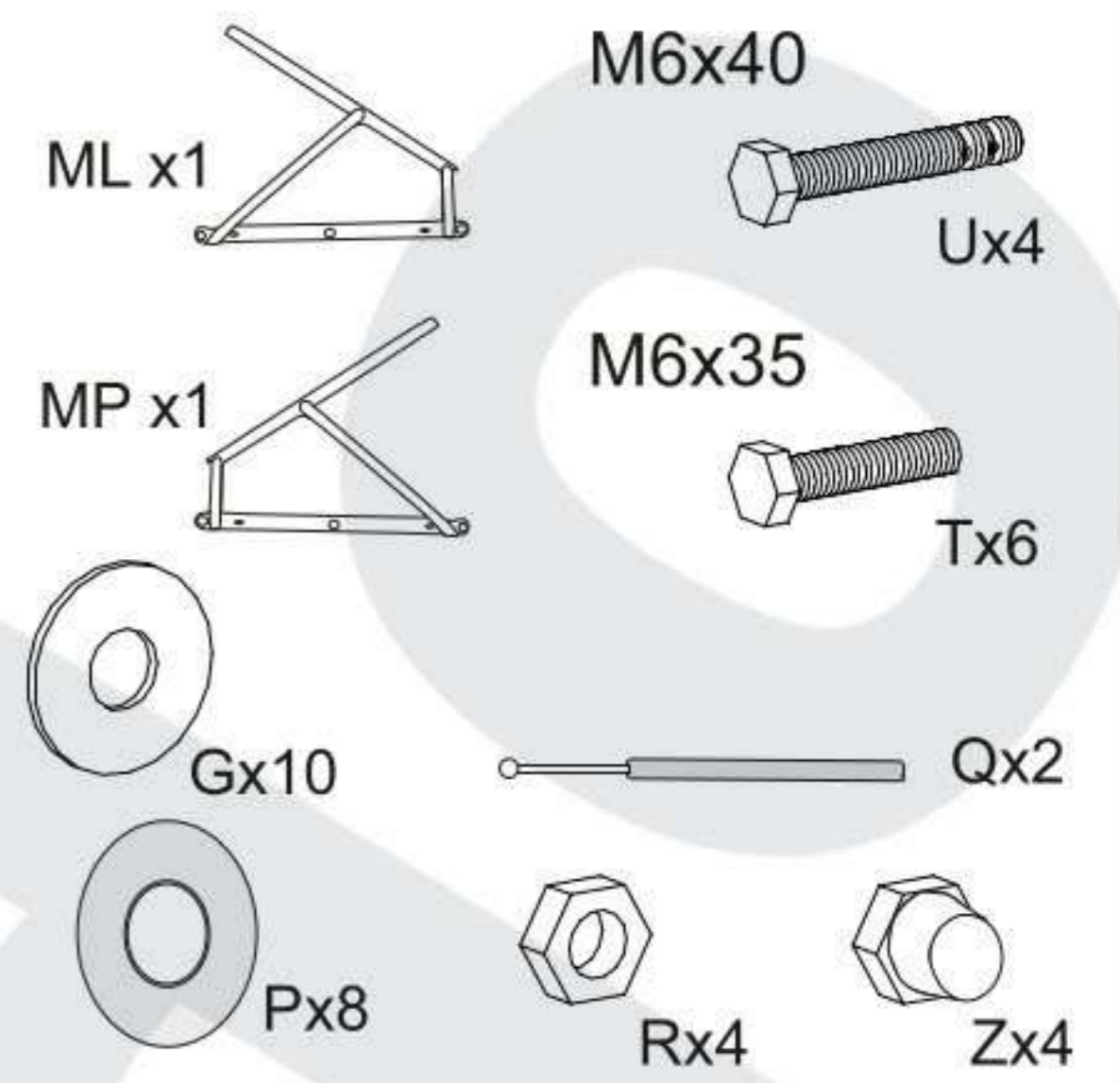
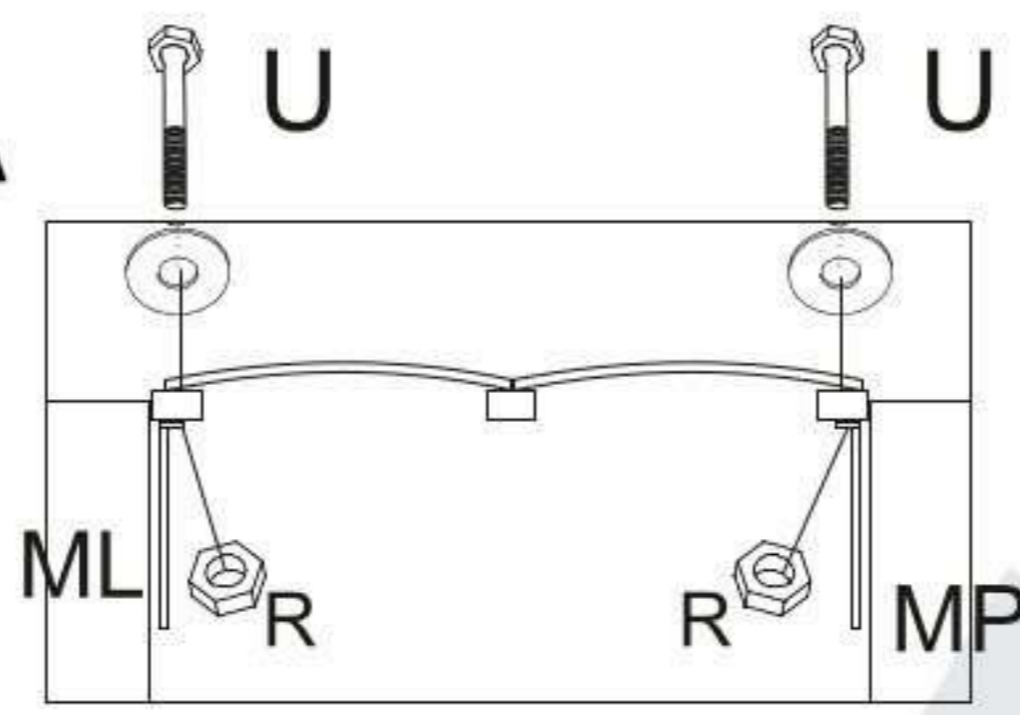

**Opcja B / Option B / Možnosť B /
Možnosť B / B Lehetőség / Opcija B**

(stelaž drewniany / holzrehmen /
wooden frame / cadre en bois /
drevený rošt / dřevěný rošt /
Fa keret / drveni okvir)

