



PL -Montaż powinien być przeprowadzony zgodnie z instrukcją montażu producenta, w przeciwnym razie może pojawić się niebezpieczeństwo użytkowania.

DE- Die Installation sollte gemäß den Installationsanweisungen des Herstellers erfolgen, da sonst die Gefahr einer Verwendung besteht.

EN- Installation should be carried out in accordance with the manufacturer's installation instructions, otherwise there may be danger of use.

CZ- Instalace by měla být provedena v souladu s instalačními pokyny výrobce, jinak může dojít k nebezpečí použití.

SK- Inštalácia by sa mala vykonávať v súlade s inštaláčnymi pokynmi výrobcu, inak môže existovať nebezpečenstvo použitia.

RU- Установка должна выполняться в соответствии с инструкциями производителя по установке, в противном случае может возникнуть опасность использования.

SRB- Instalaciju treba izvesti u skladu sa uputstvima za ugradnju proizvođača, jer u suprotnom može doći do opasnosti od upotrebe.

HR- Instalaciju treba izvoditi u skladu s uputama za ugradnju proizvođača, jer u suprotnom može doći do opasnosti od uporabe.

HU- A telepítést a gyártó telepítési útmutatója szerint kell elvégezni, különben a használat veszélye áll fenn.

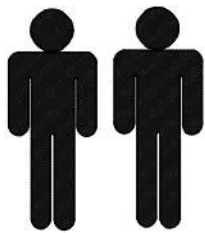

180 min

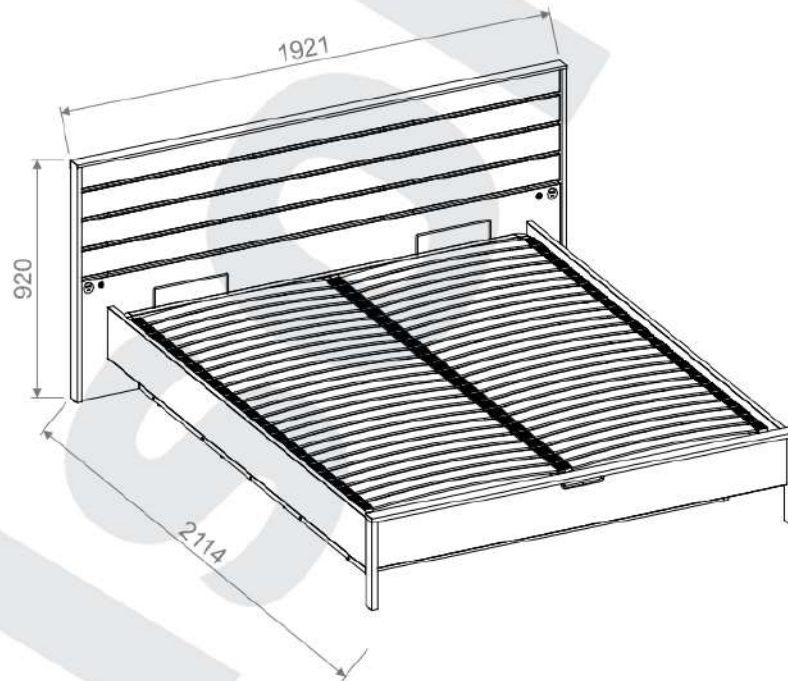

Potrzebne narzędzia/ Benötigtes Werkzeug/ Required tools/ Potřebné nástroje/
Potrebné nástroje/ Необходимые инструменты/ Potreban alat/ Szereléshez szükséges szerszámok

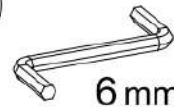
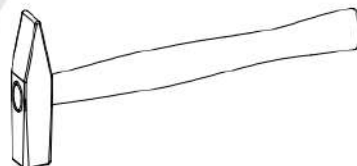
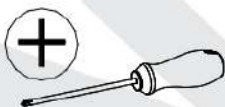

6 mm

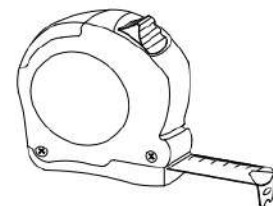

PL - WYMIARY ELEMENTÓW.
 EN - THE DIMENSIONS OF THE ELEMENTS.
 DE - ABMESSUNGEN DER ELEMENTE.
 CZ - ROZMĚRY PRVKŮ.
 SK - ROZMERY PRVKOV.
 RU - РАЗМЕРЫ ЭЛЕМЕНТОВ.
 SRB - DIMENZIJE ELEMENATA.
 HR - DIMENZIJE ELEMENATA.
 HU - A BÚTORELEMÉK MÉRETEI.

01_01	2024,0	196,0	22,0	1	2/5
01_02	2024,0	196,0	22,0	1	2/5
07_11	1779,0	161,0	16,0	1	1/5
07_12	1779,0	161,0	16,0	1	1/5
07_13	1391,0	160,0	16,0	1	3/5
07_14	914,0	119,0	22,0	1	1/5
07_15	914,0	119,0	22,0	2	1/5
07_16	914,0	119,0	22,0	1	1/5
07_17	1763,0	248,0	16,0	1	3/5
07_22	1887,0	99,0	12,0	4	2/5
07_31	1763,0	70,0	16,0	3	1/5
07_32	1763,0	70,0	16,0	2	1/5
07_41	2026,0	99,0	16,0	1	2/5
07_42	1423,0	247,0	16,0	1	3/5
07_43	2026,0	99,0	16,0	1	2/5
07_61	1621,0	105,0	16,0	1	3/5
07_62	105,0	70,0	16,0	2	1/5
10_31	1763,0	343,0	3,0	4	3/5
14_11	1887,0	458,0	16,0	1	3/5
14_21	1621,0	196,0	16,0	1	2/5
17_23	1667,0	52,0	16,0	1	3/5
17_71	338,0	50,0	22,0	1	1/5
17_72	338,0	50,0	22,0	1	1/5
17_73	914,0	50,0	16,0	2	1/5

15
14
13
12
11
10
9
8
7
6
5
4
3
2
1
0

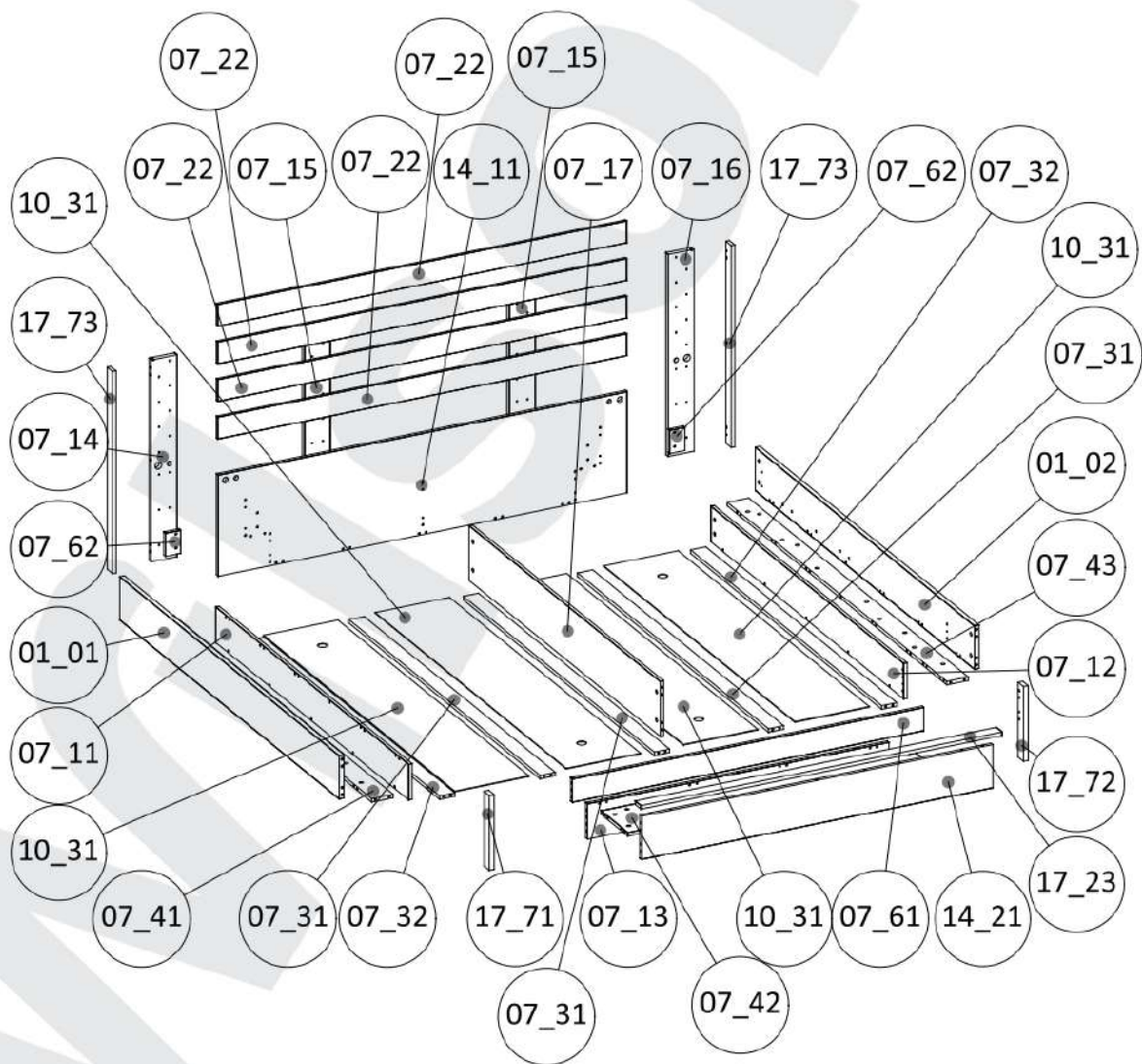

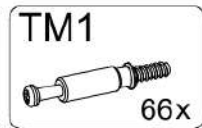
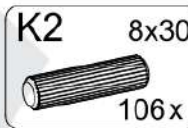
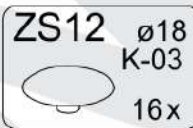
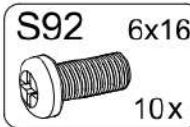
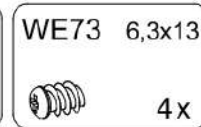
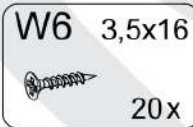
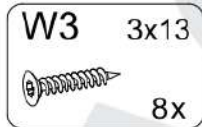
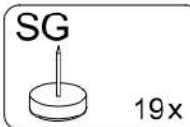
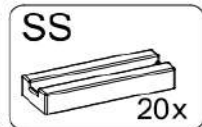
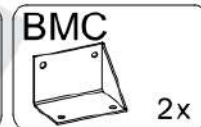
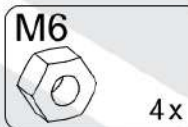
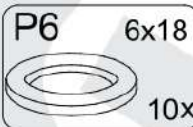
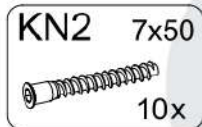
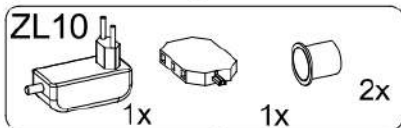
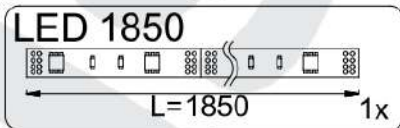
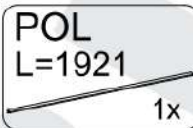
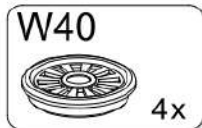
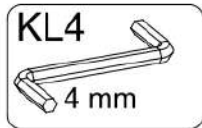
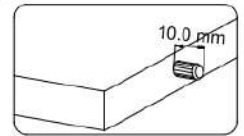
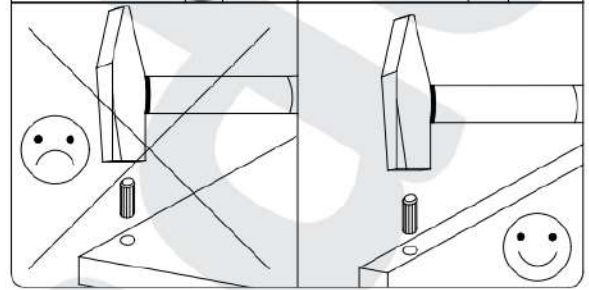
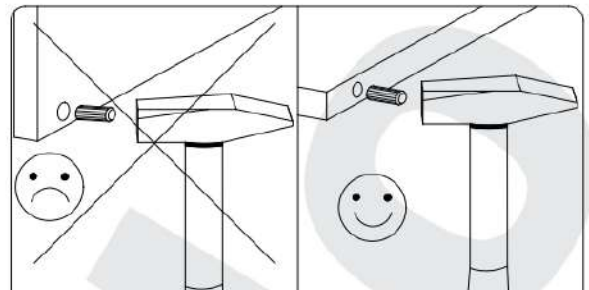
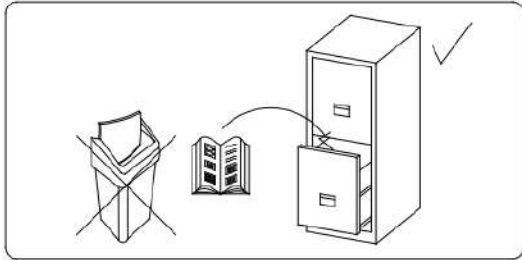
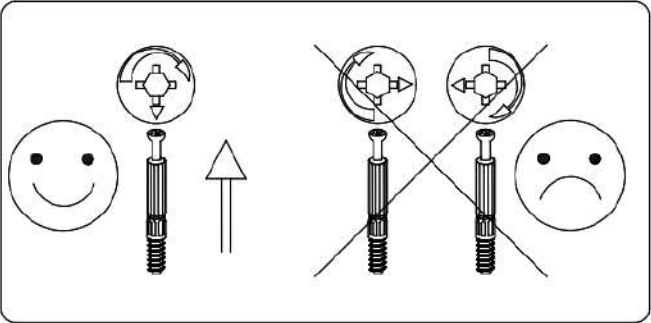
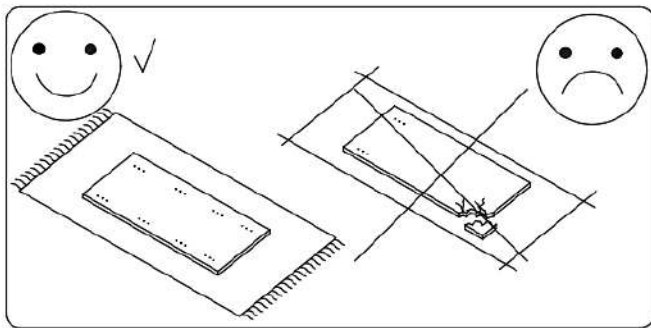

Proszę sprawdzić kompletność okuć przed montażem
Bitte überprüfen Sie die Vollständigkeit der Fittings vor der Montage
Please check the completeness of the fittings before assembly
Пожалуйста, проверьте комплектность фурнитуры перед установкой

Prosím zkontrolujte úplnost konektorů před instalací
Prosím skontrolujte úplnosť konektorov pred inštaláciou
Prije montaže provjerite cjelovitost okova
Pre postavljanja proverite kompletnost okova
Kérjük, ellenőrizze a szerelvények teljességét a szerelés előtt

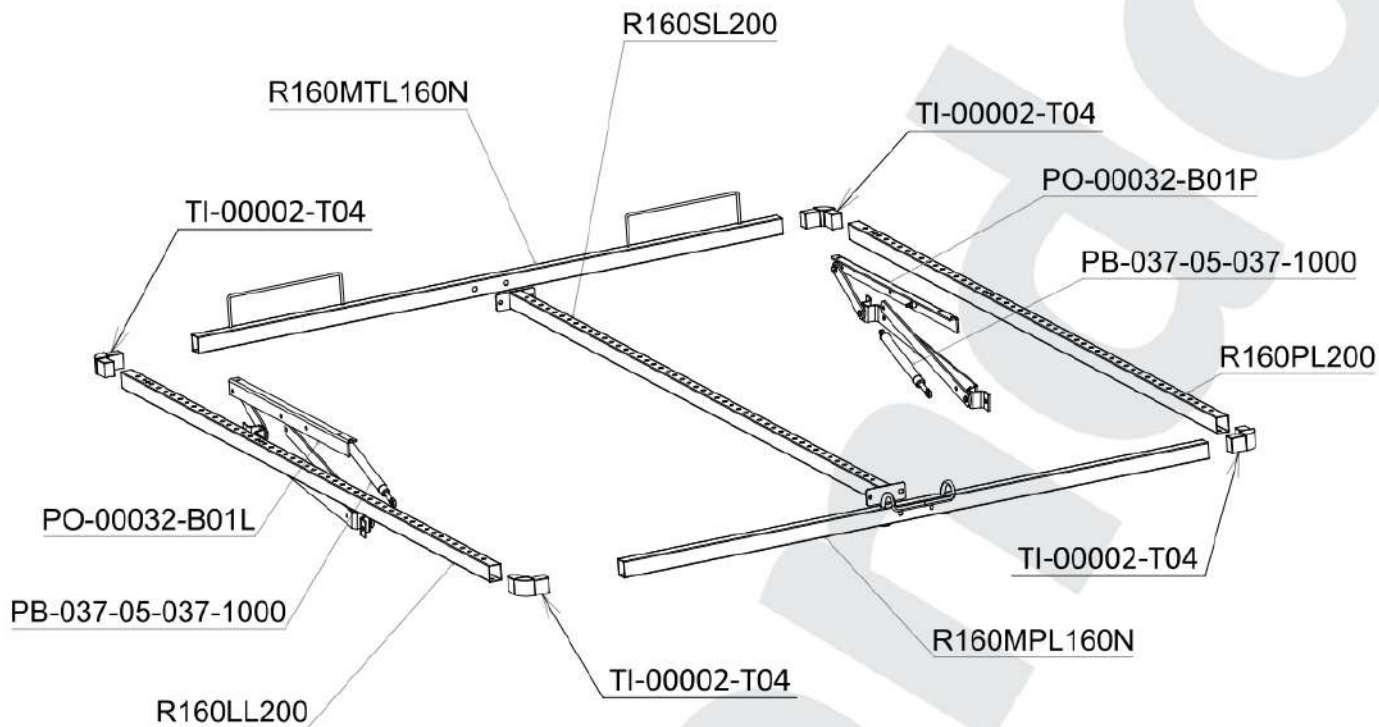

PL - WYMIARY ELEMENTÓW.
 EN - THE DIMENSIONS OF THE ELEMENTS.
 DE - ABMESSUNGEN DER ELEMENTE.
 CZ - ROZMĚRY PRVKŮ.
 SK - ROZMERY PRVKOV.
 RU - РАЗМЕРЫ ЭЛЕМЕНТОВ.
 SRB - DIMENZIJE ELEMENATA.
 HR - DIMENZIJE ELEMENATA.
 HU - A BÚTORELEMÉK MÉRETEI.

Box 4/5

PB-037-05-037-1000	216,0	21,0	21,0	2	4/5
PO-00032-B01L	620,0	37,0	23,0	1	4/5
PO-00032-B01P	620,0	37,0	23,0	1	4/5
TI-00002-T04	73,9	73,9	38,0	4	4/5

Box 5/5

R160LL200	1931,0	40,0	30,0	1	5/5
R160MPL160N	1516,0	40,0	30,0	1	5/5
R160MTL160N	1516,0	40,0	30,0	1	5/5
R160PL200	1931,0	40,0	30,0	1	5/5
R160SL200	1933,0	40,0	30,0	1	5/5

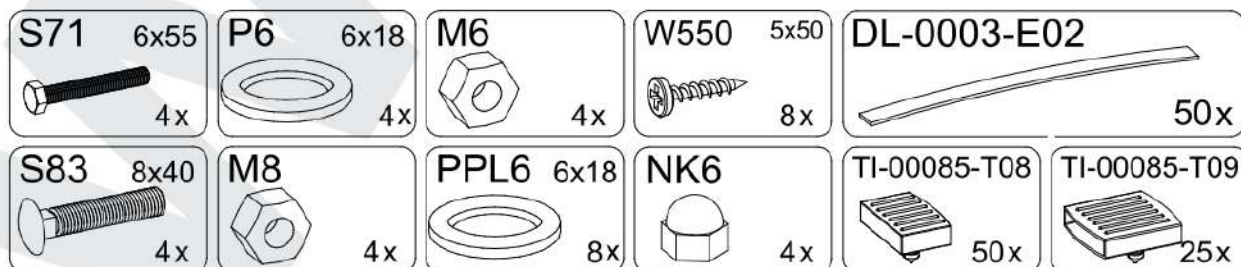

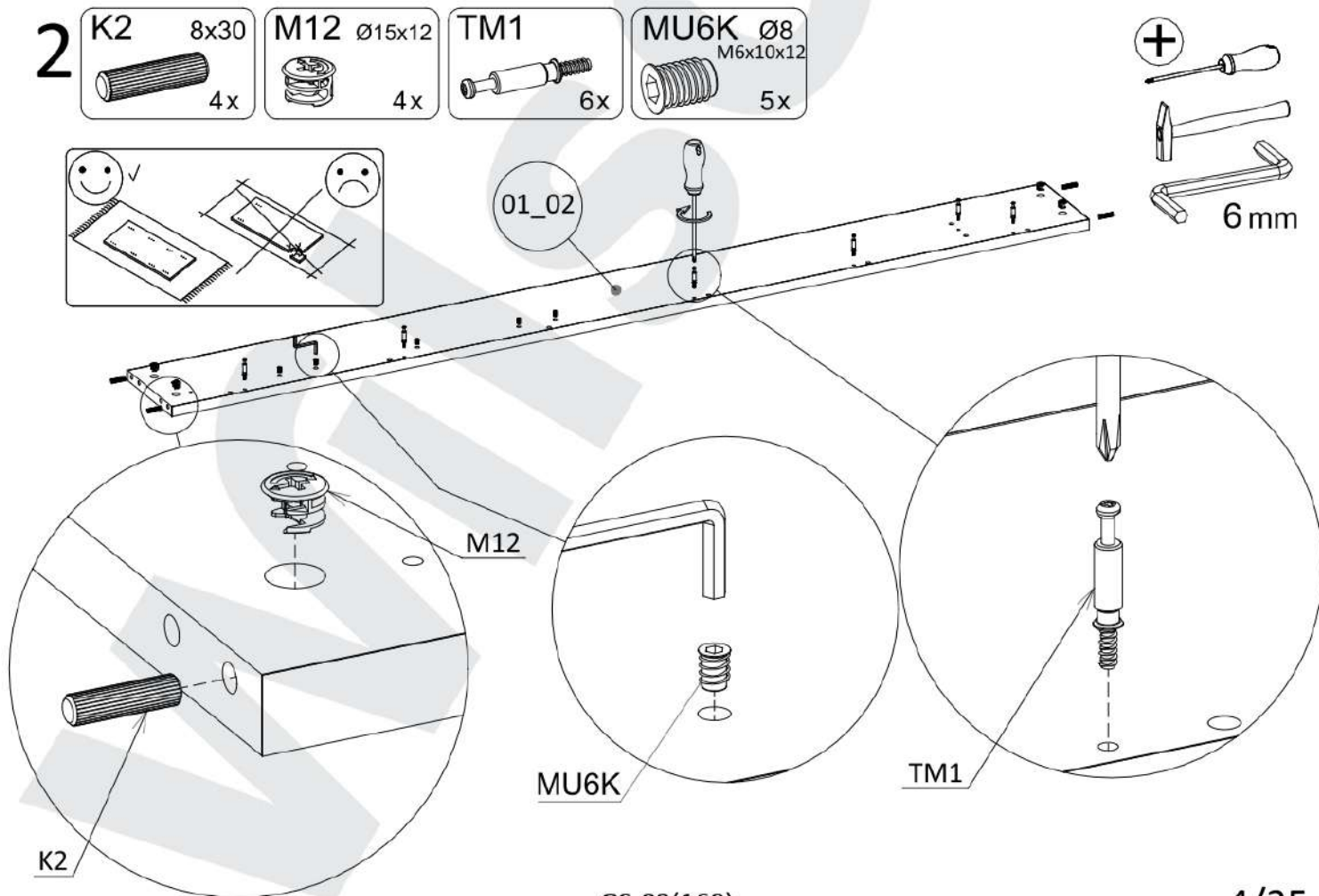
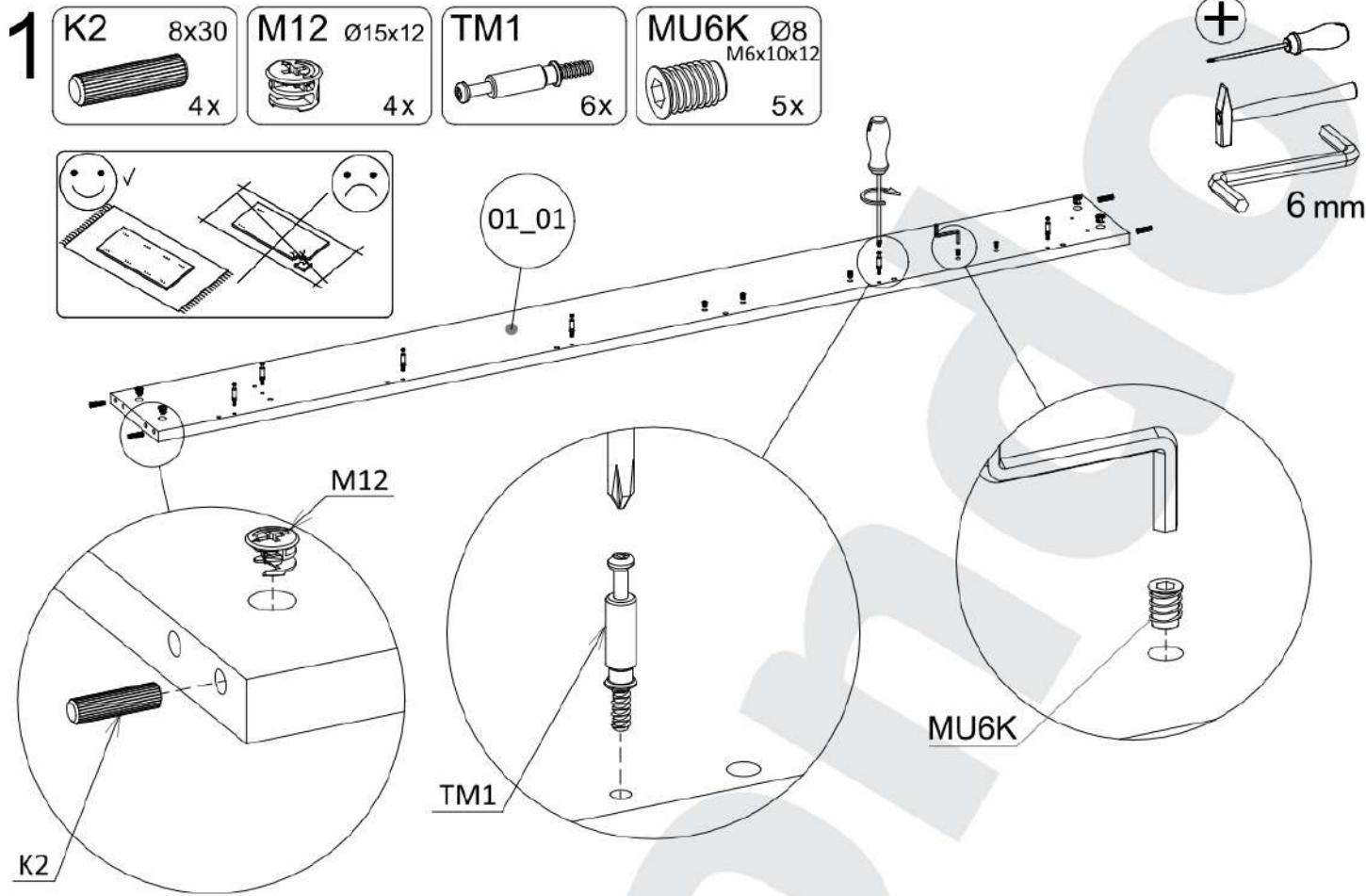

- 3**
- K2** 8x30 2x
 - M12** Ø15x12 2x
 - SG** 4x

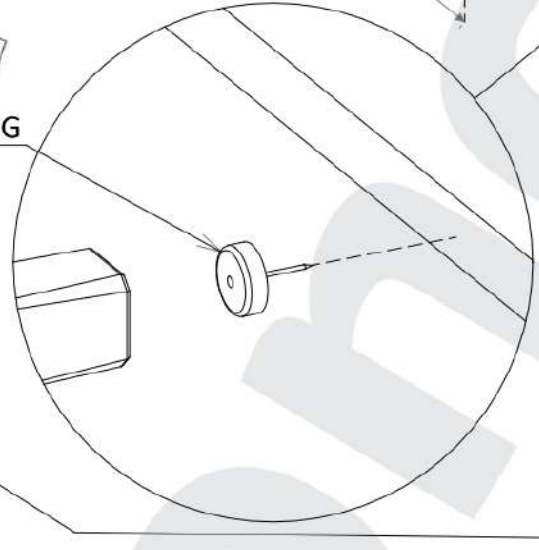
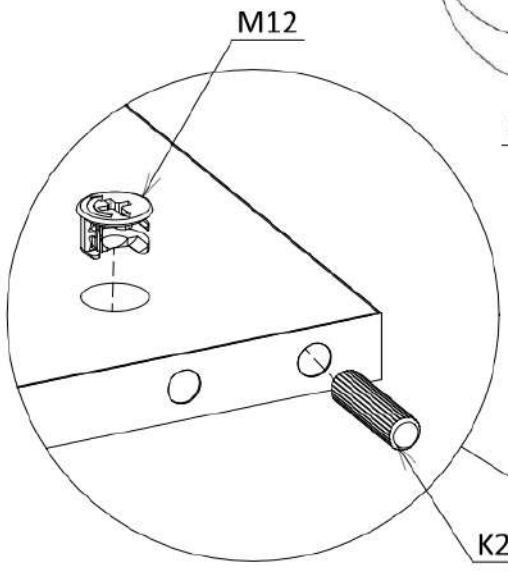
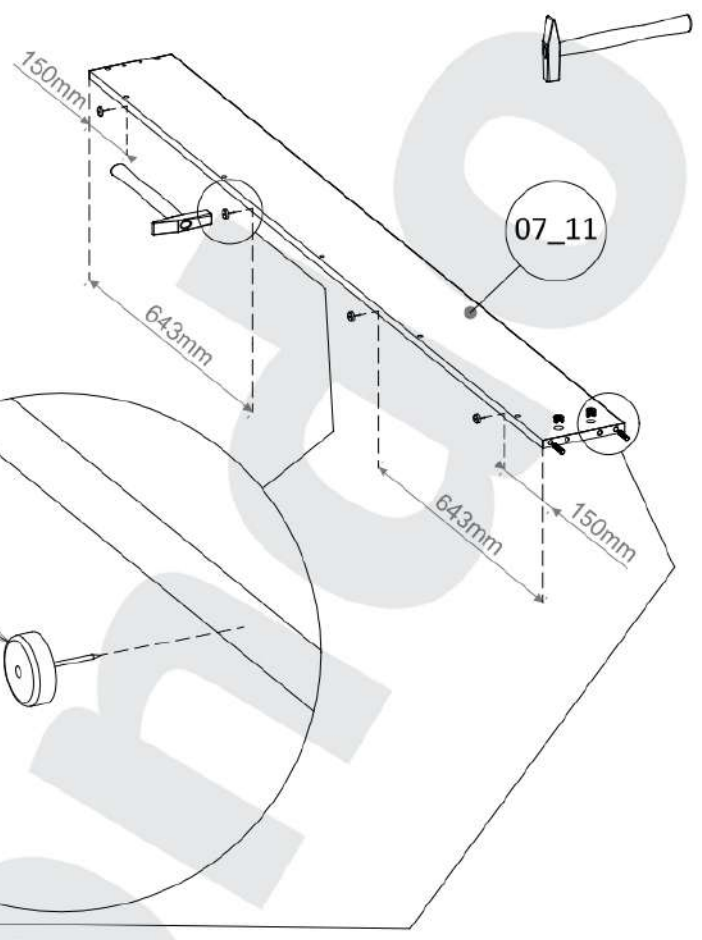
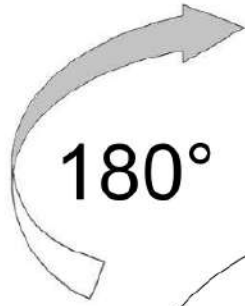
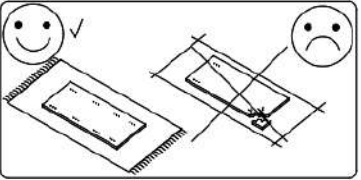

- 4**
- TM1** 5x

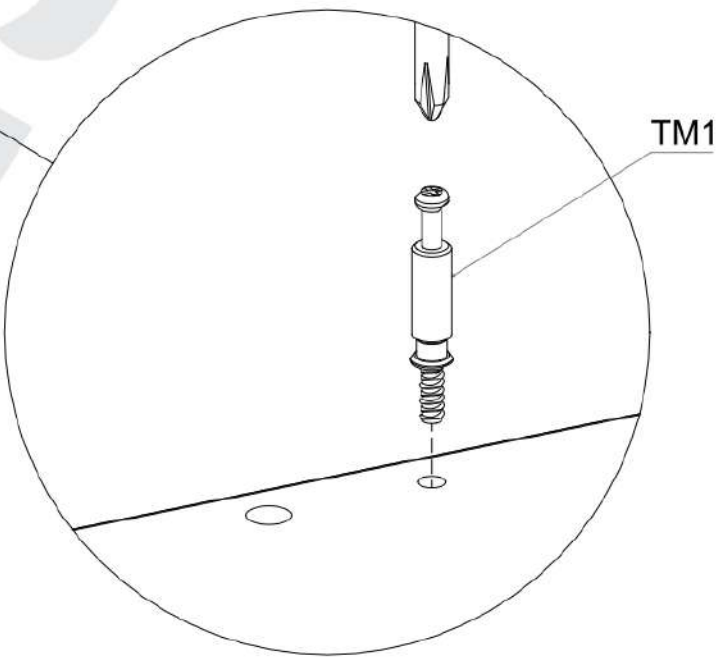
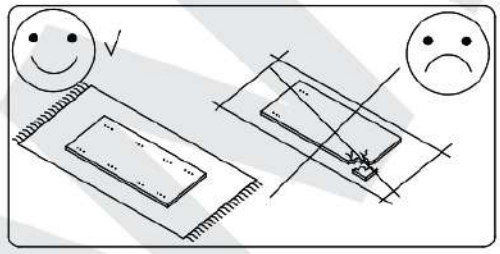
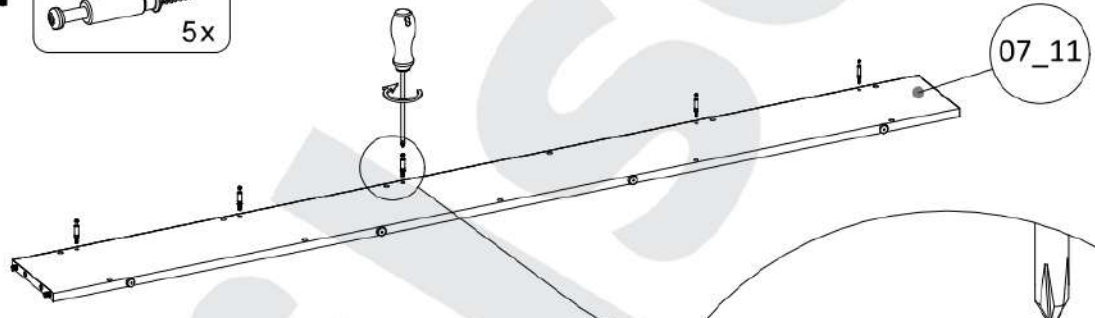
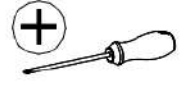

- 5** **K2** 8x30 2x **M12** Ø15x12 2x **SG** 4x

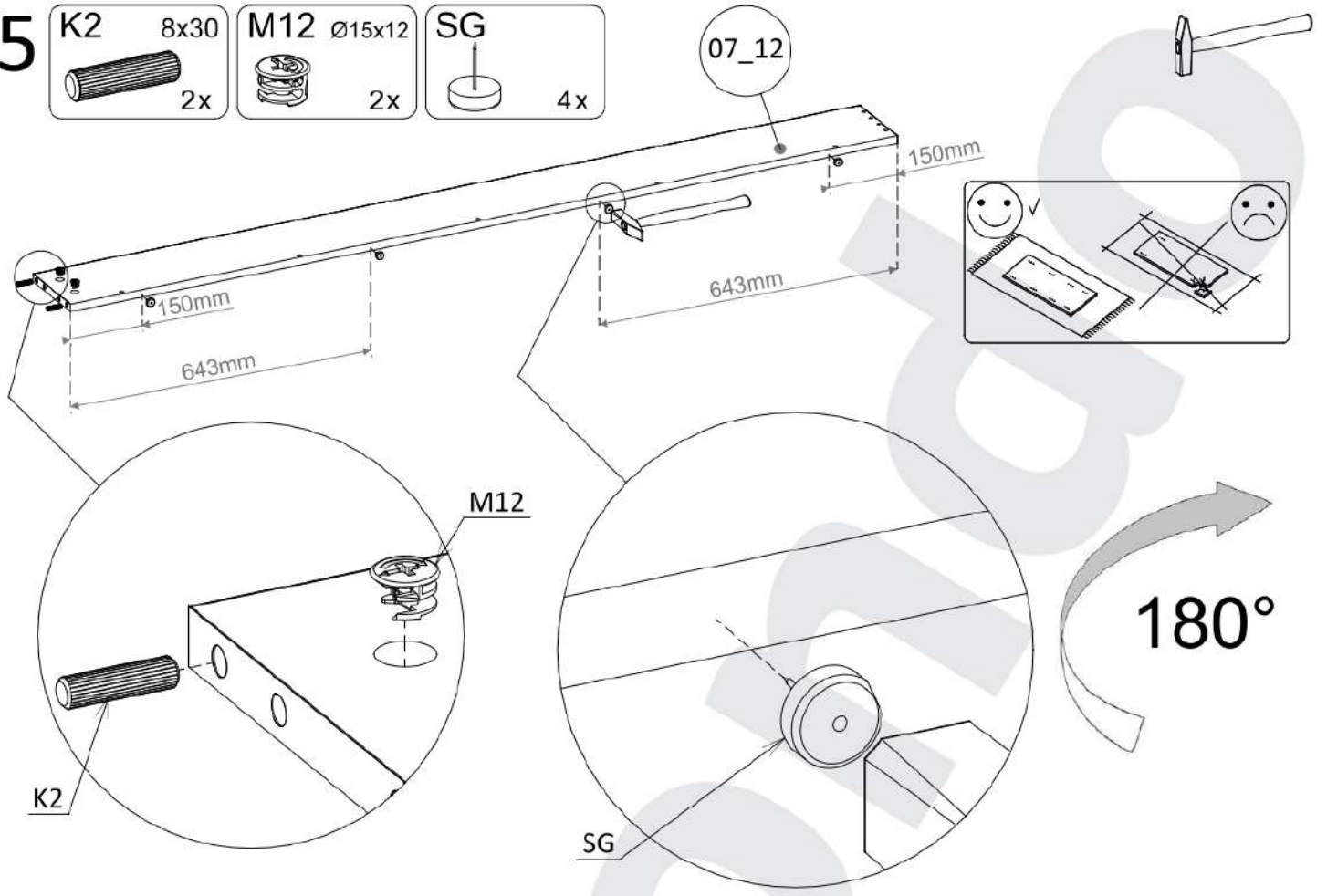

- 6** **TM1** 5x

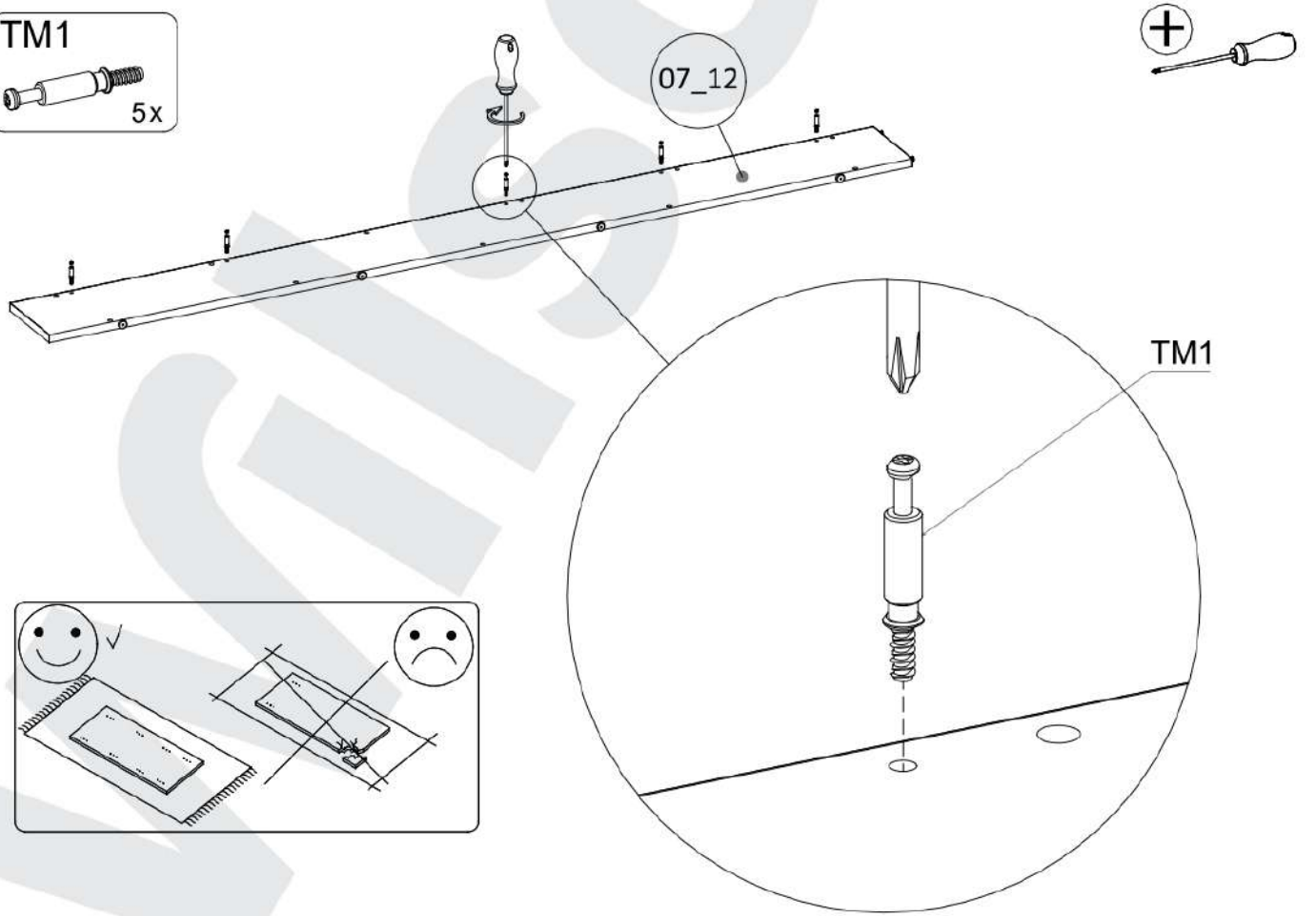

7

- K2** 8x30 4x
- M12** Ø15x12 4x
- SG** 3x

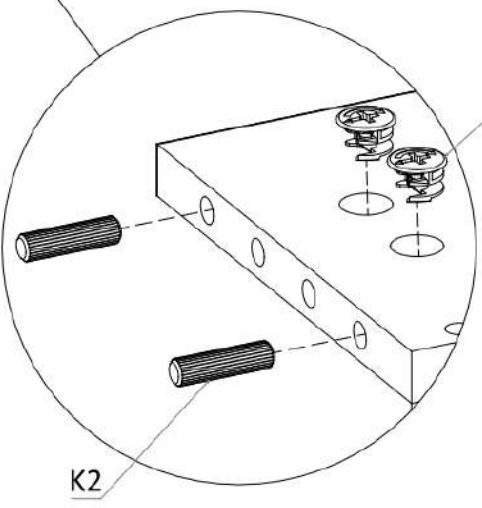
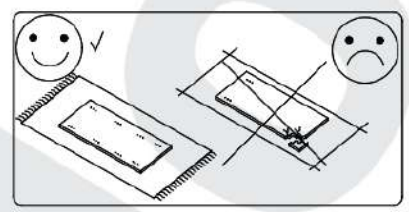
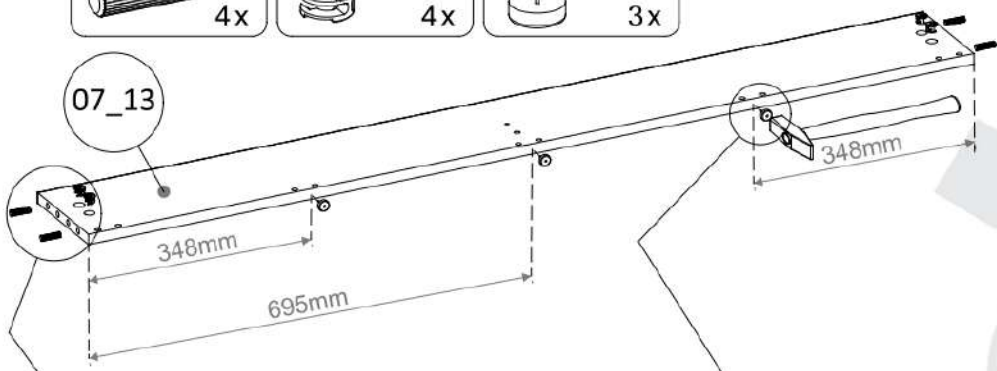

M12

K2

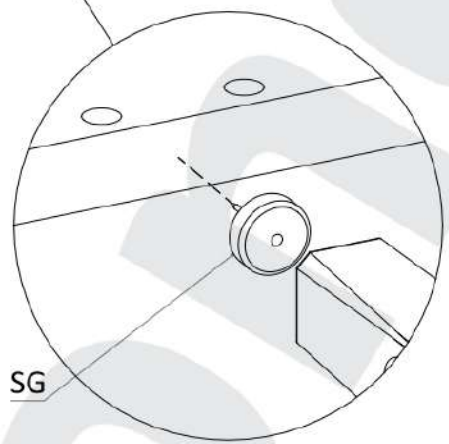

SG

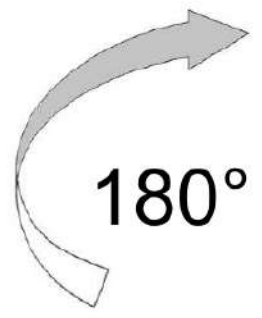

8

- TM1** 4x

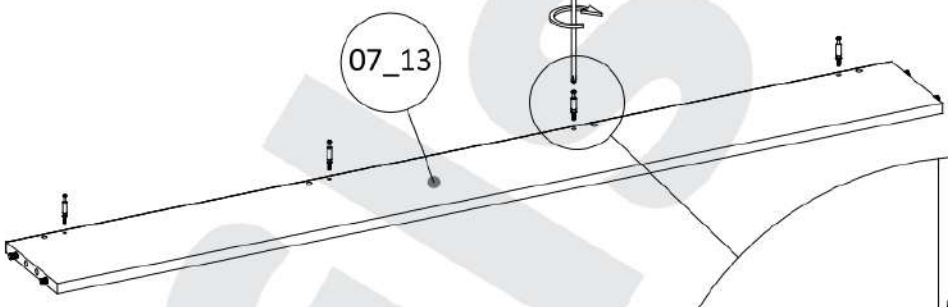

07_13

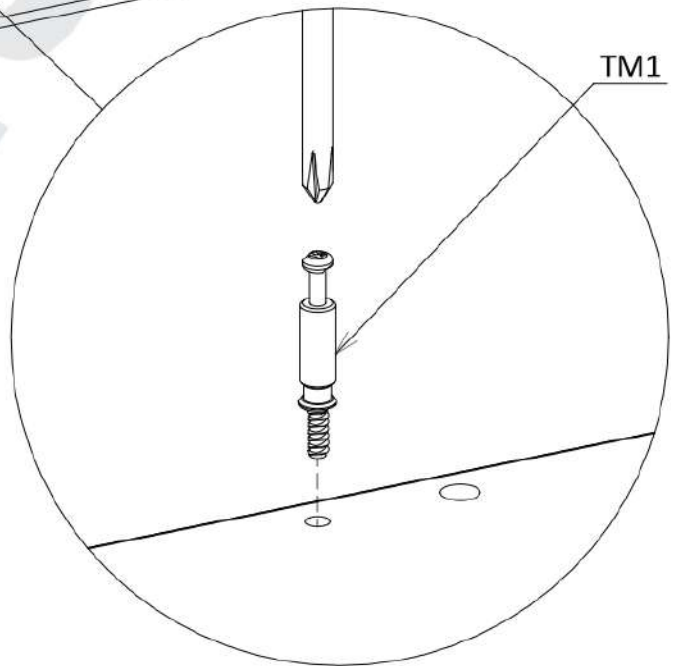
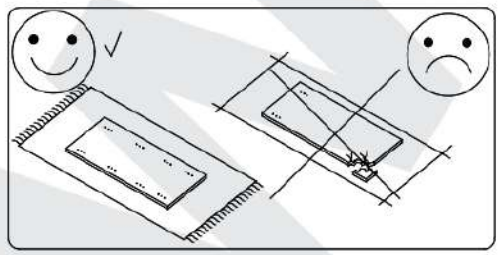

TM1

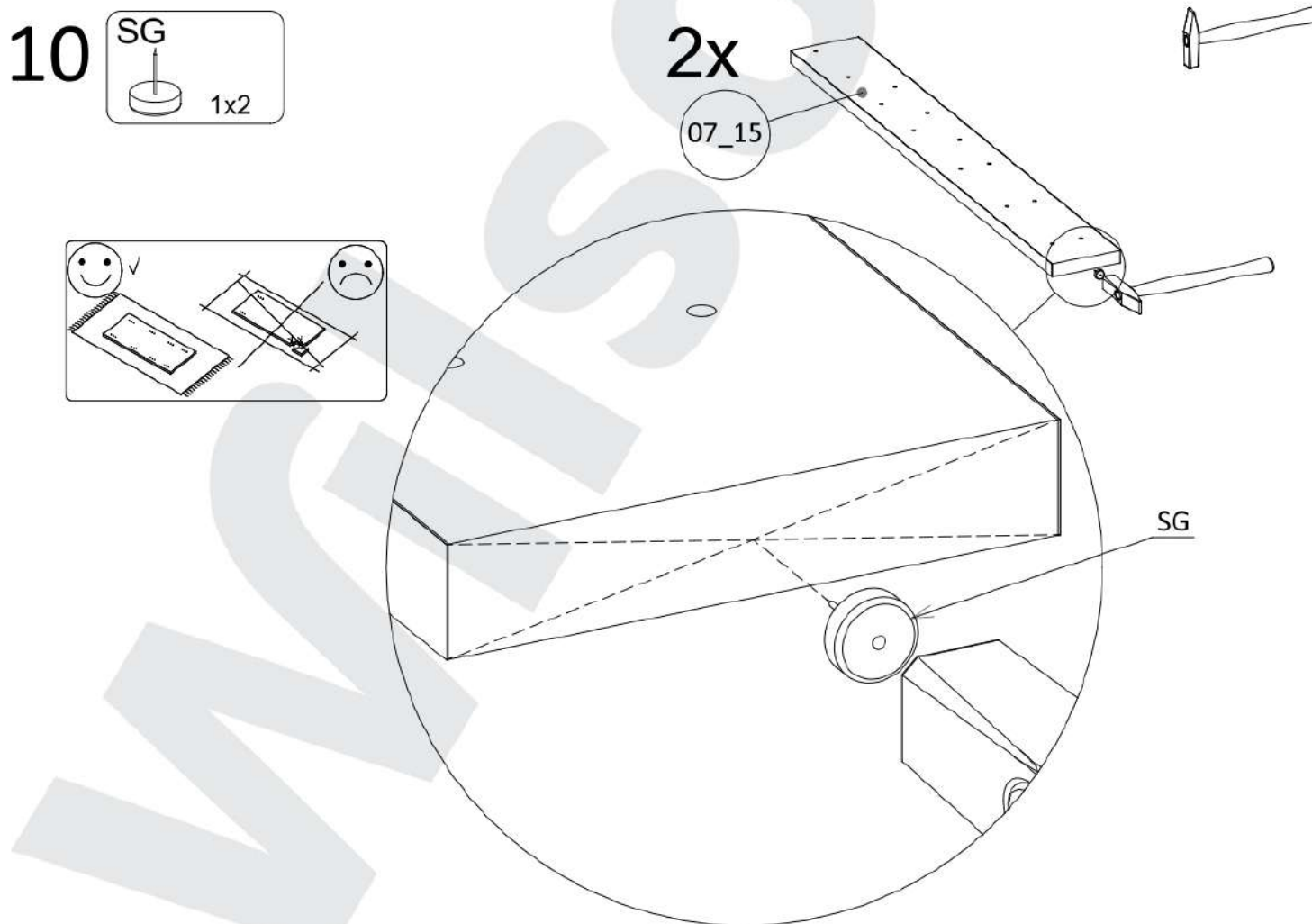
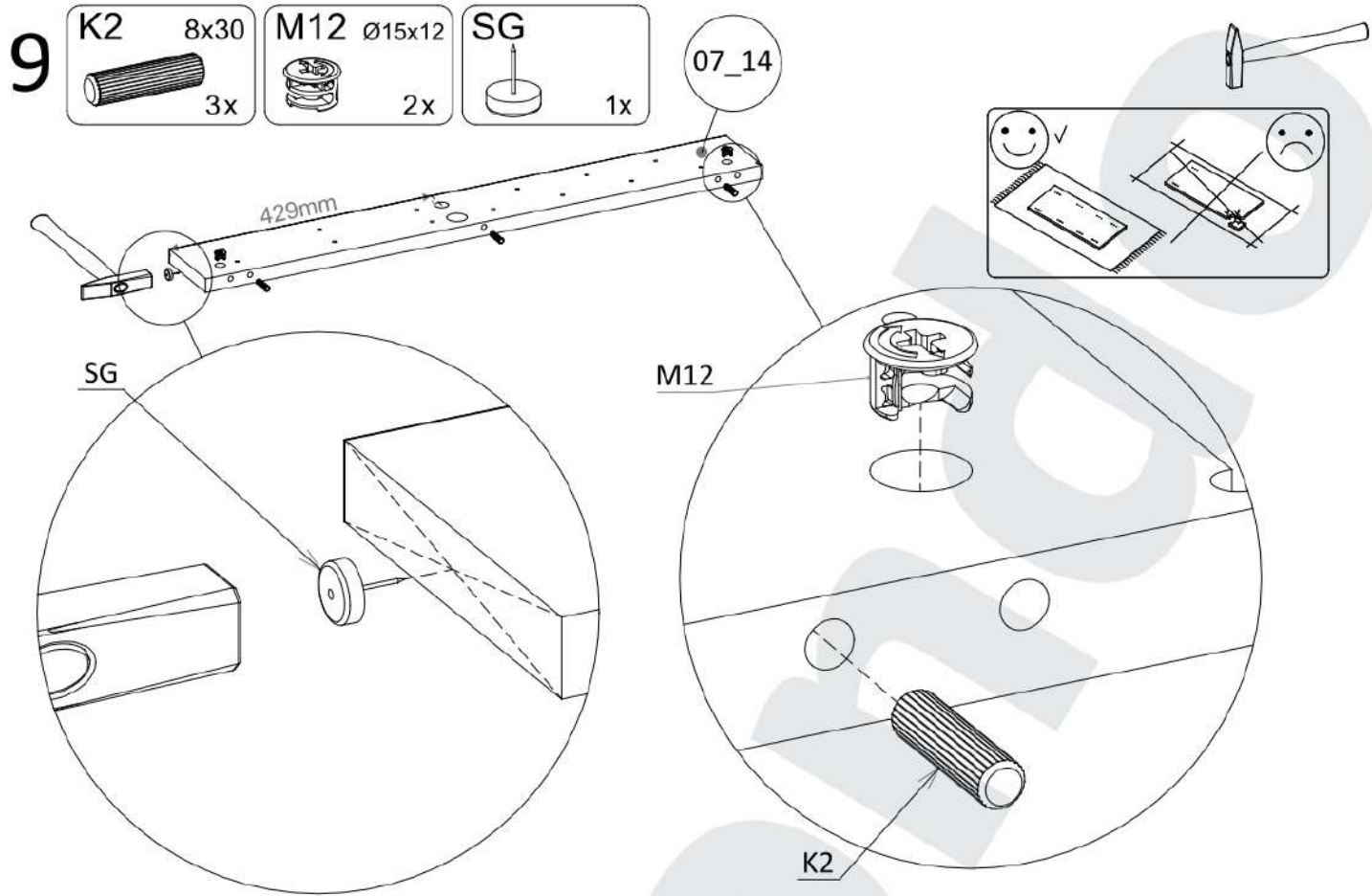

11

- K2** 8x30 3x
- M12** Ø15x12 2x
- SG** 1x

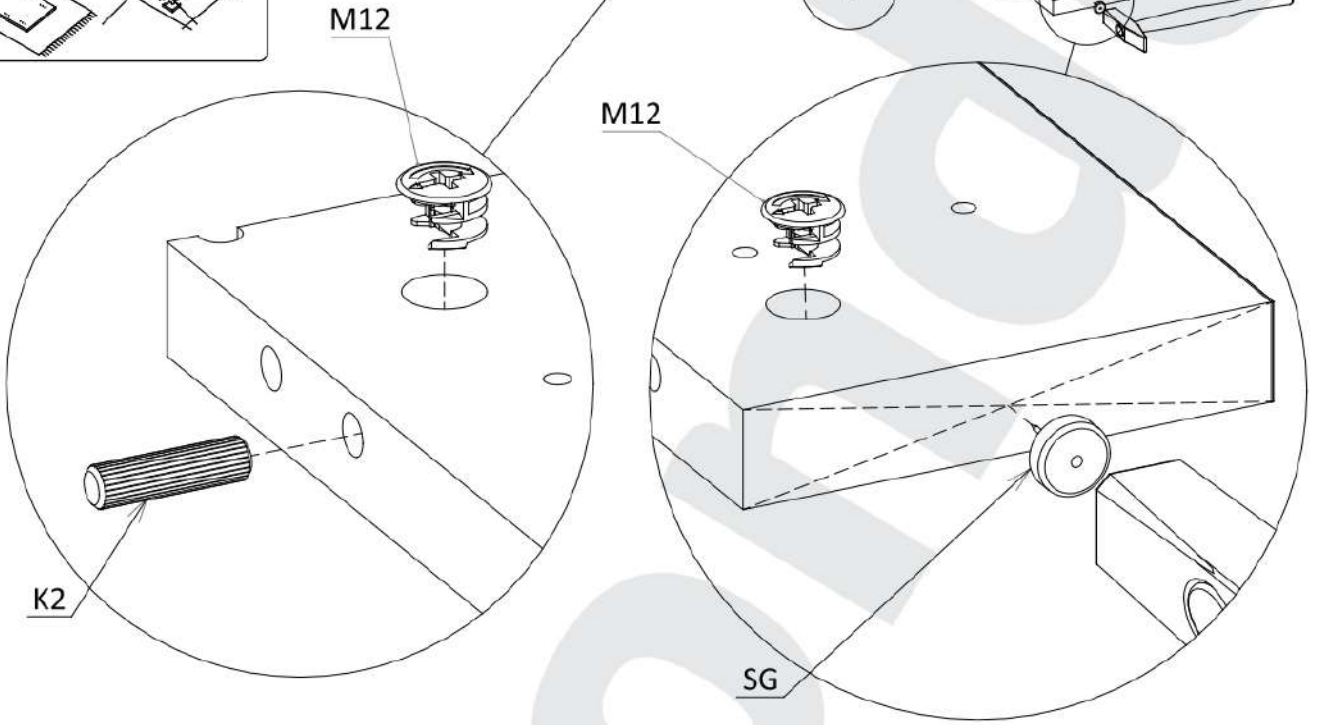
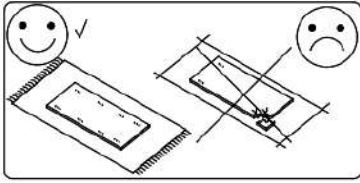

12

- K2** 8x30 4x
- M12** Ø15x12 4x

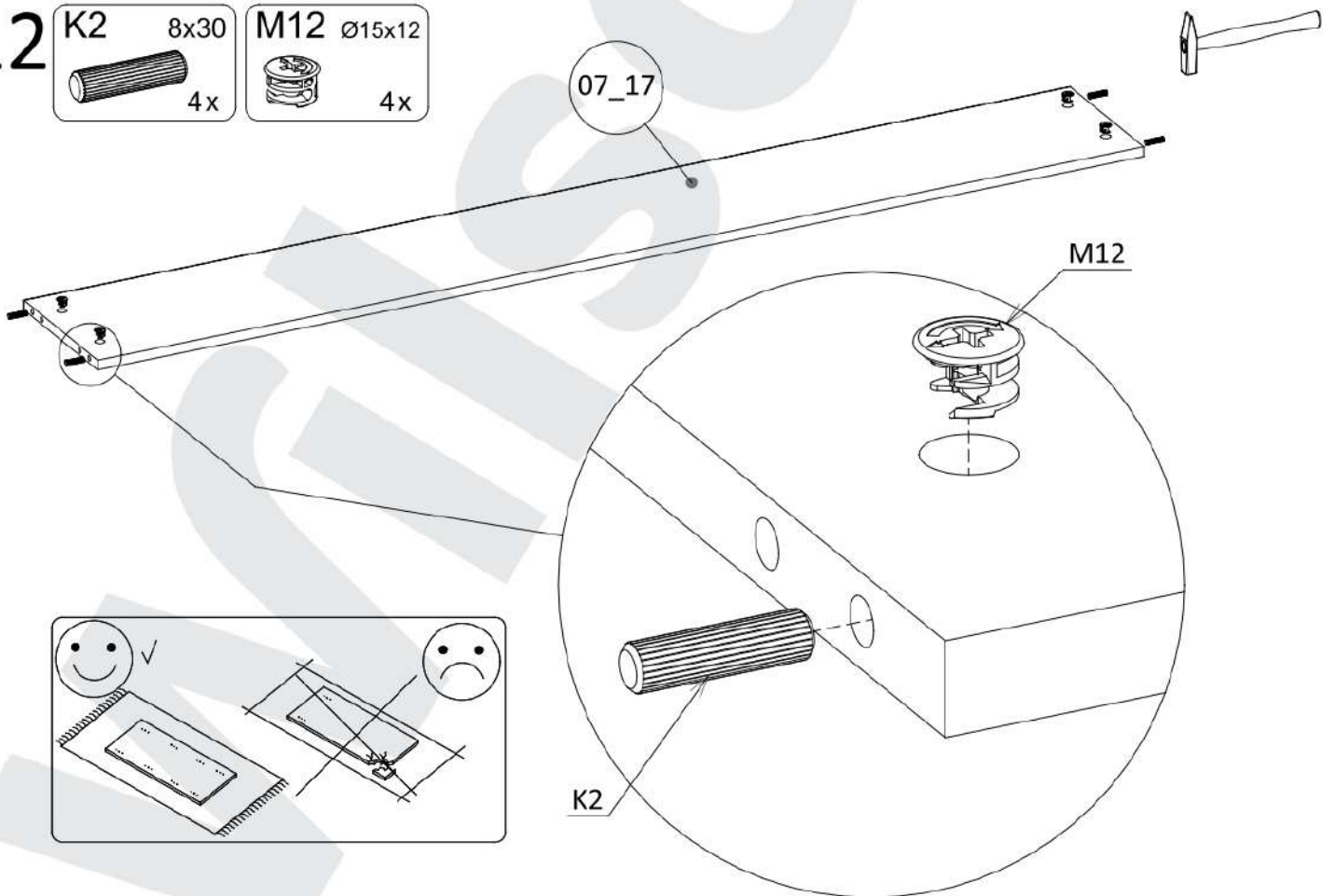
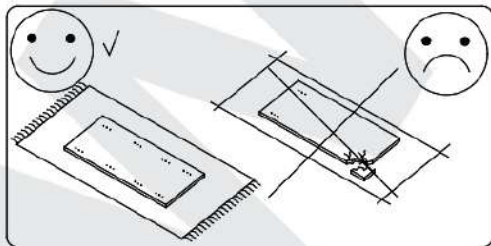

13

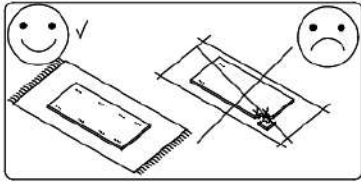
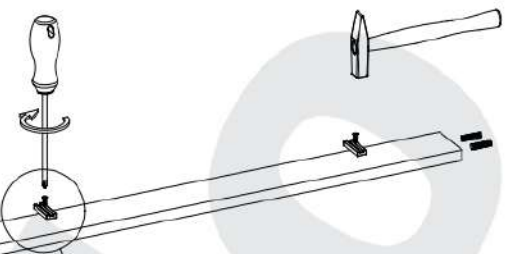
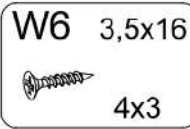
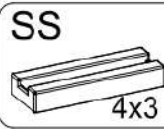
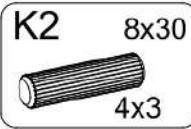

3x 07_31

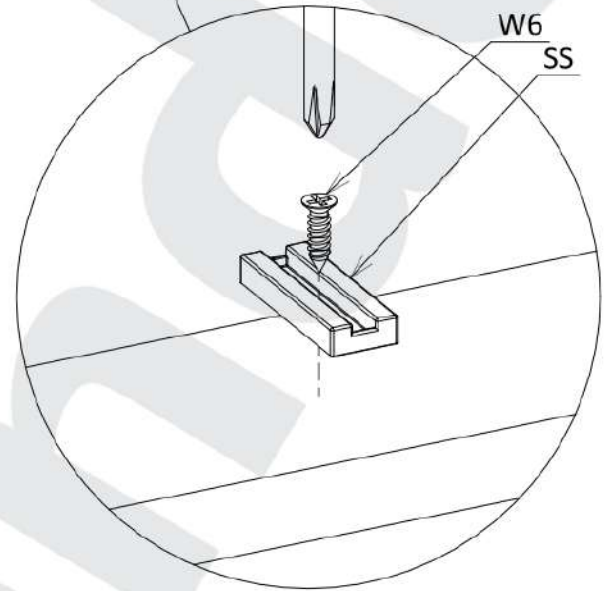
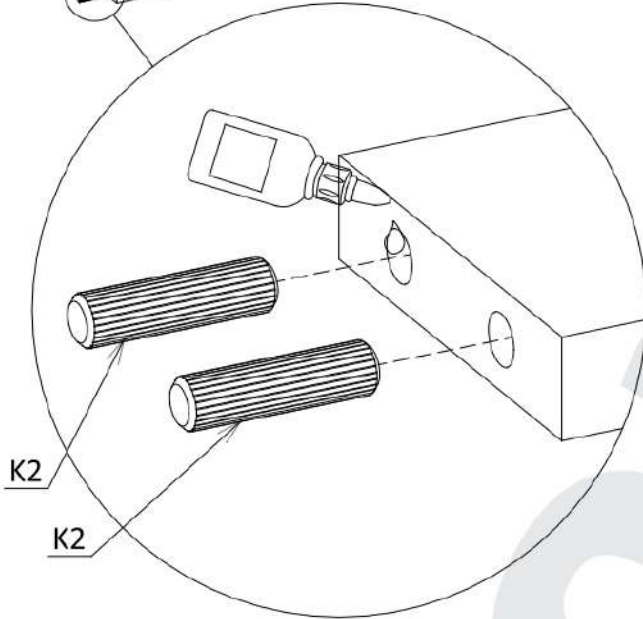

14

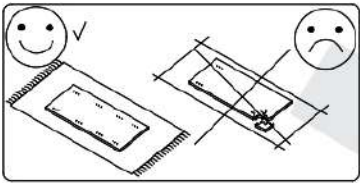
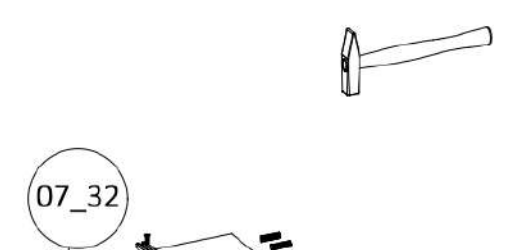
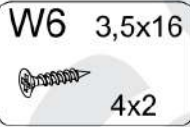
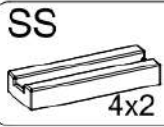
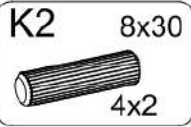

2x

07_32

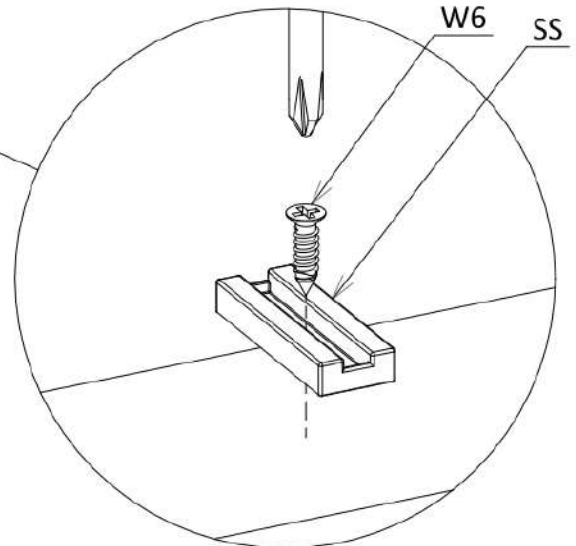
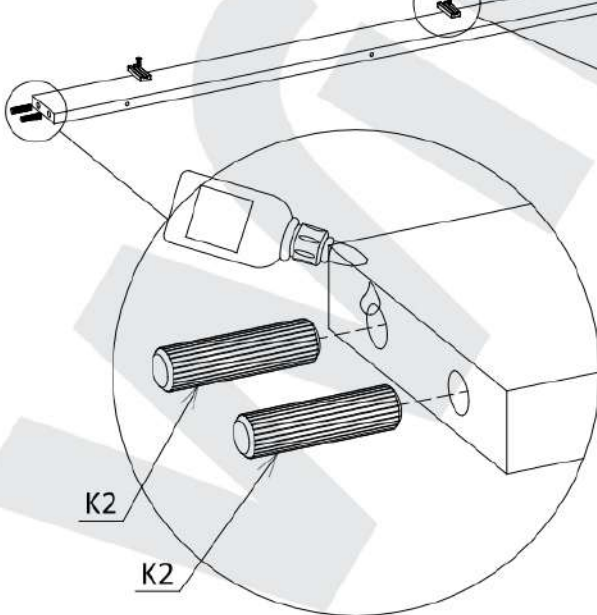

15

K2 8x30
16x

M12 Ø15x12
10x

TM1
2x

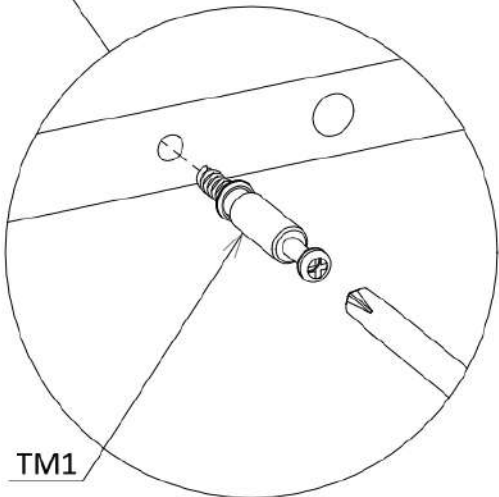
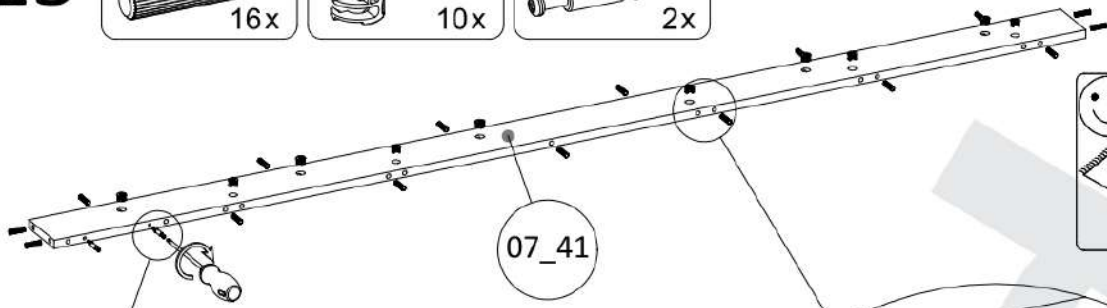
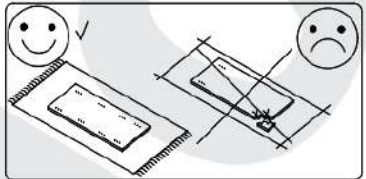
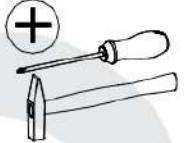

M12

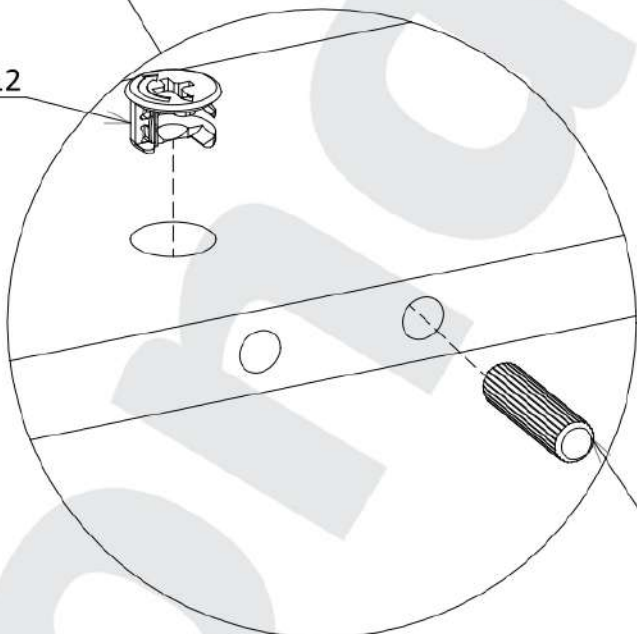

K2

16

K2 8x30
12x

M12 Ø15x12
12x

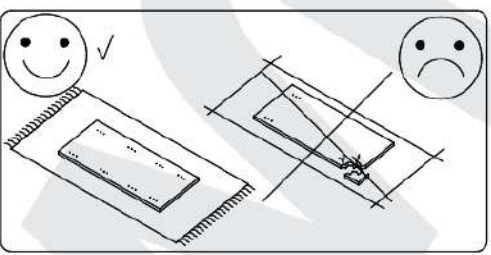
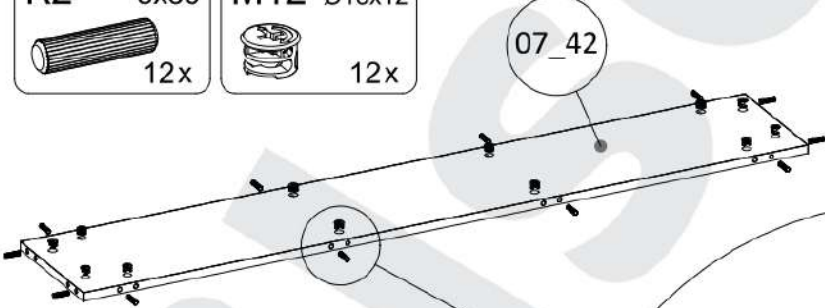

M12

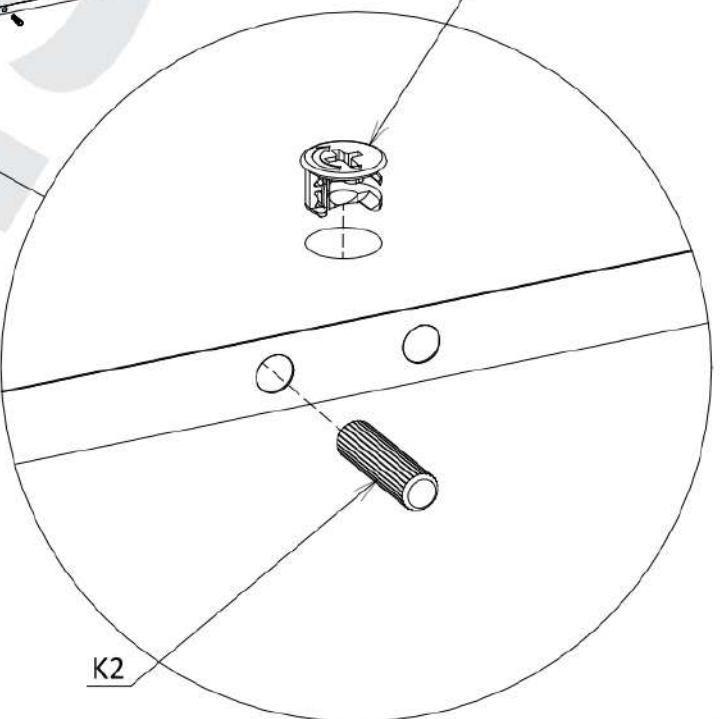

K2

17

K2 8x30
16x

M12 Ø15x12
10x

TM1
2x

07_43

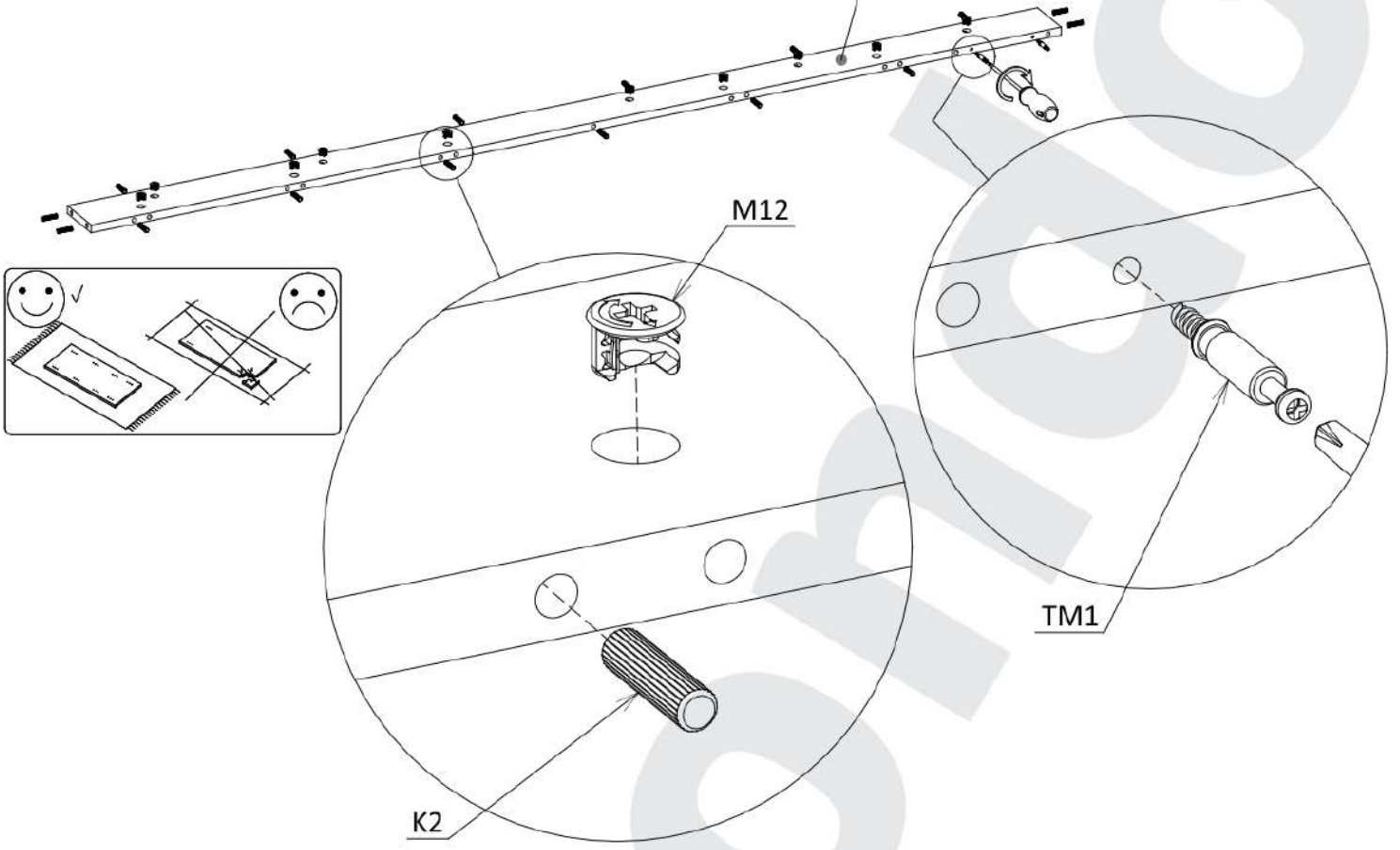
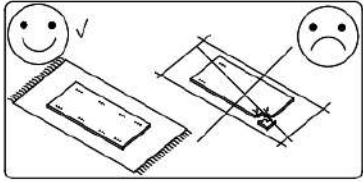
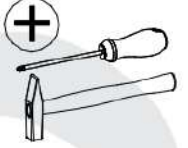

18

K2 8x30
7x

M12 Ø15x12
2x

07_61

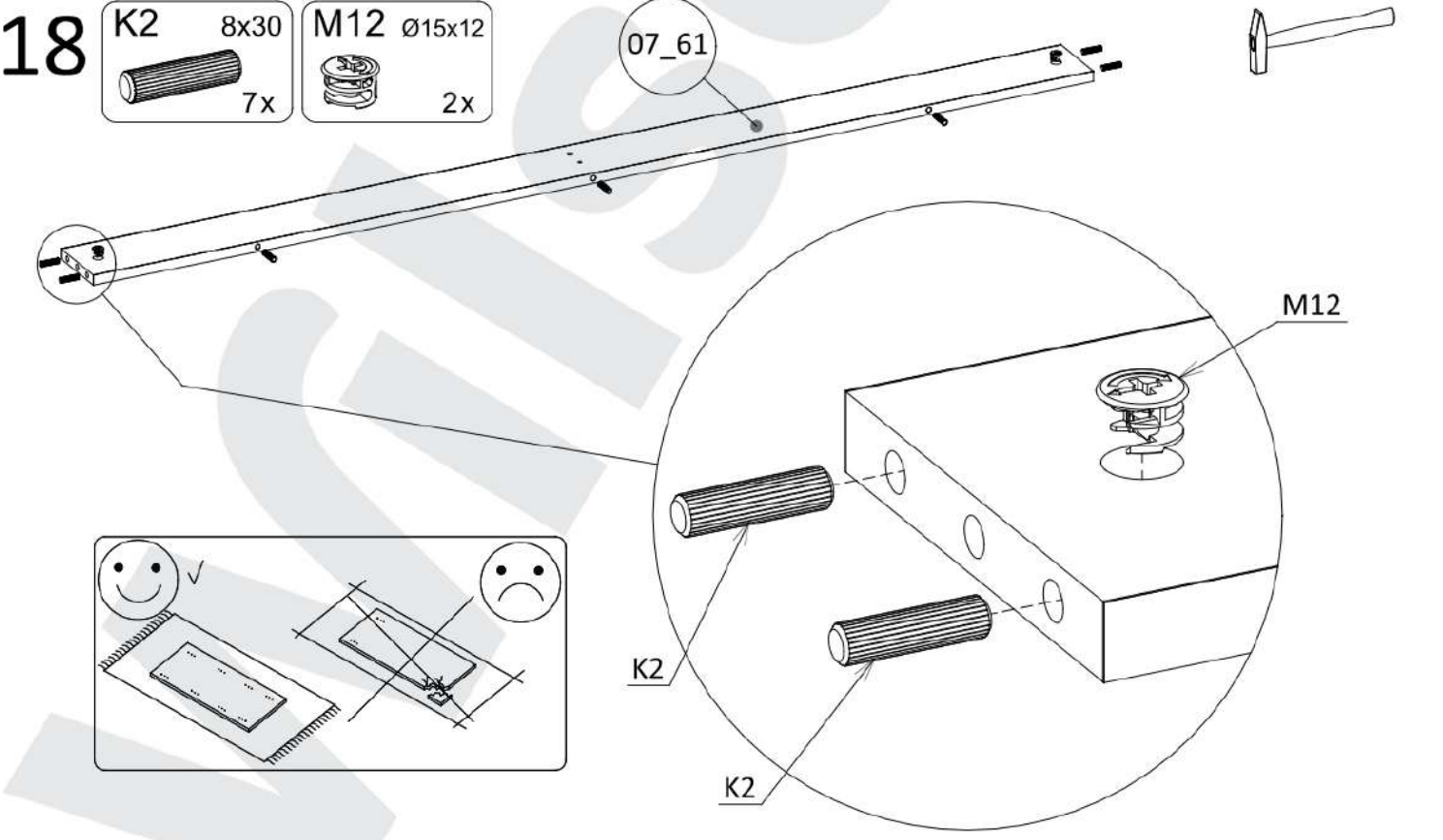
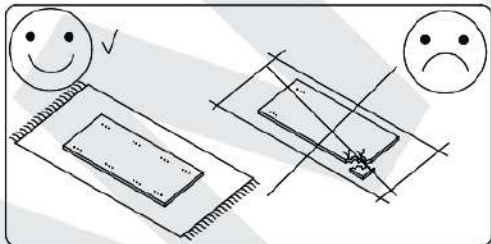

19

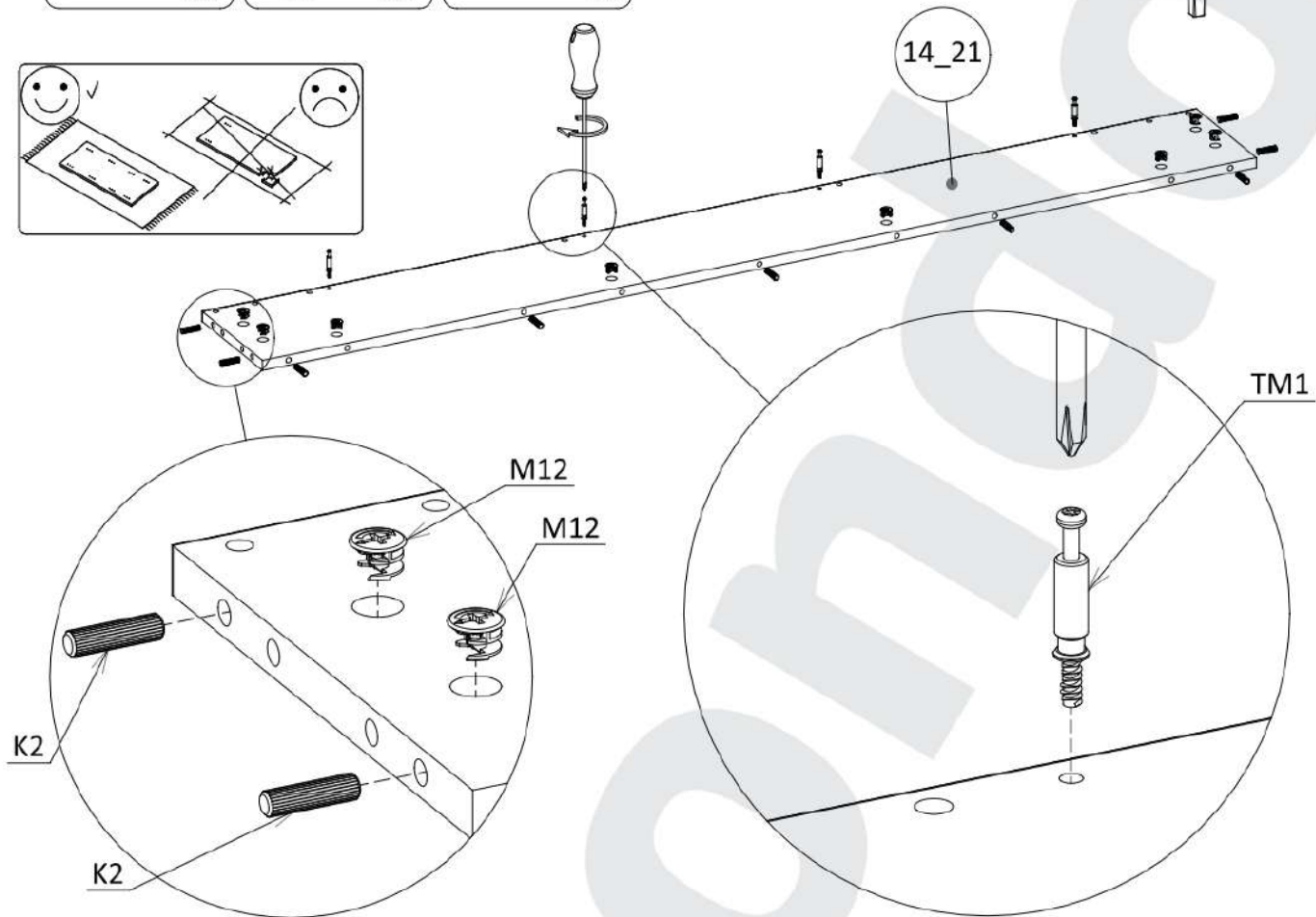
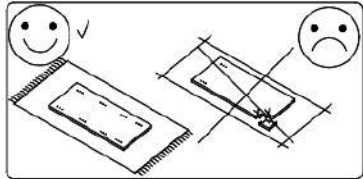
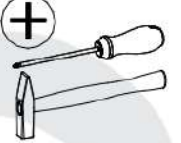
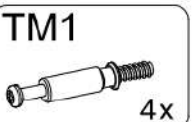
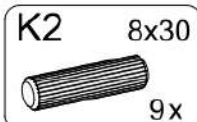

20

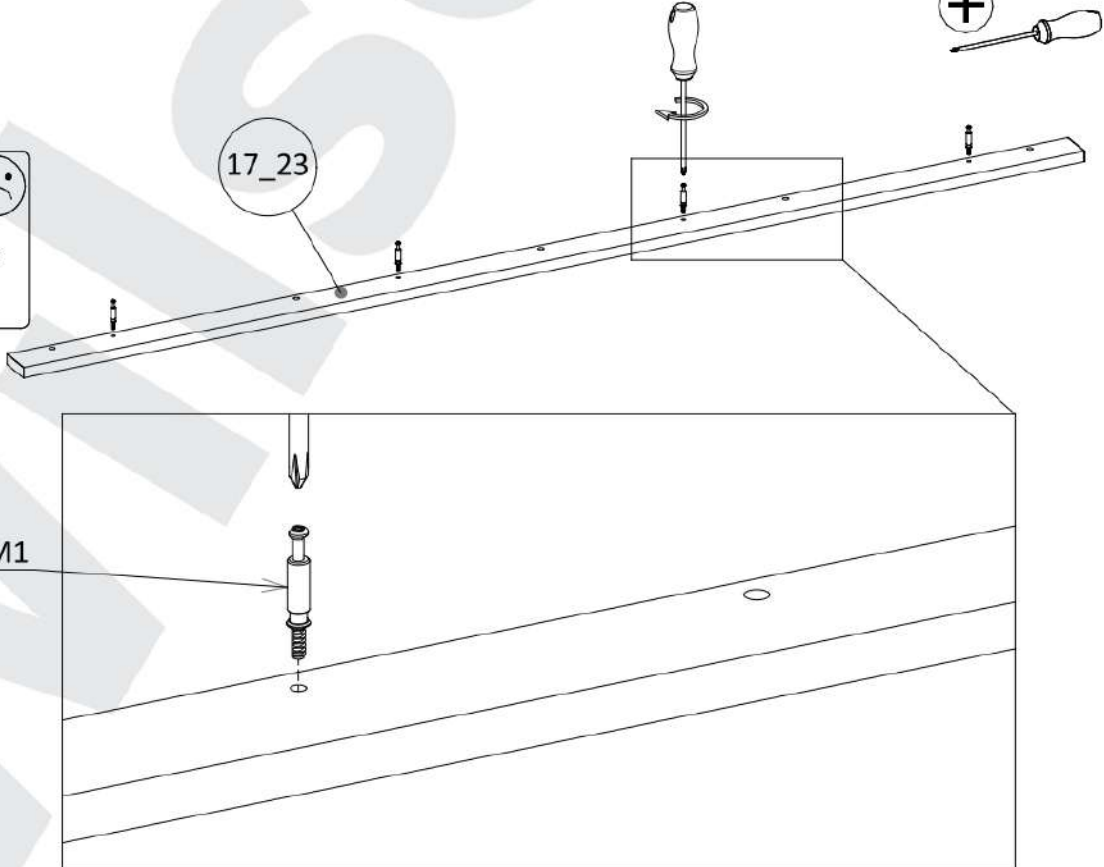
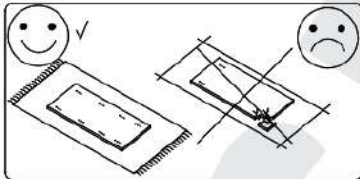
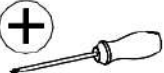
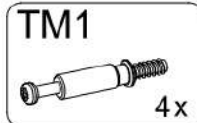

21

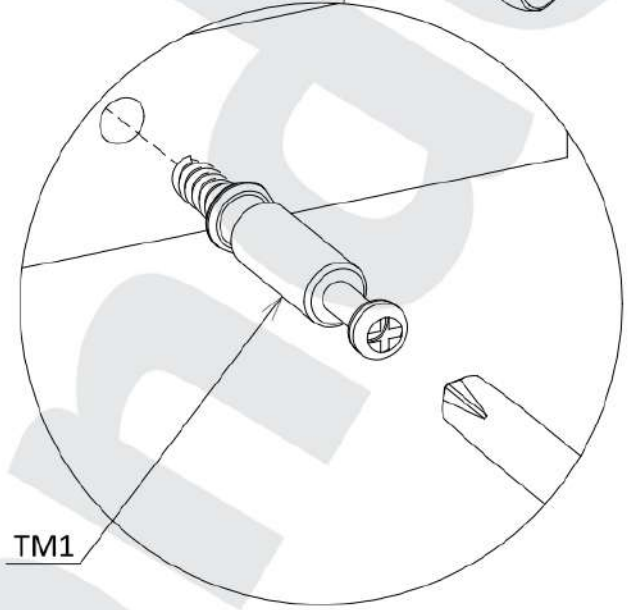
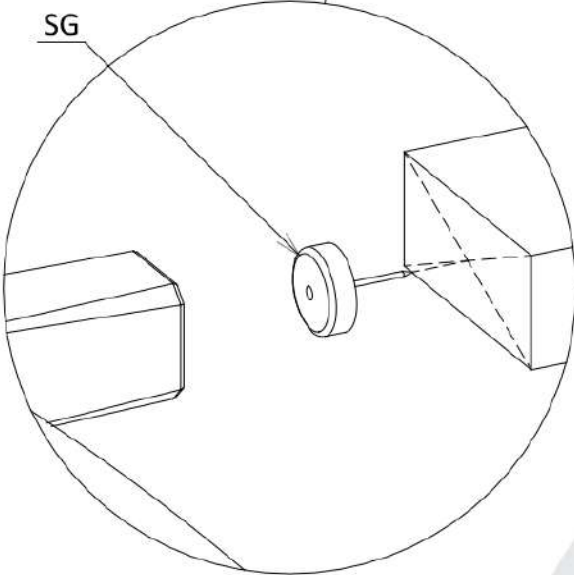
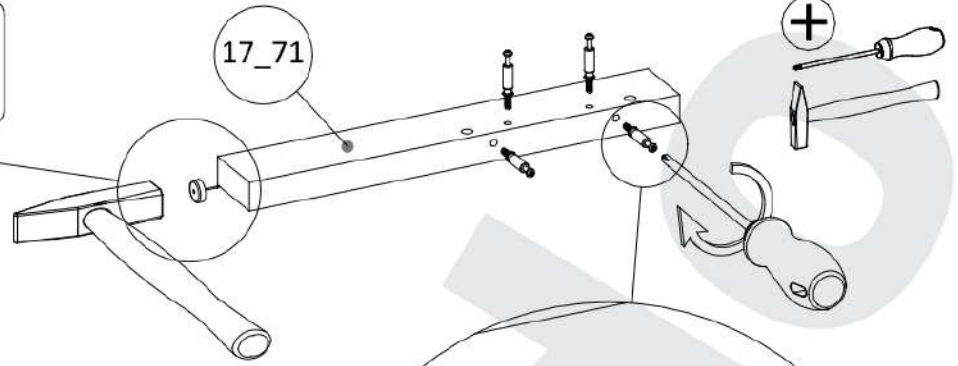
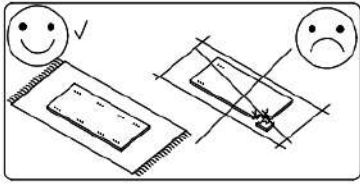
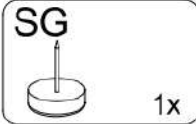
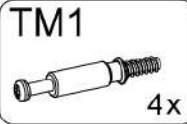

22

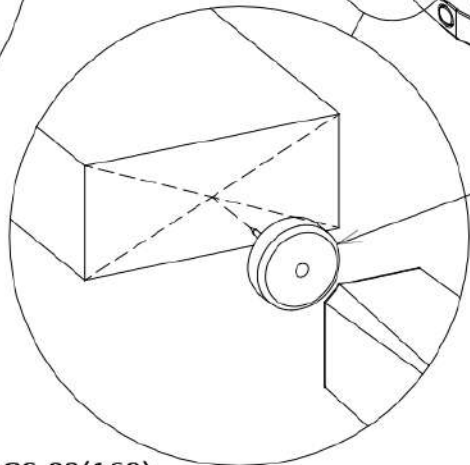
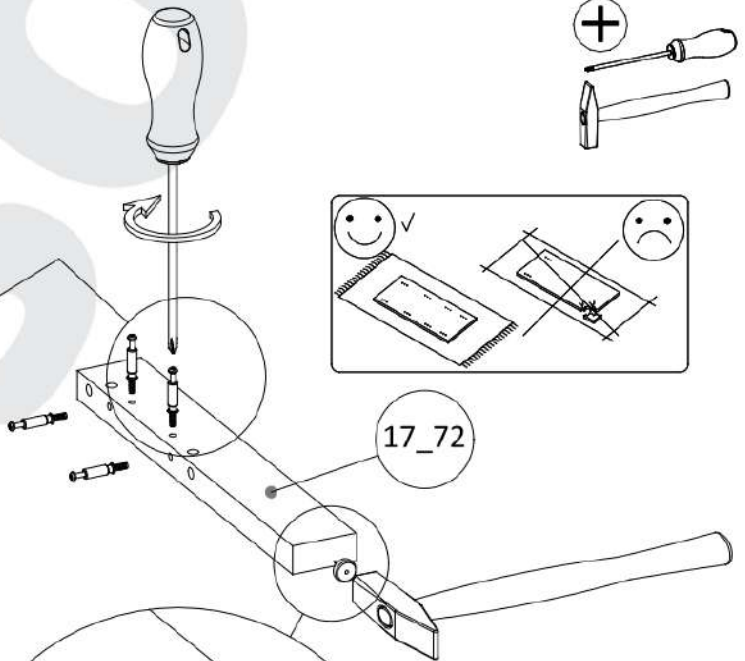
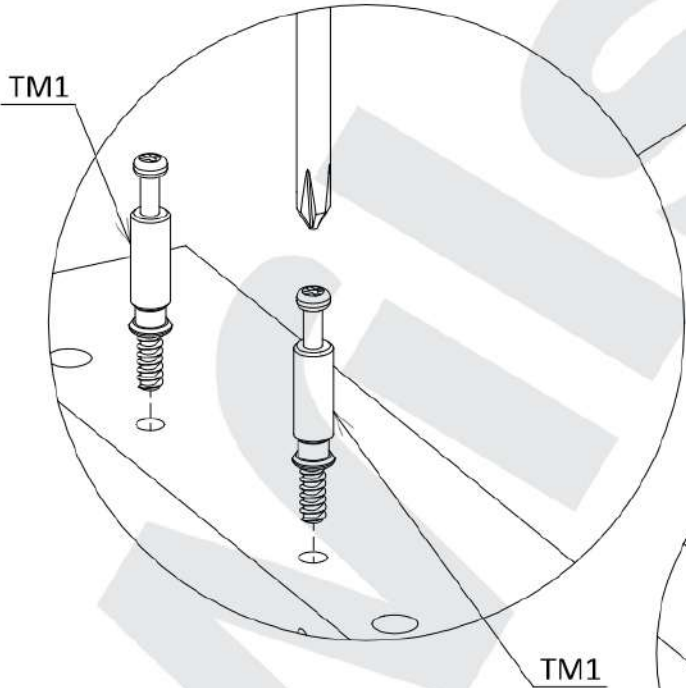
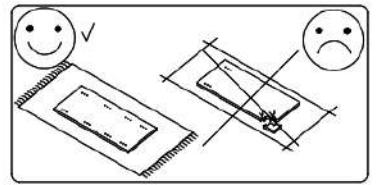
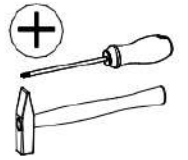
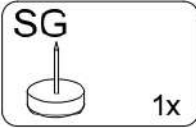
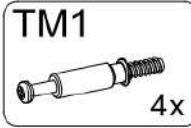

23

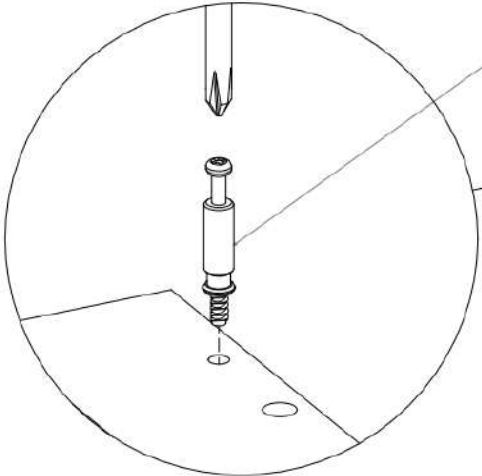
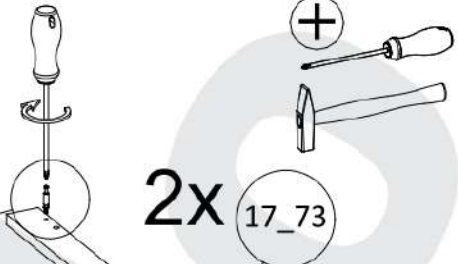
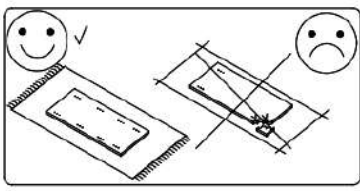
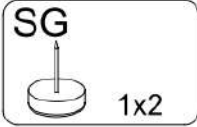
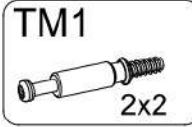

TM1

2x 17_73

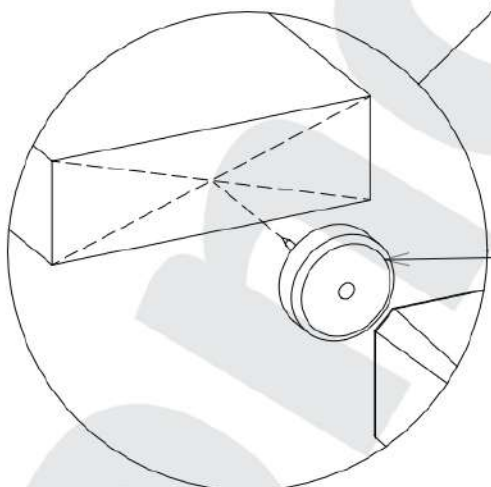

SG

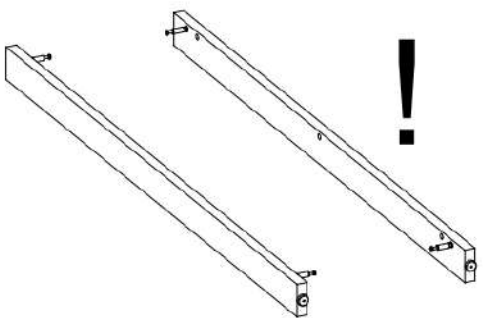

24

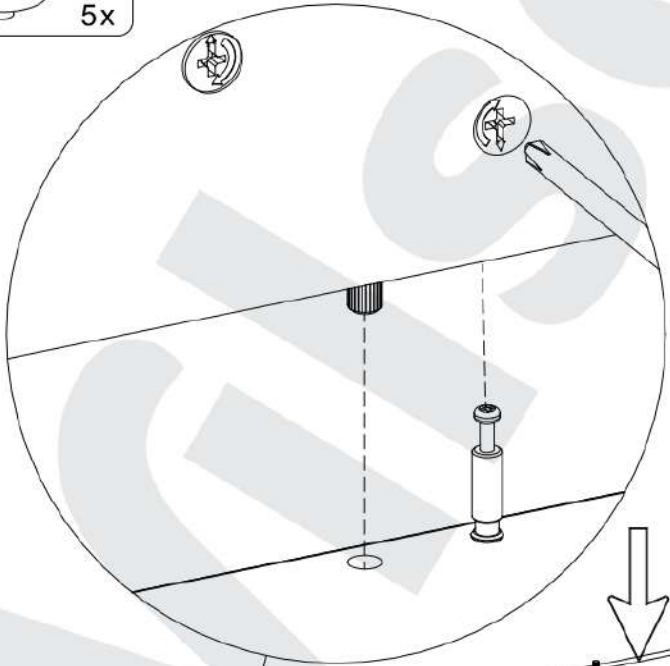
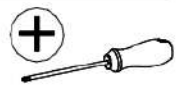
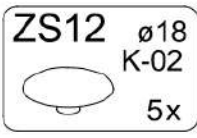

07_41

01_01

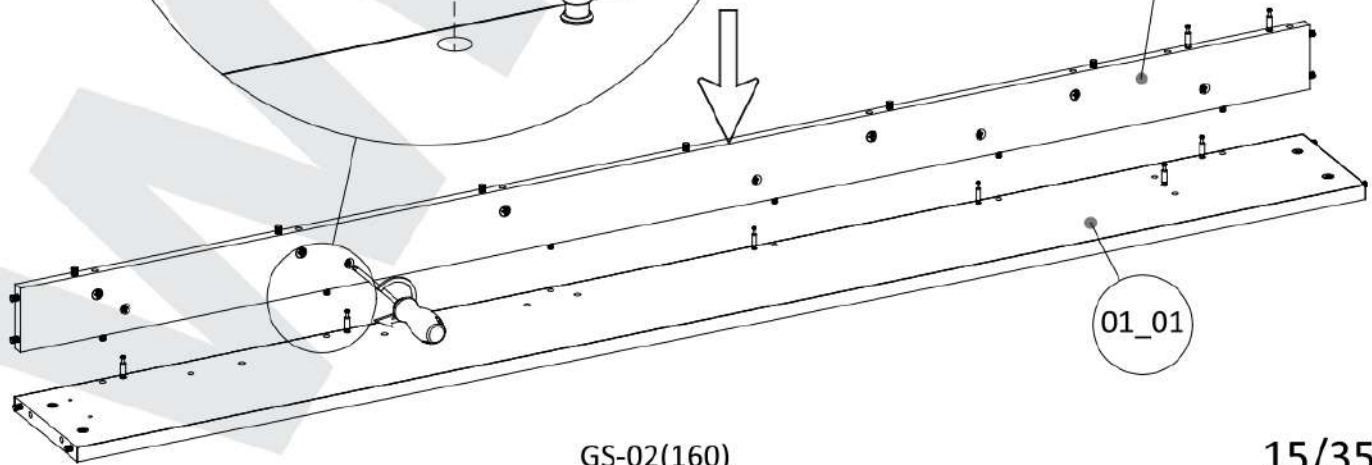

25

ZS12 $\phi 18$
K-02
5x

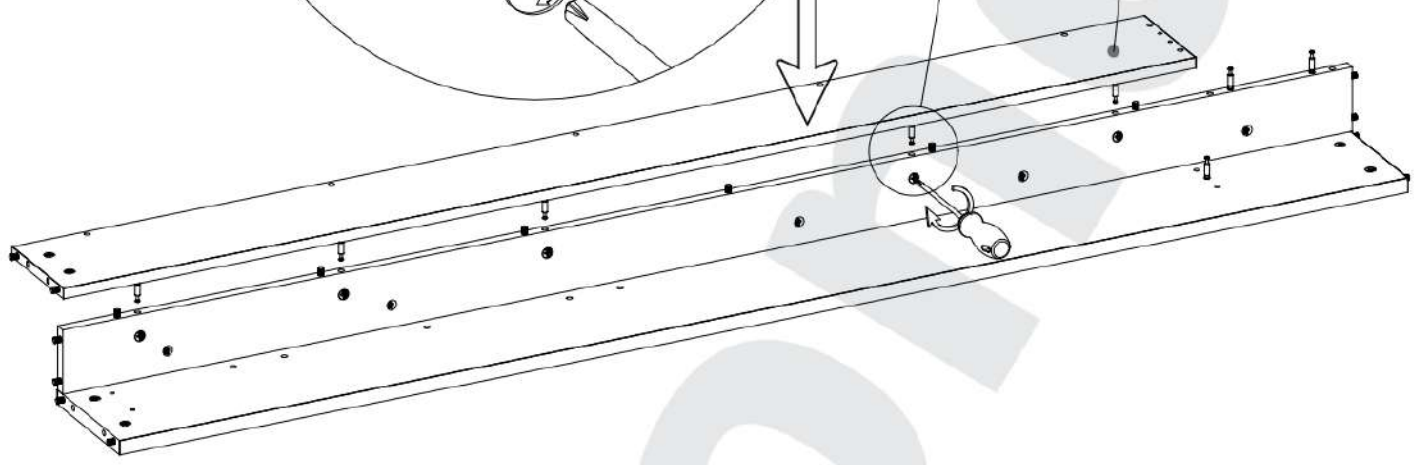
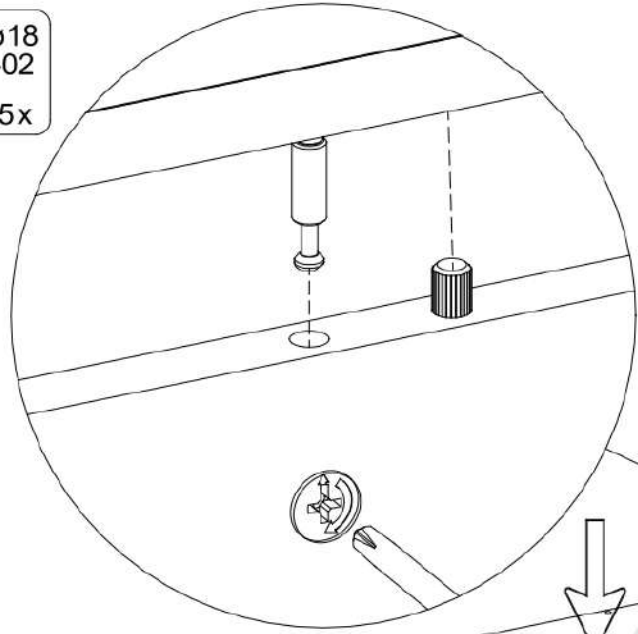

26

TM1
2x

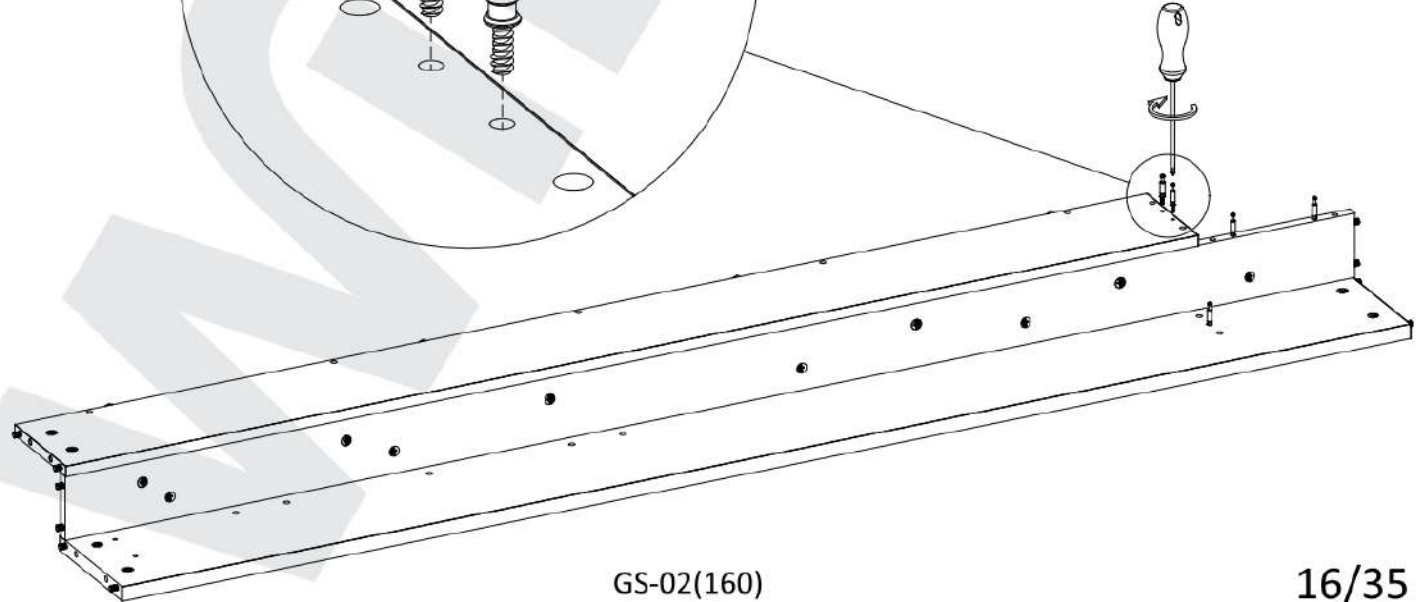
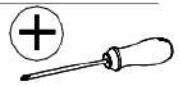
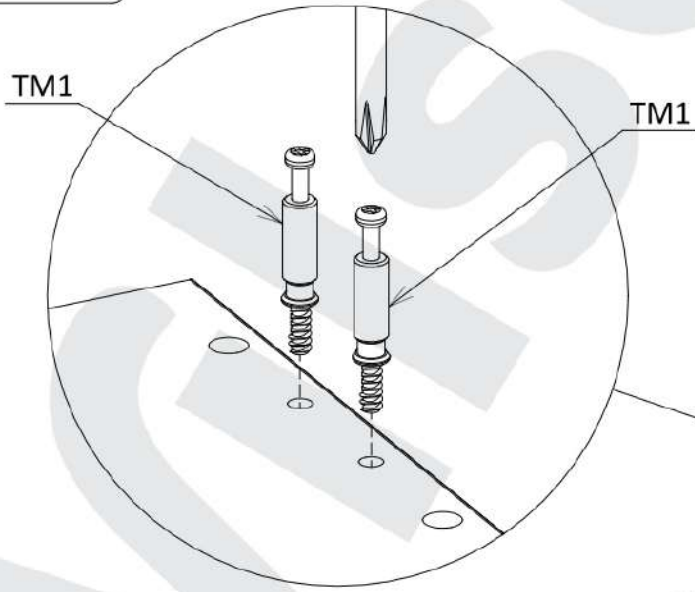

27

ZS12 $\varnothing 18$
K-02
5x

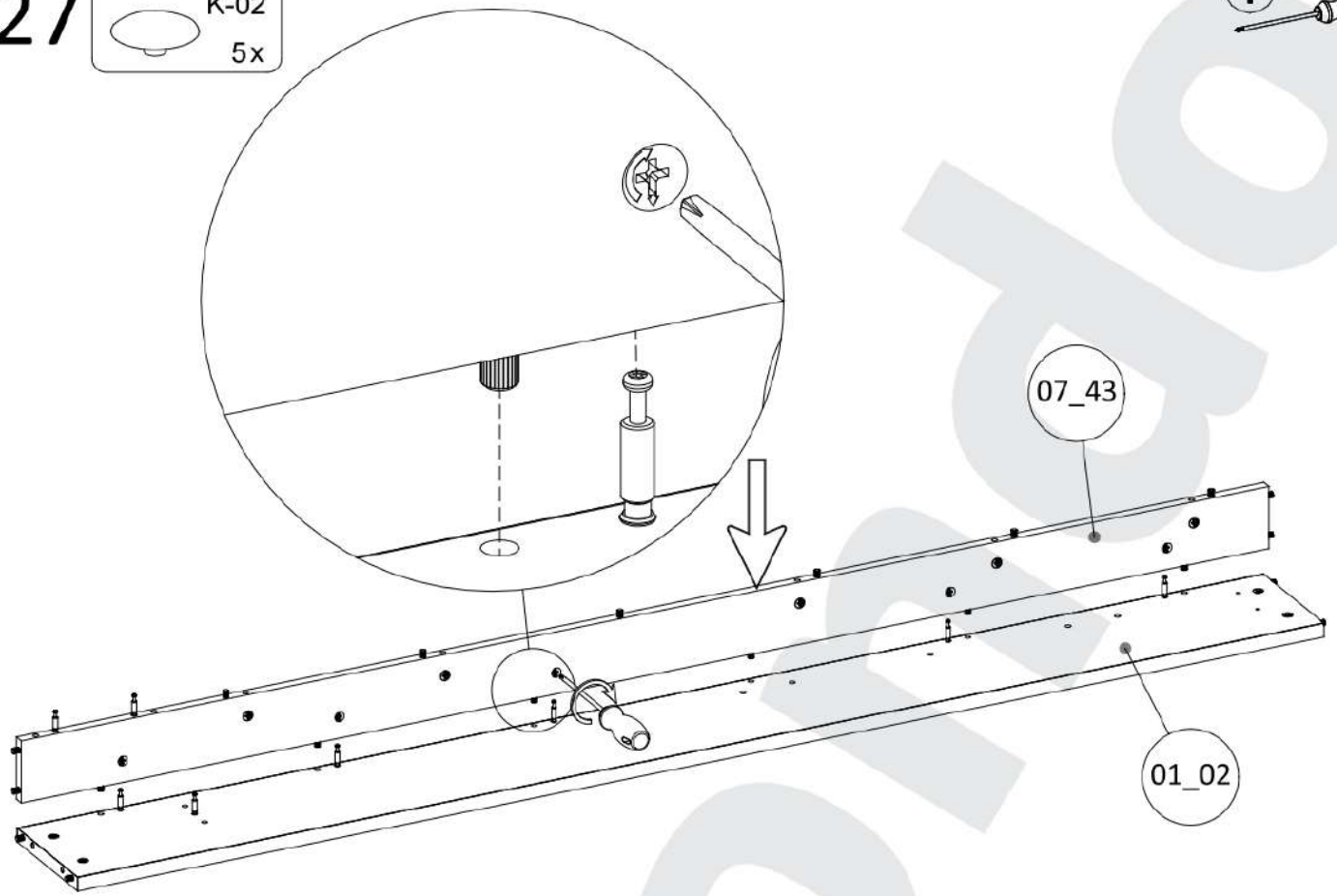

28

ZS12 $\varnothing 18$
K-02
5x

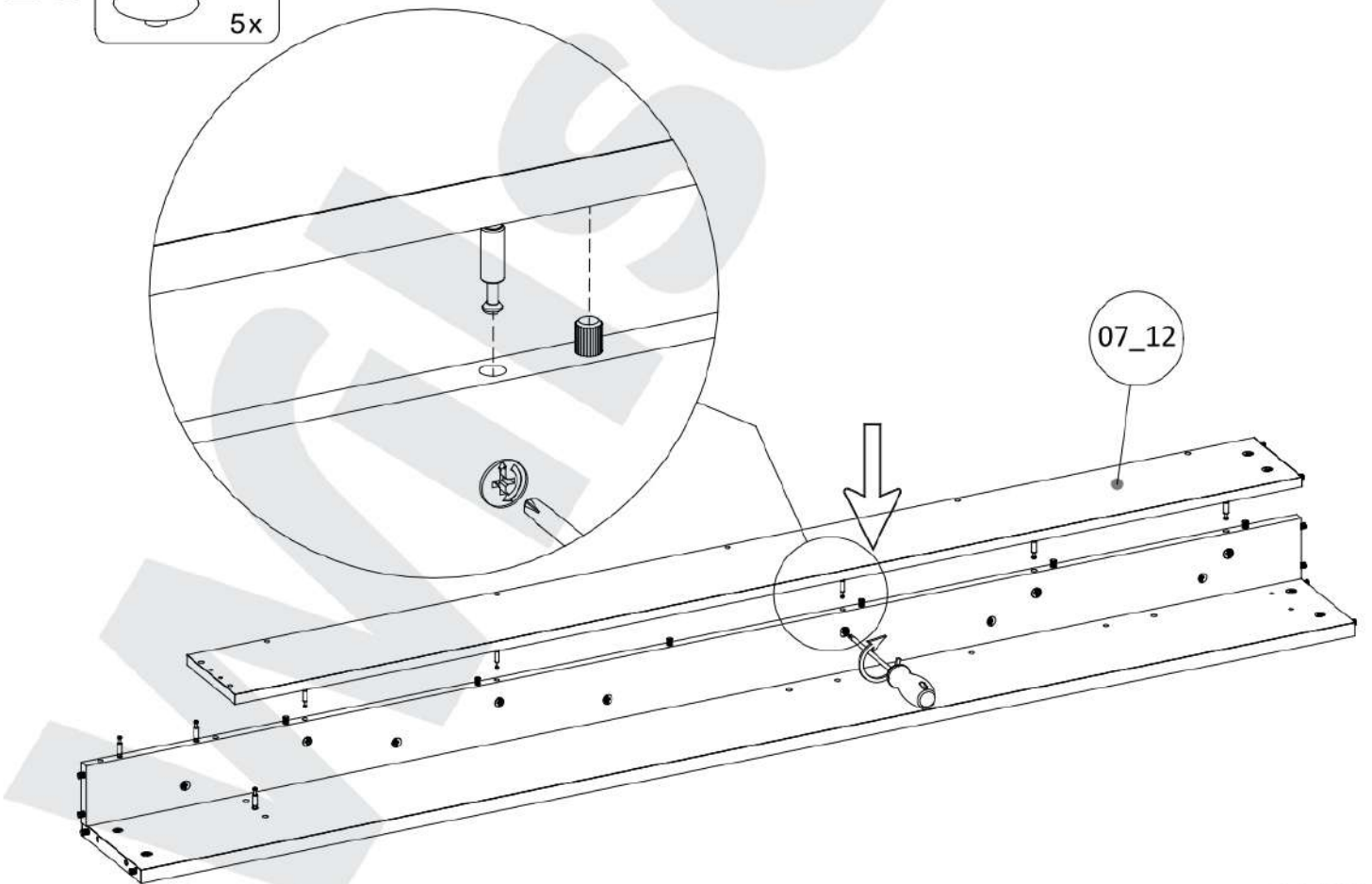
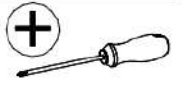

29

TM1
2x

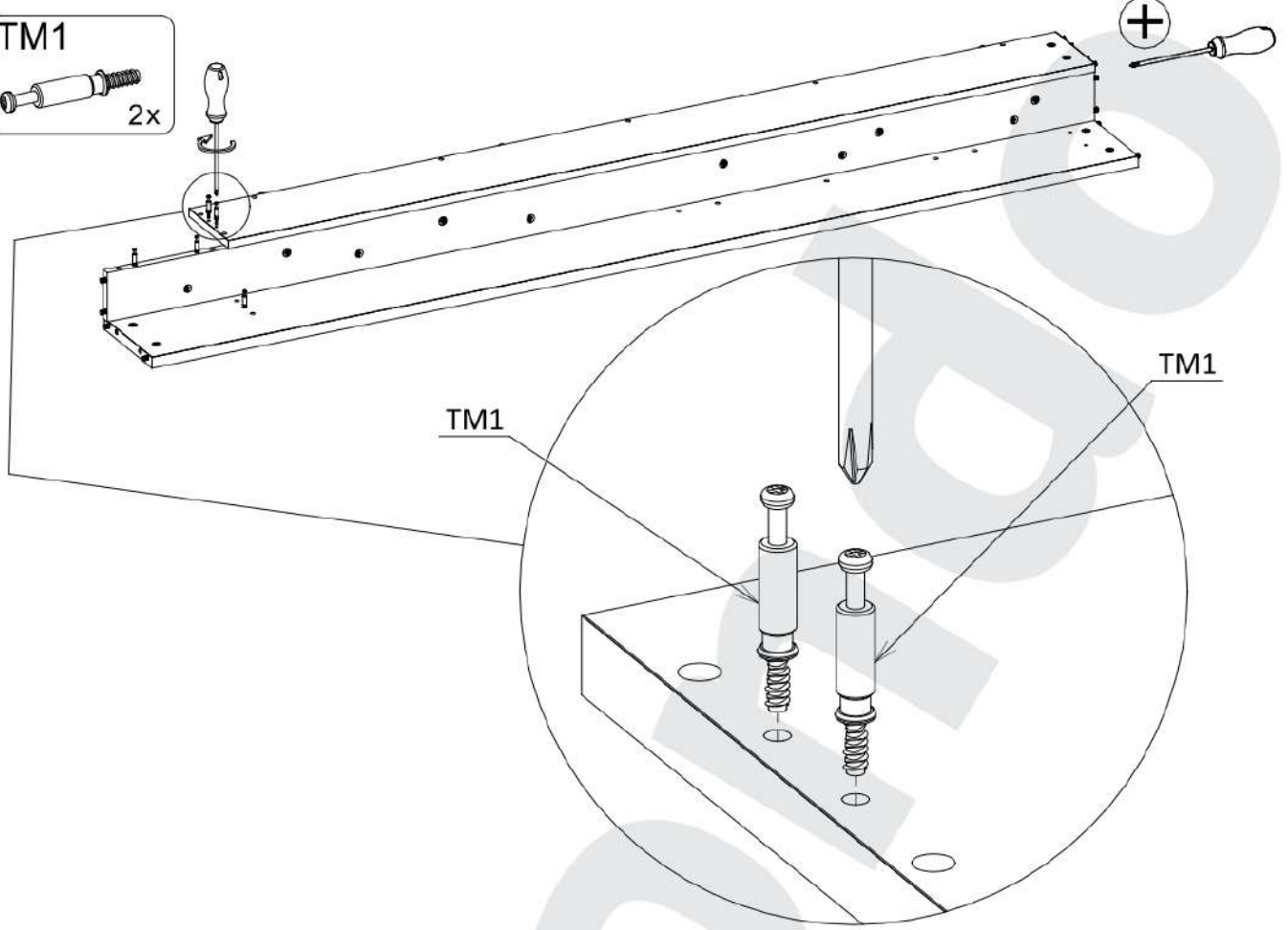

30

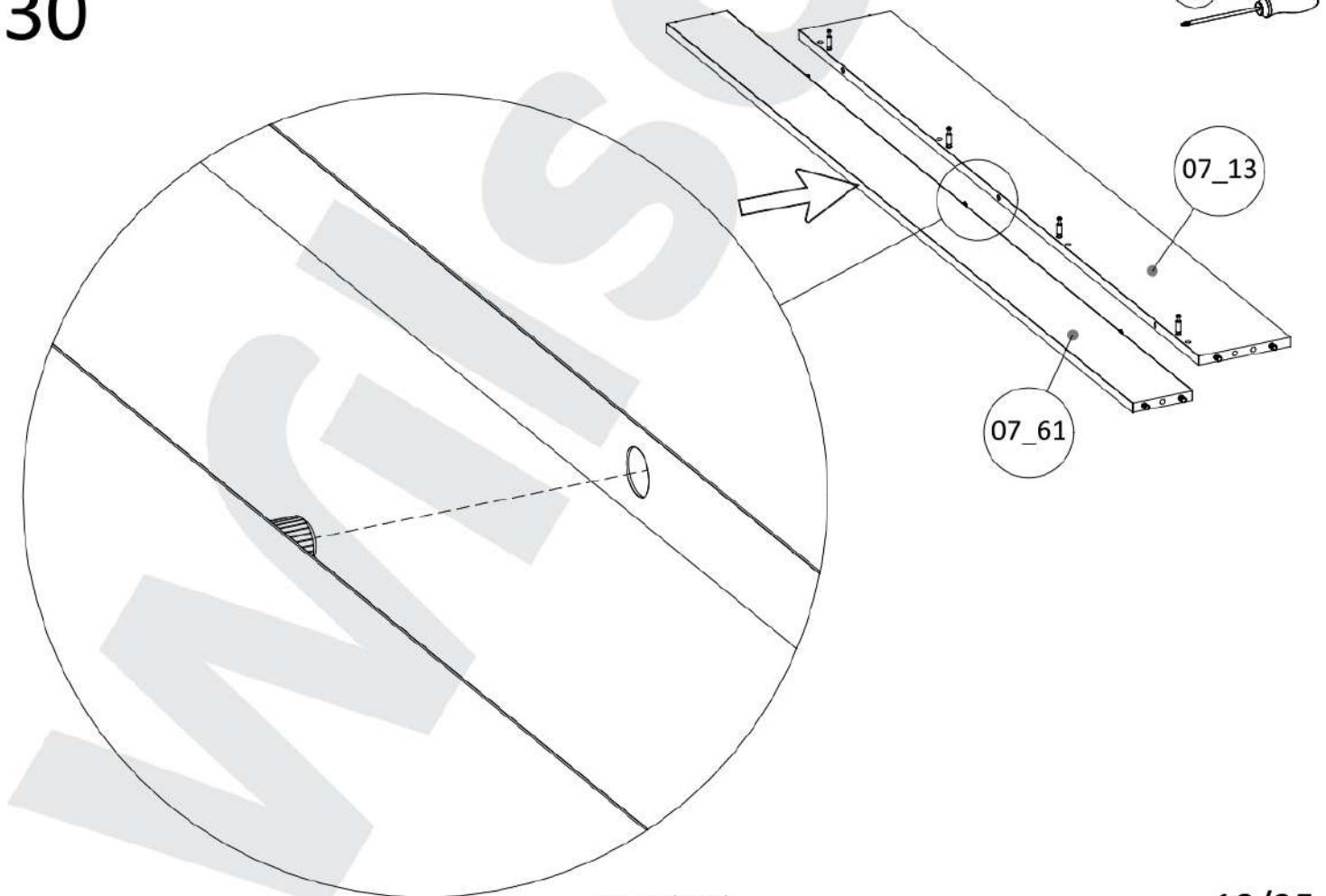
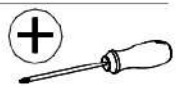

31

ZS12 $\varnothing 18$
K-02
4x

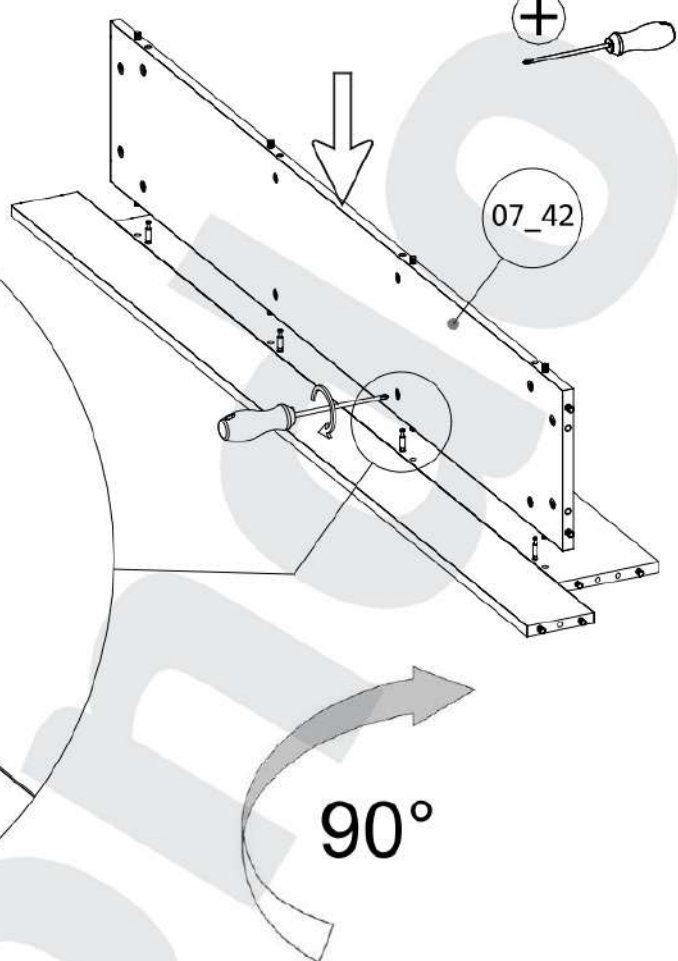
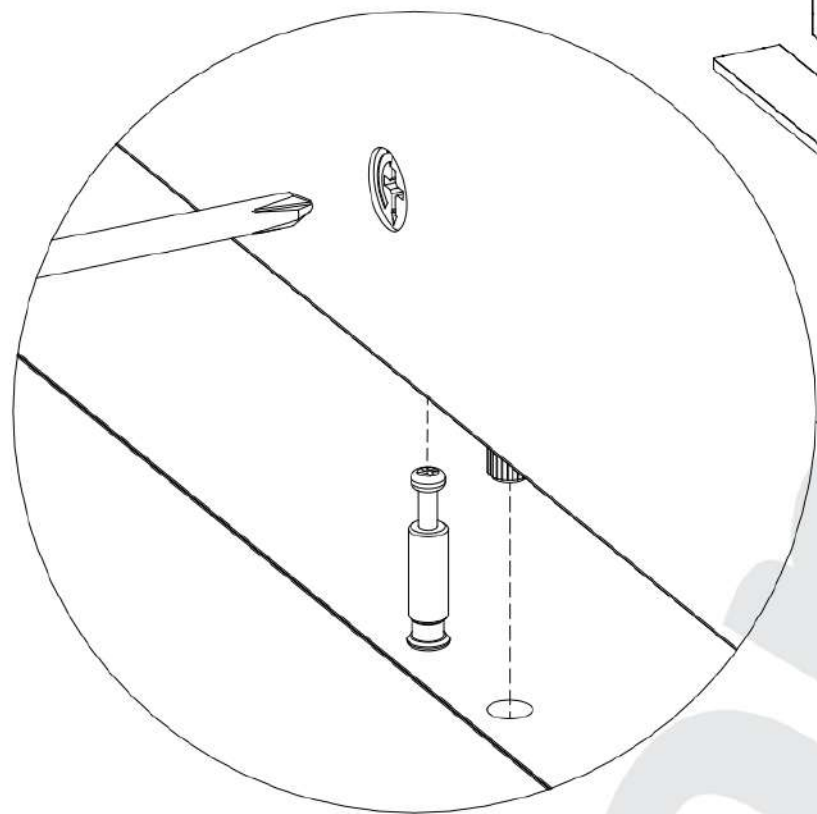

90°

32

ZS12 $\varnothing 18$
K-02
5x

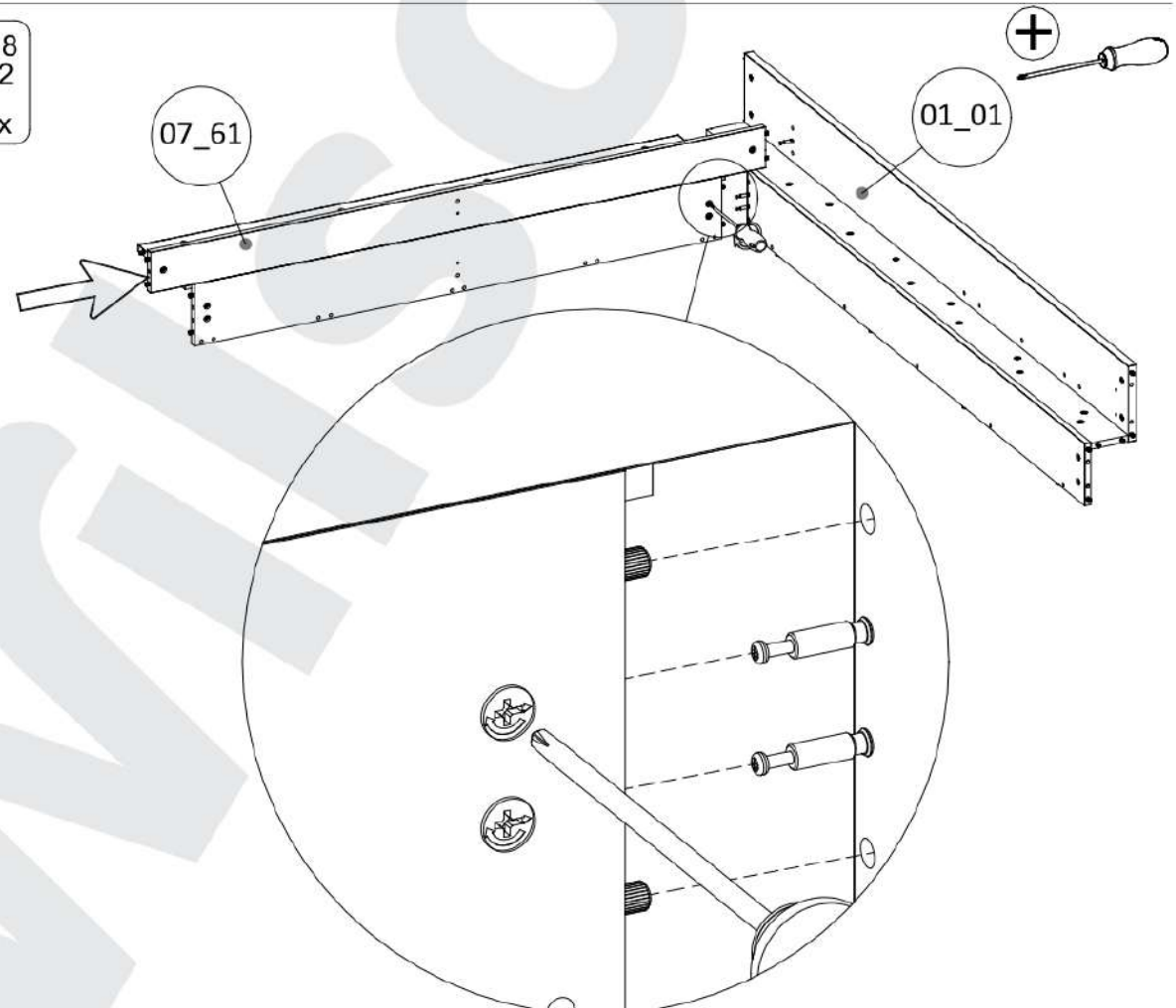

33

ZS12 $\phi 18$
K-02
5x

01_02

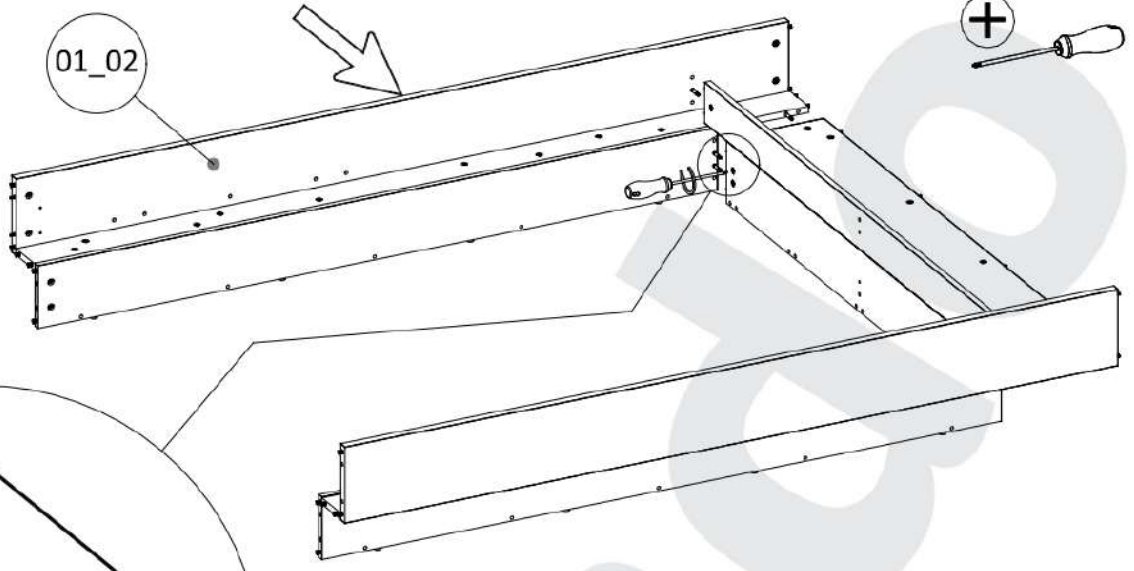
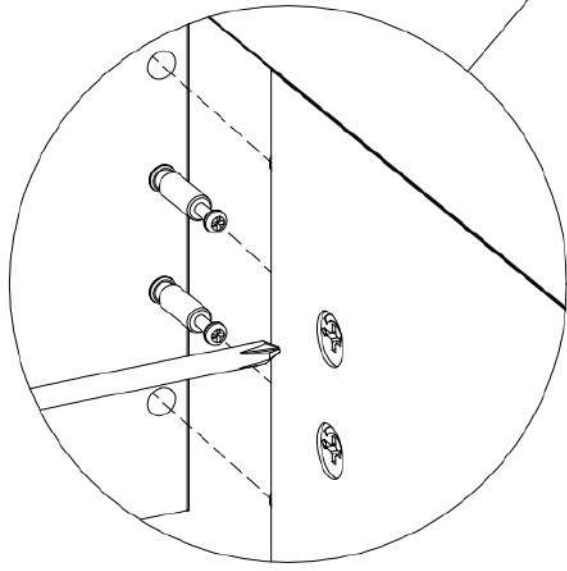

34

ZS12 $\phi 18$
K-03
2x

14_21

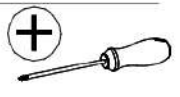

17_71

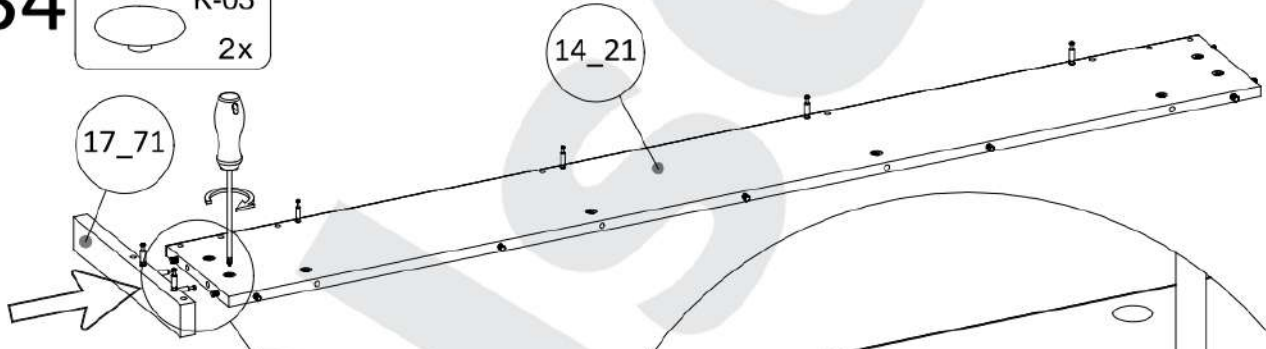
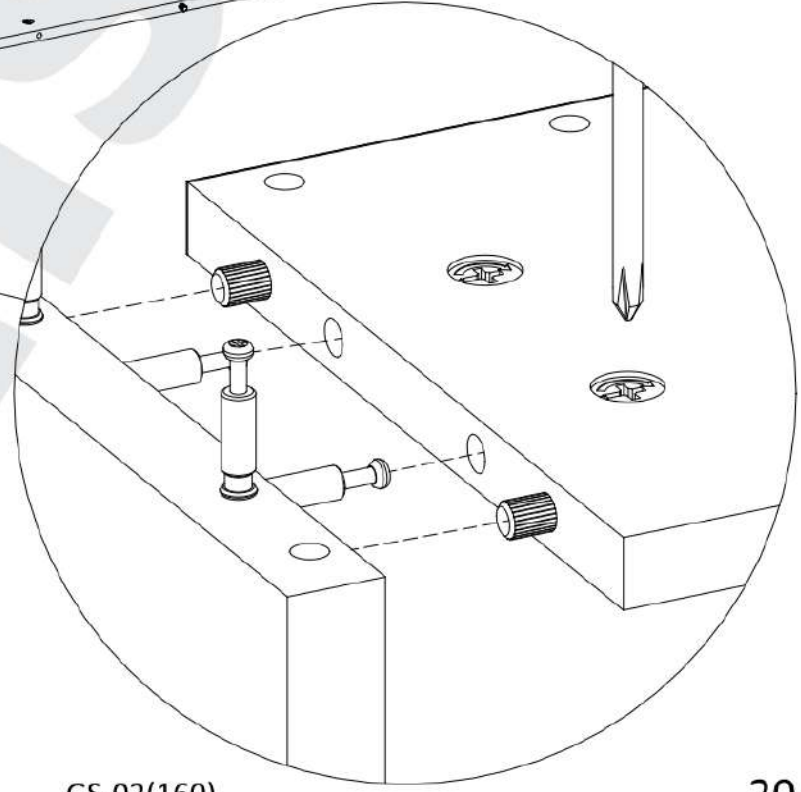

35

ZS12 $\varnothing 18$
K-03
2x

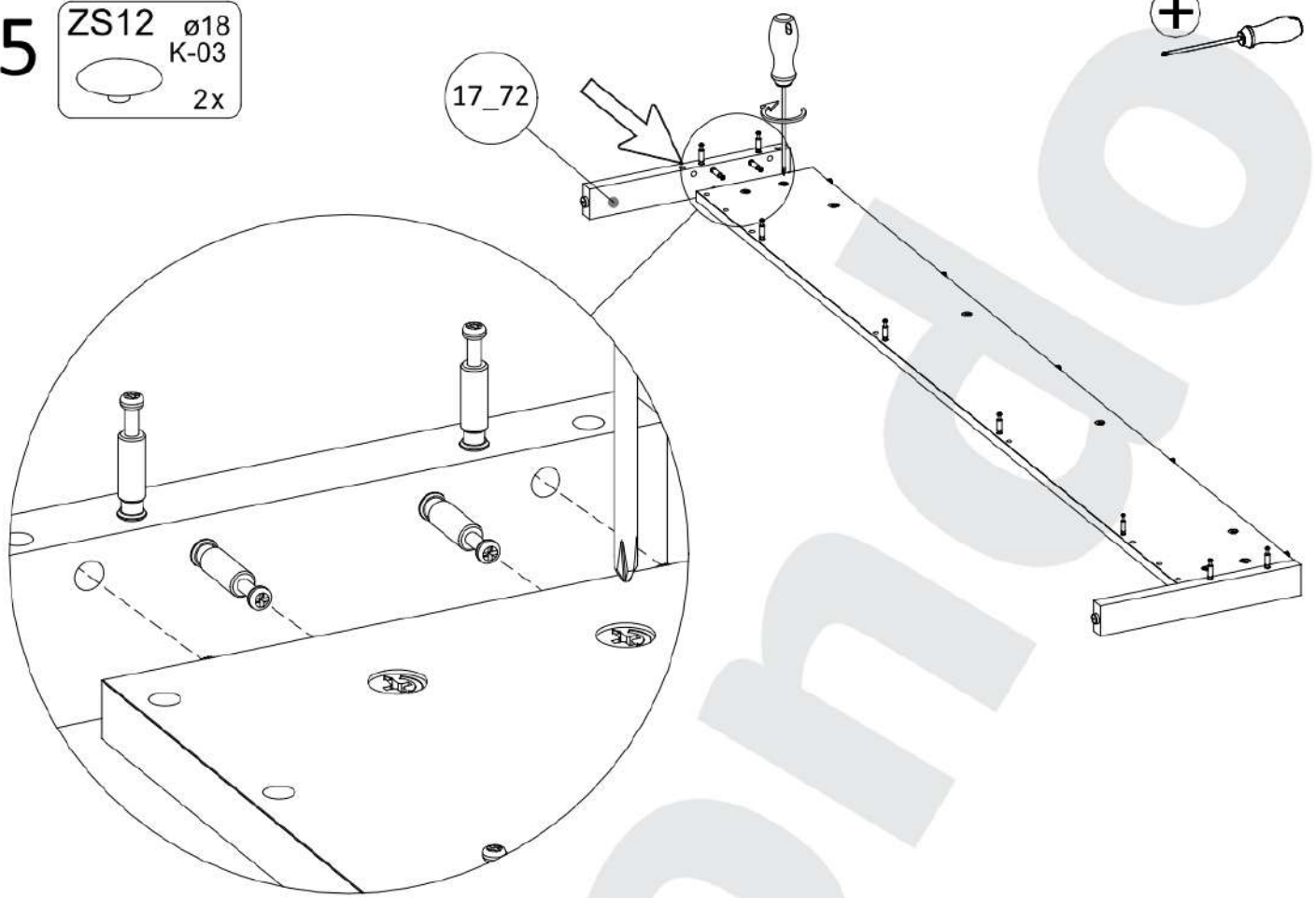

36

ZS12 $\varnothing 18$
K-03
4x

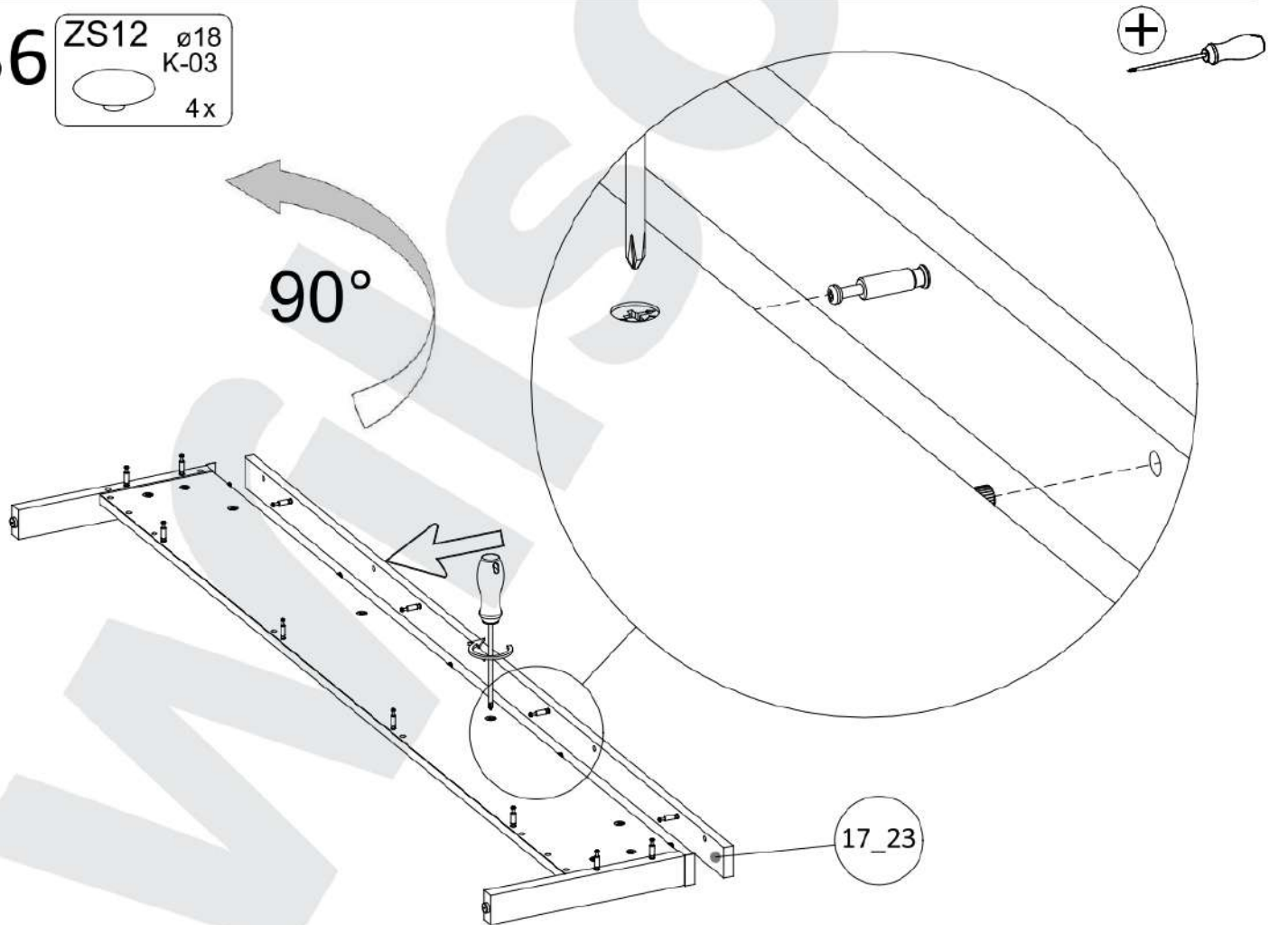

37

ZS12 $\varnothing 18$
K-02
4x

ZS12 $\varnothing 18$
K-03
4x

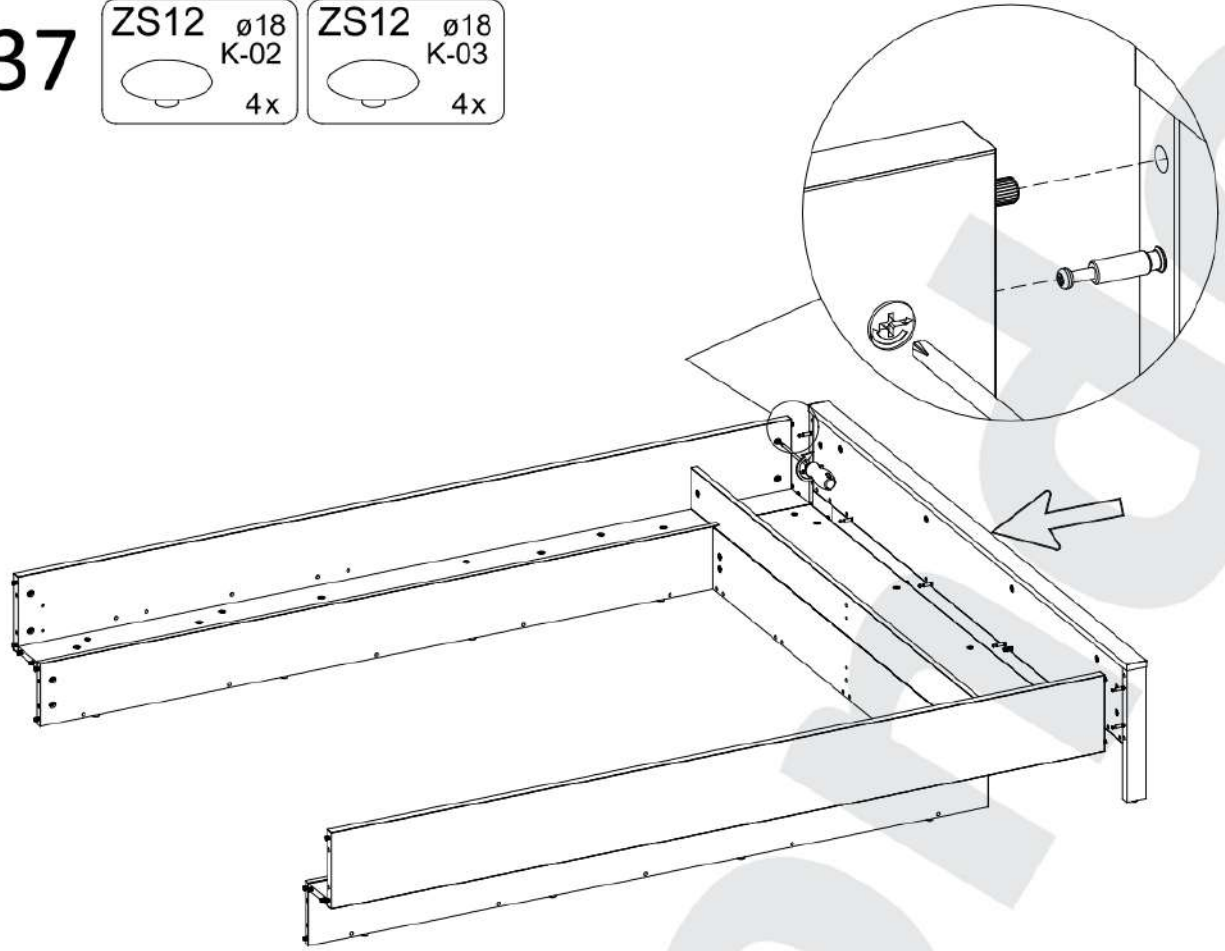

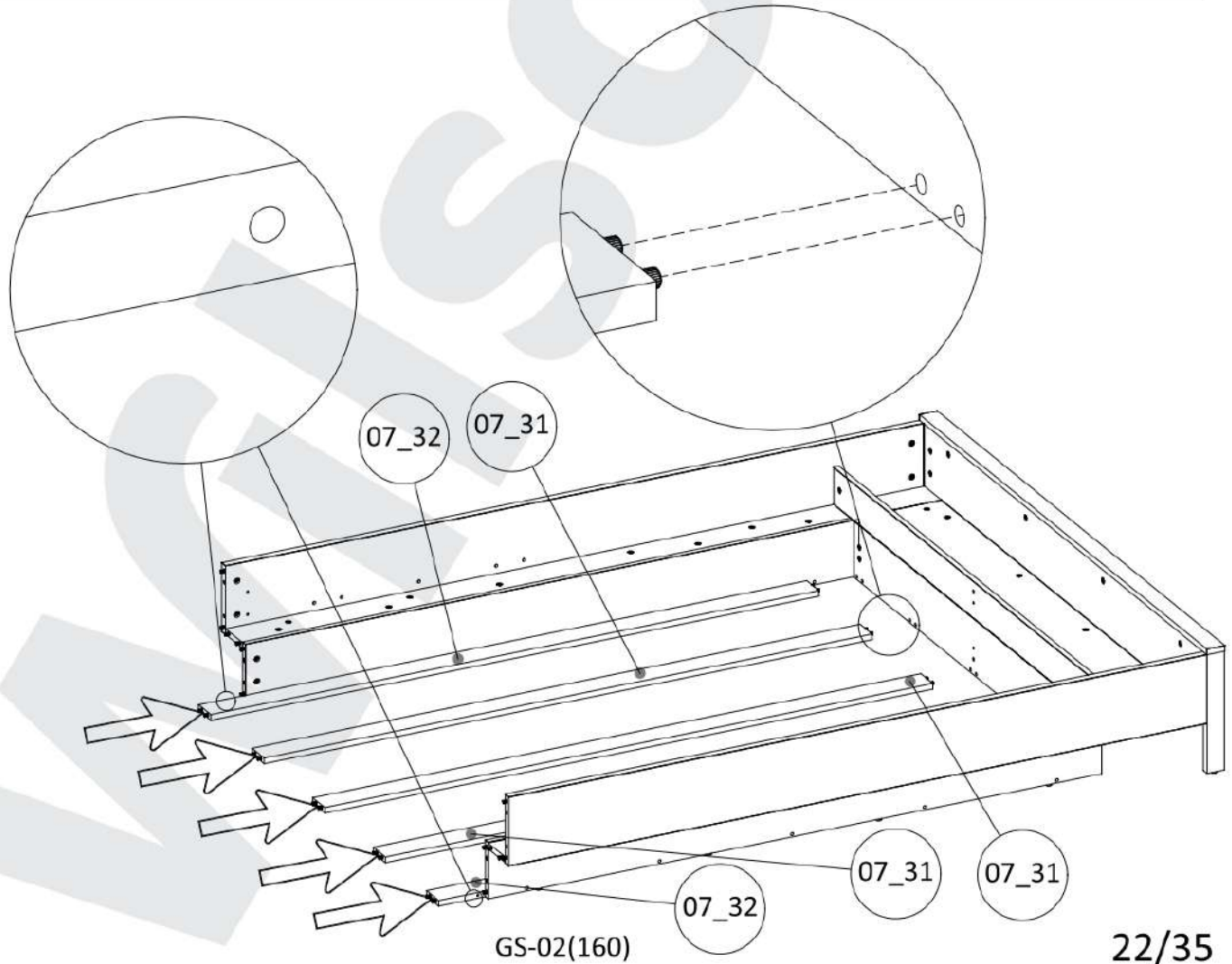

38

!



39

TM1

2x

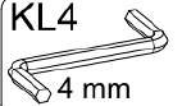
KN2 7x50

10x

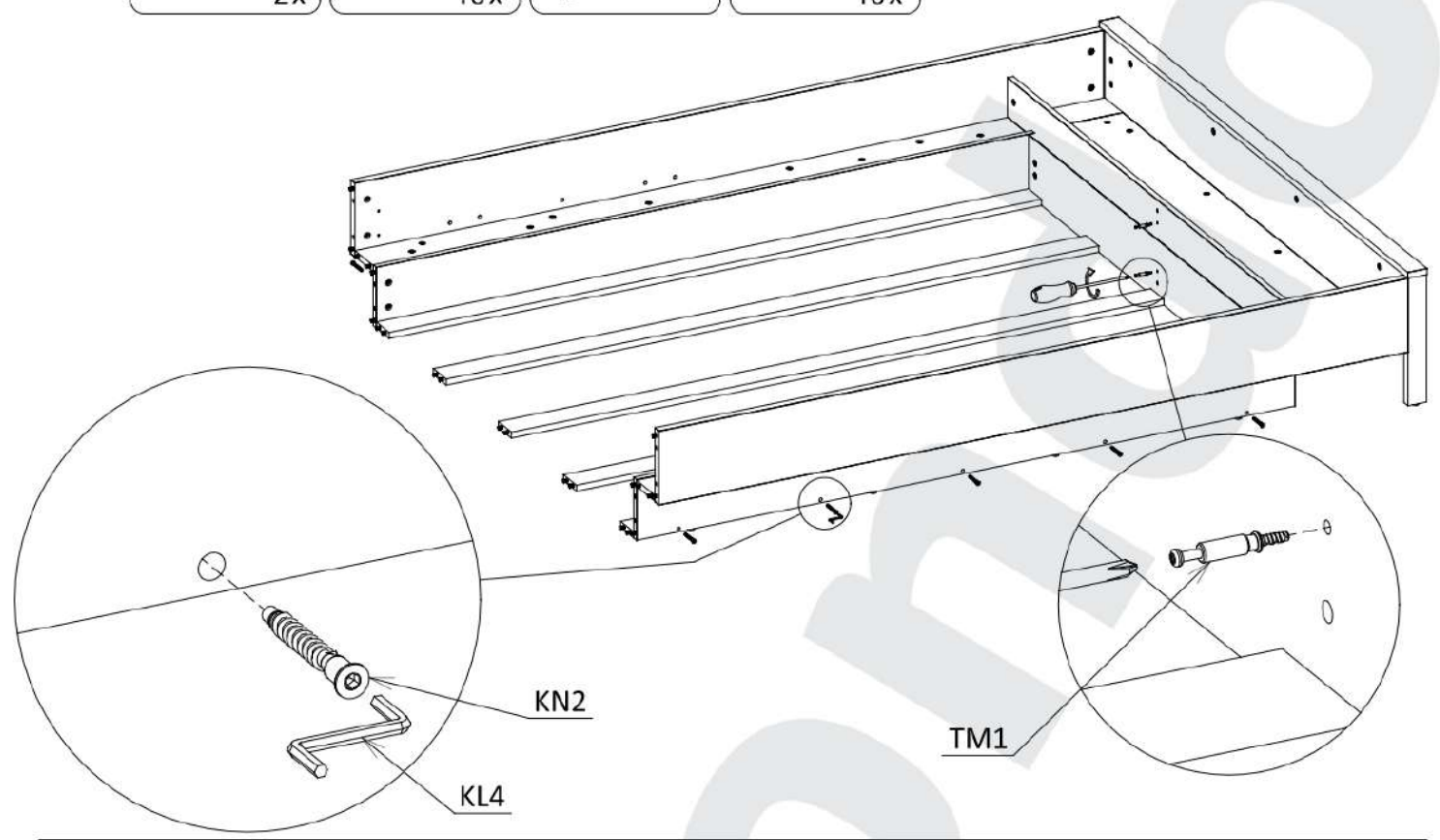
KL4

4 mm

ZSKN ø11
K-02

10x

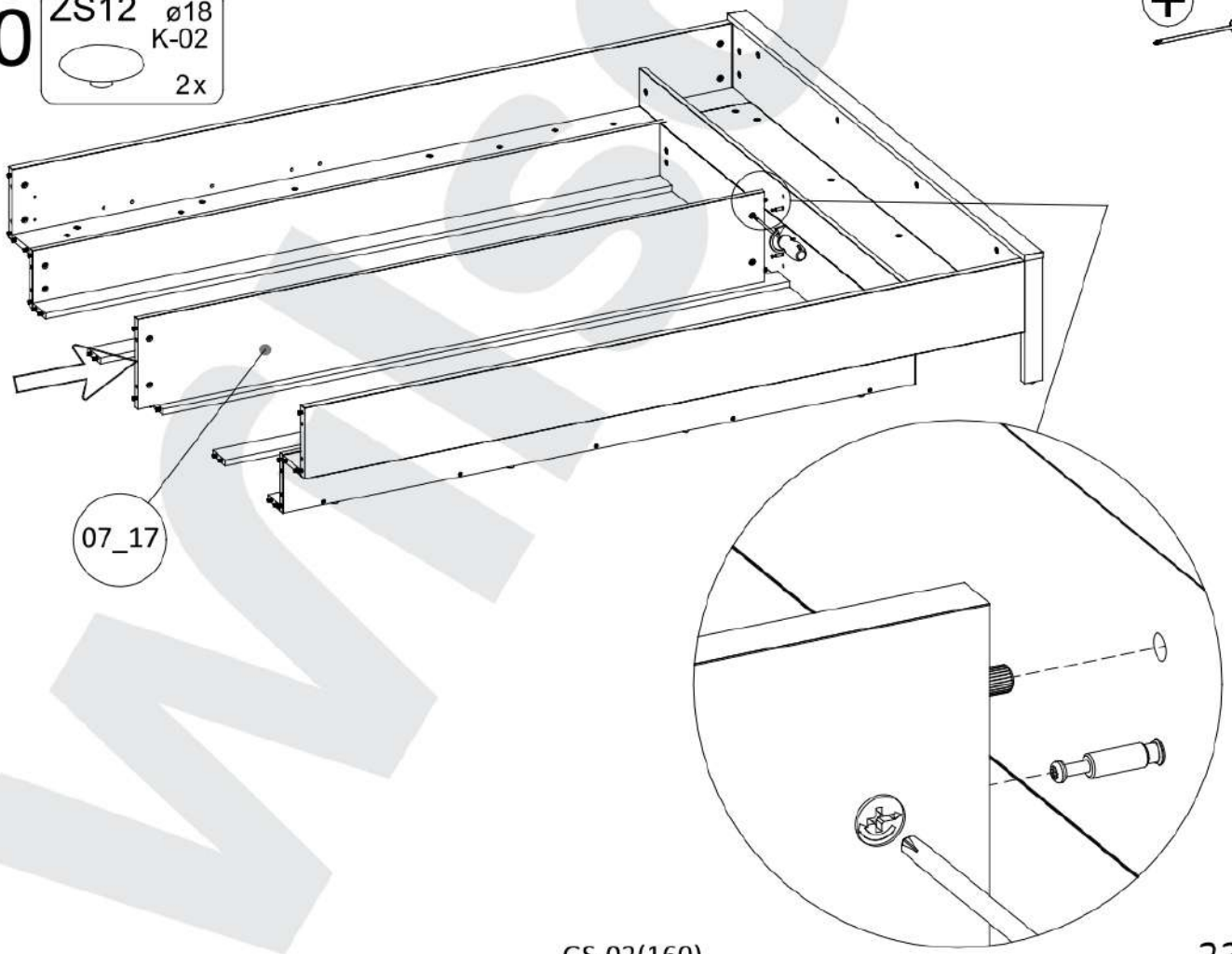
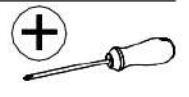

40

ZS12 ø18
K-02

2x

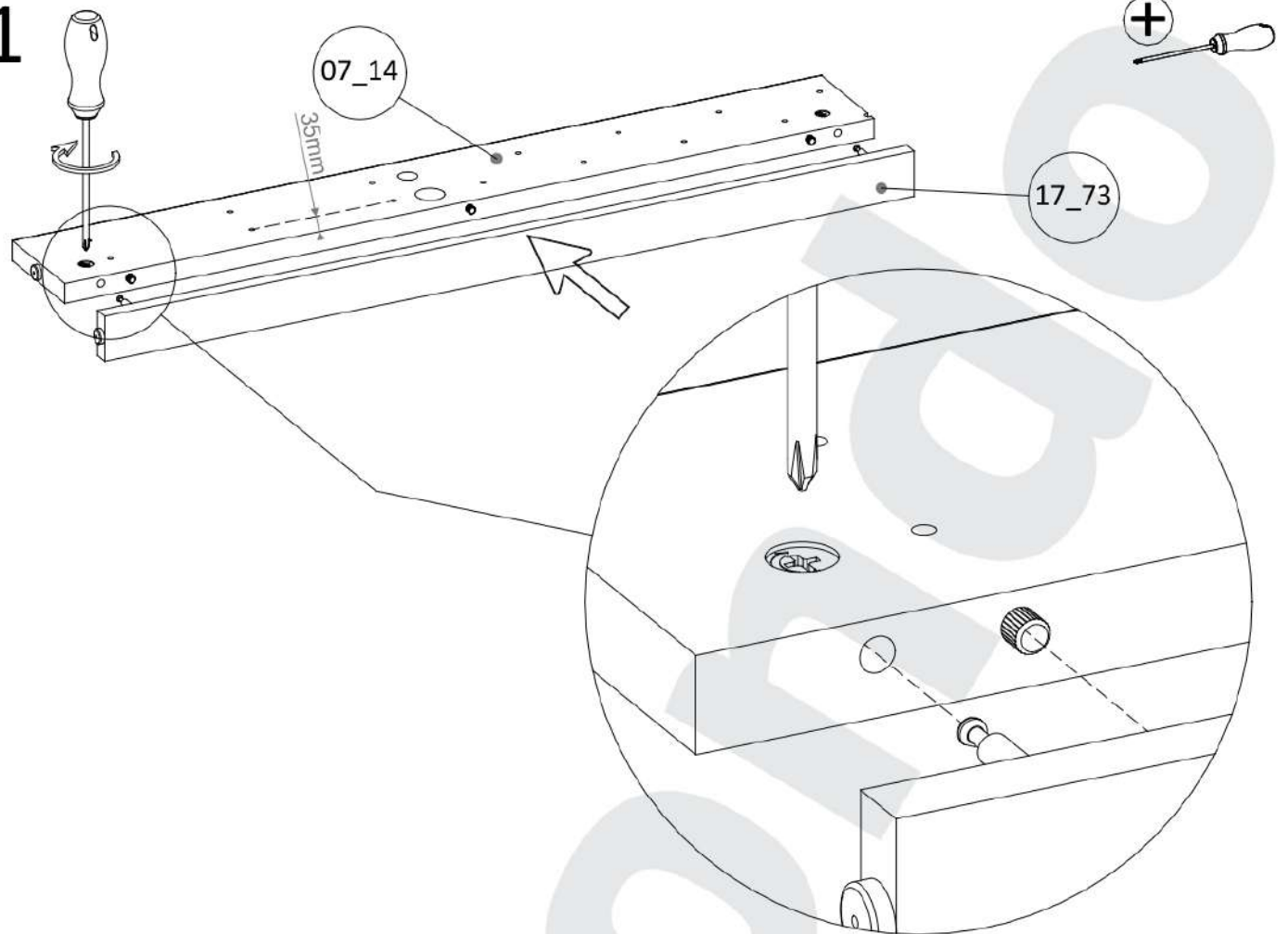

41

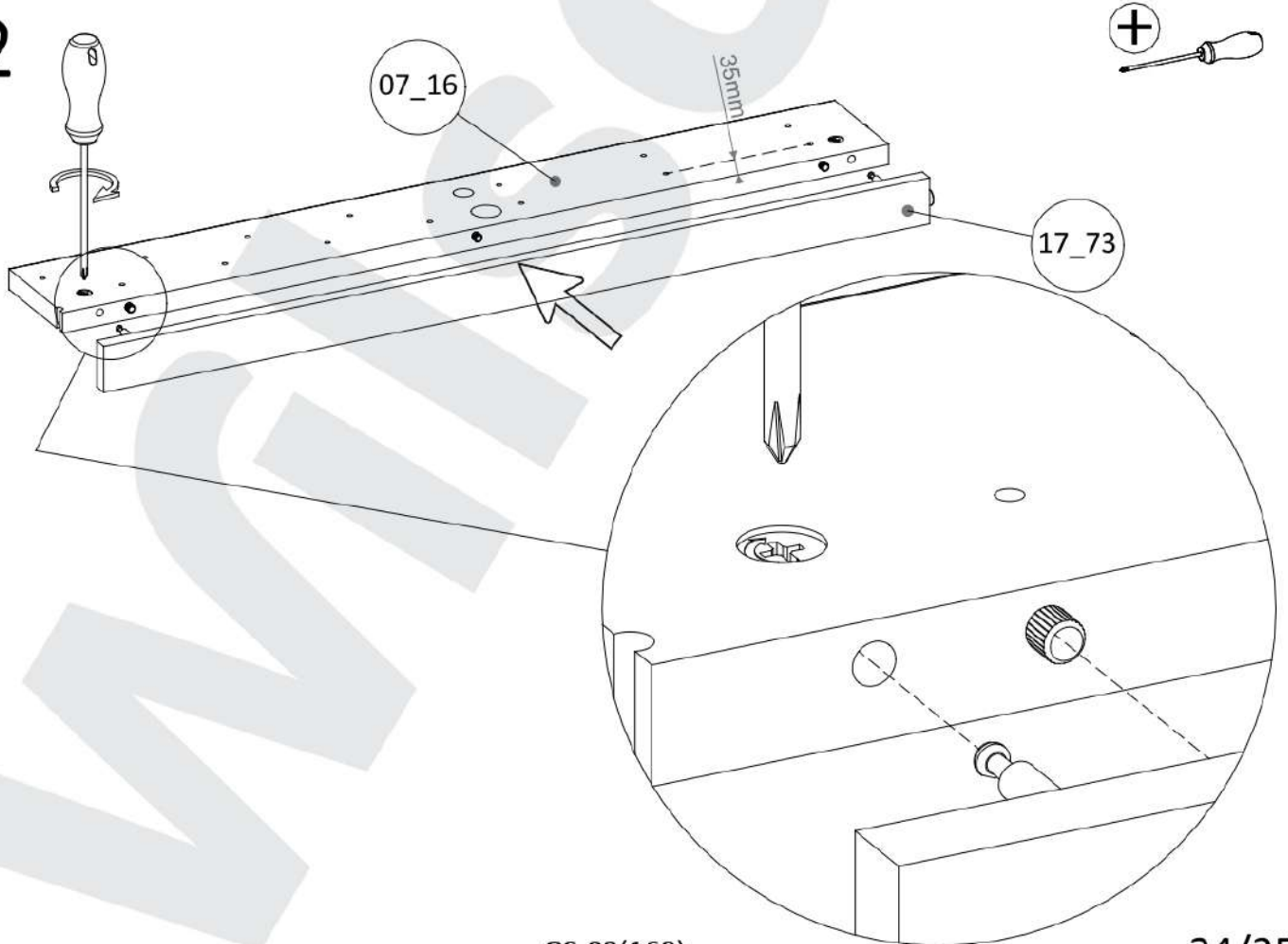

42



43

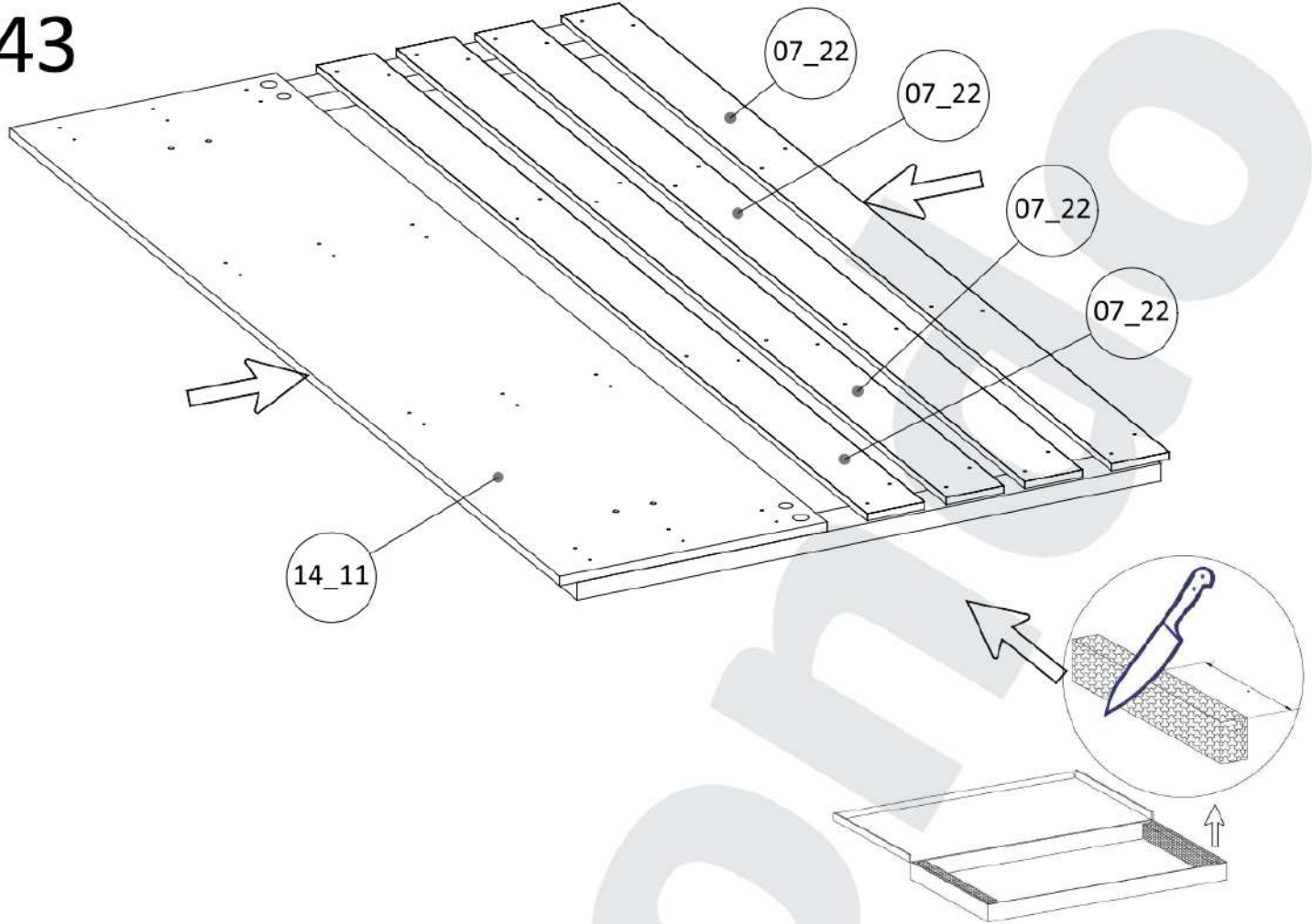

44

WE65 5x32
24x

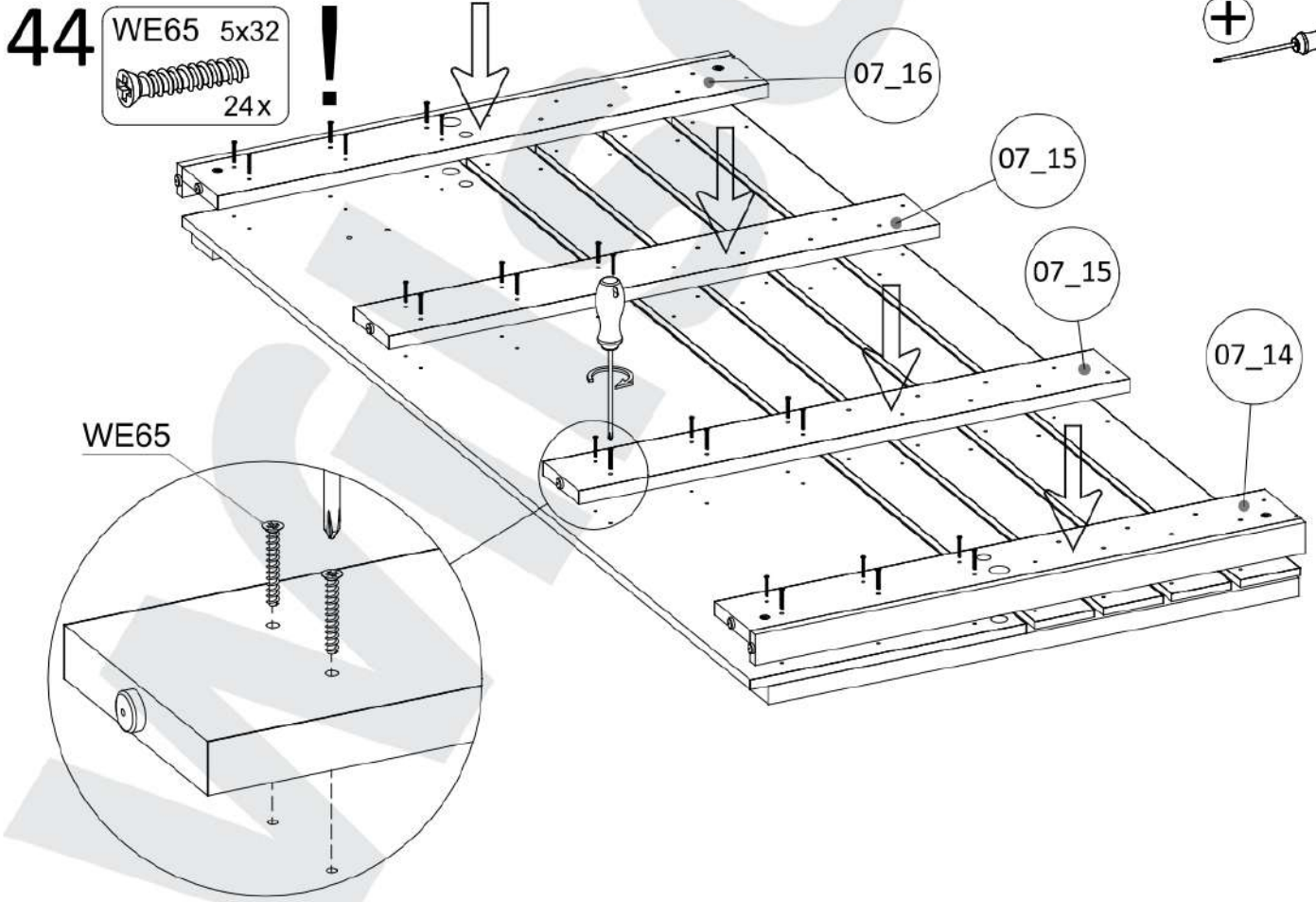
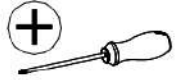

45

WE64 5x30
32x

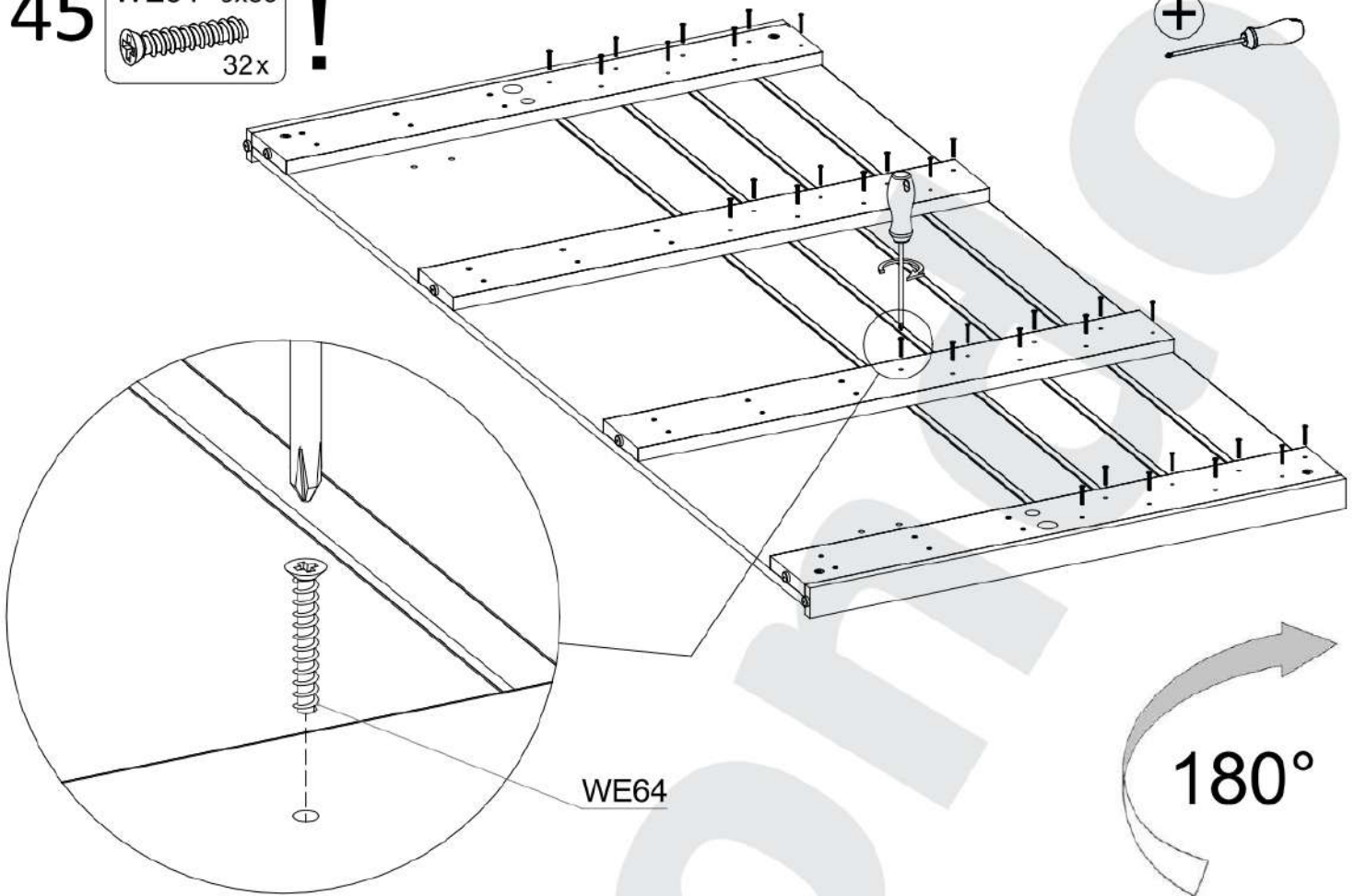
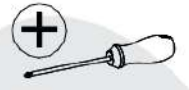

WE64

180°

46

TM1
10x

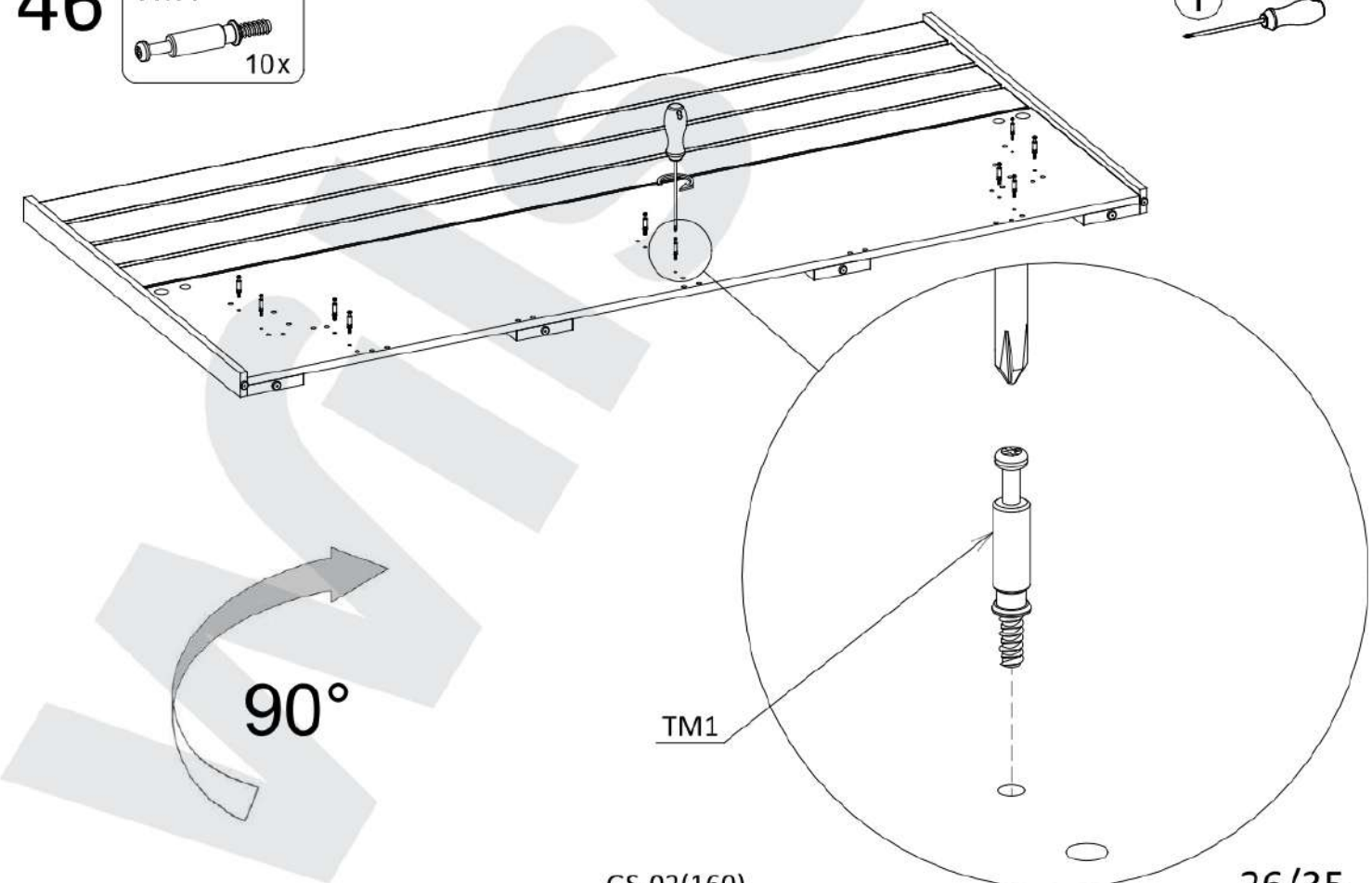
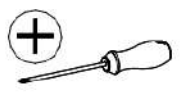

TM1

90°

47

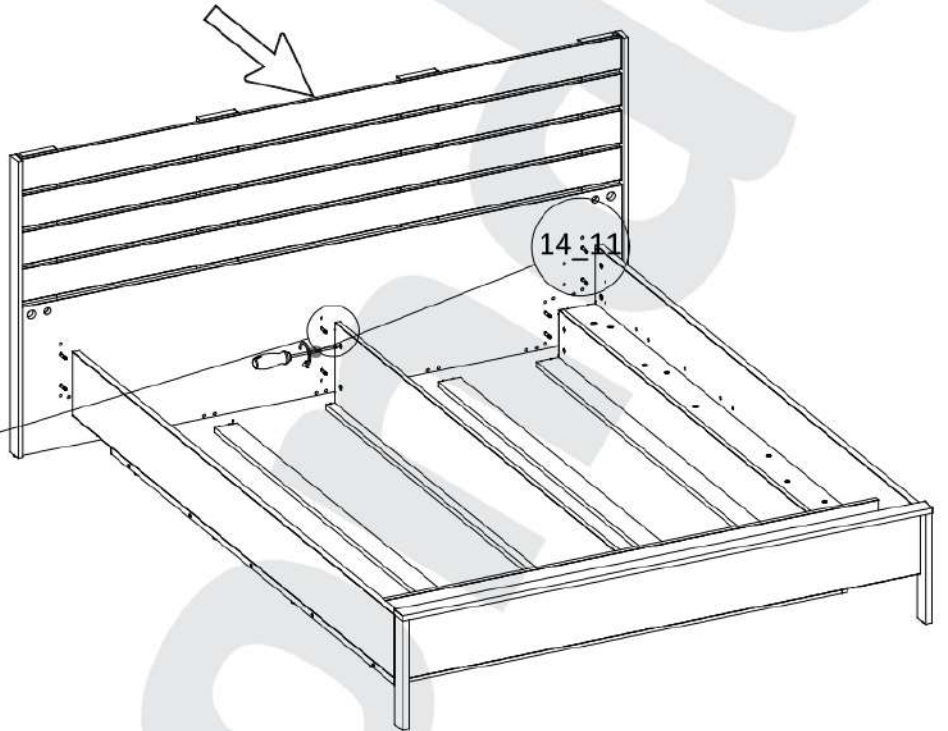
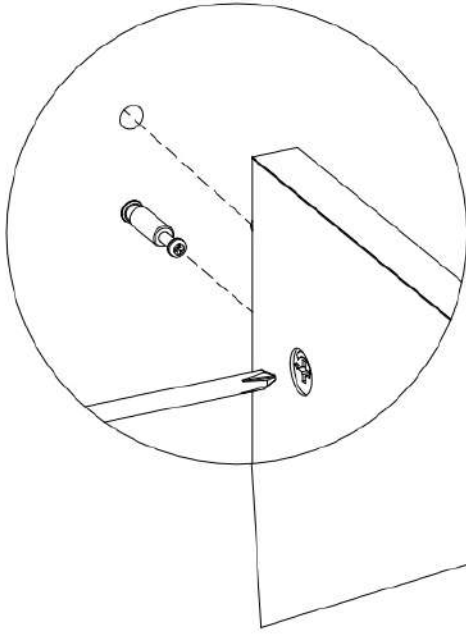
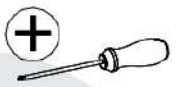
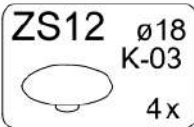
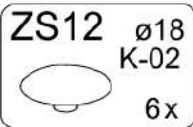

48

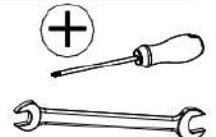
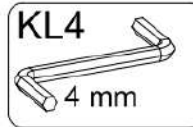
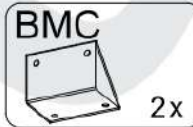
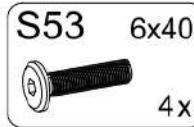
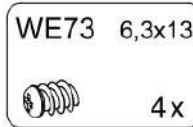

10 / 13

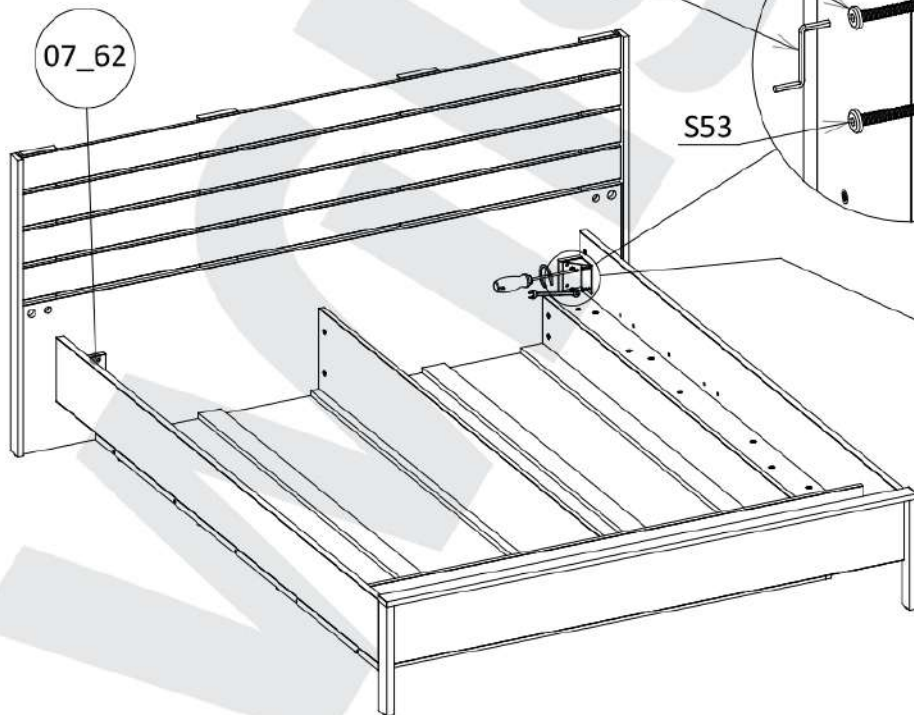

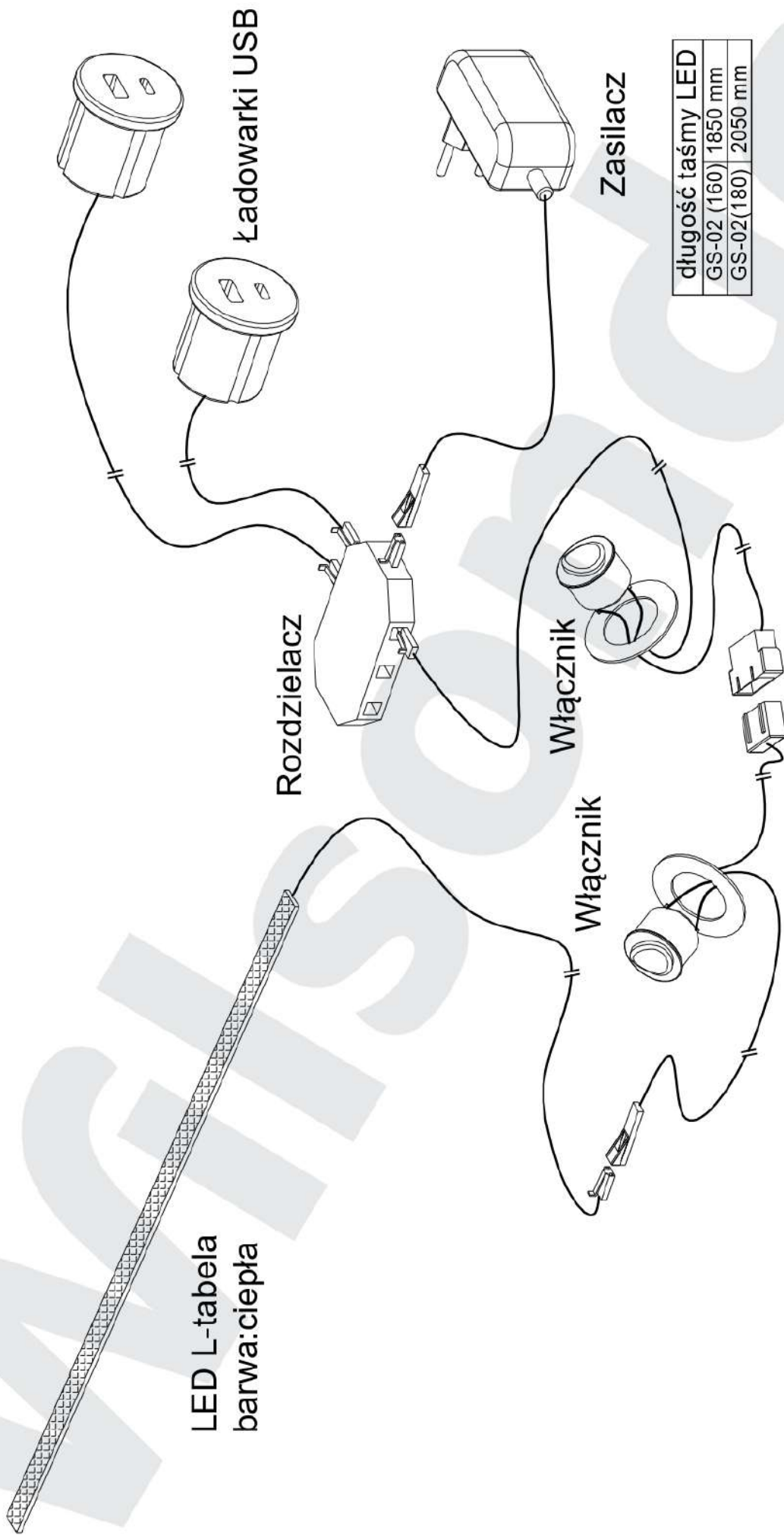

sporządził:	R.O	sprawdził:	-	.	.	.
GRIS			GS-02 (160)		ZESTAW OŚWIETLENIOWY	

49

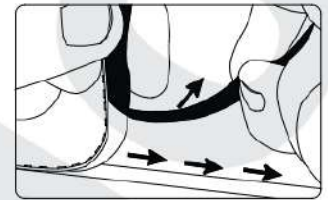
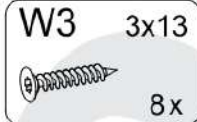
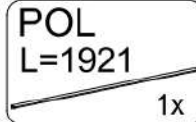
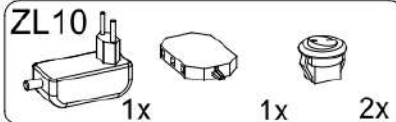
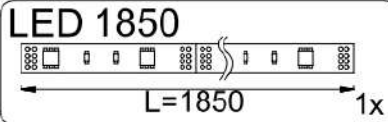

POL

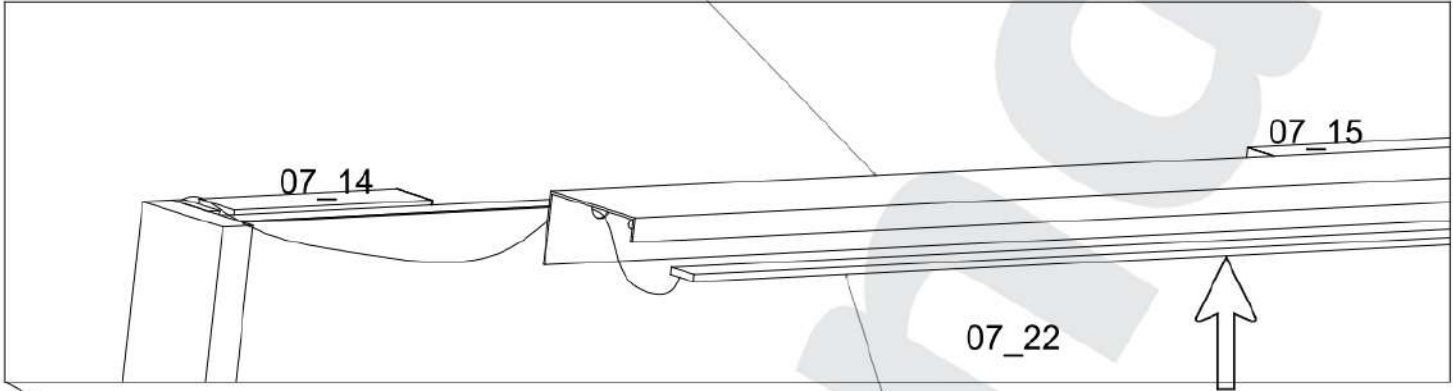

LED1850

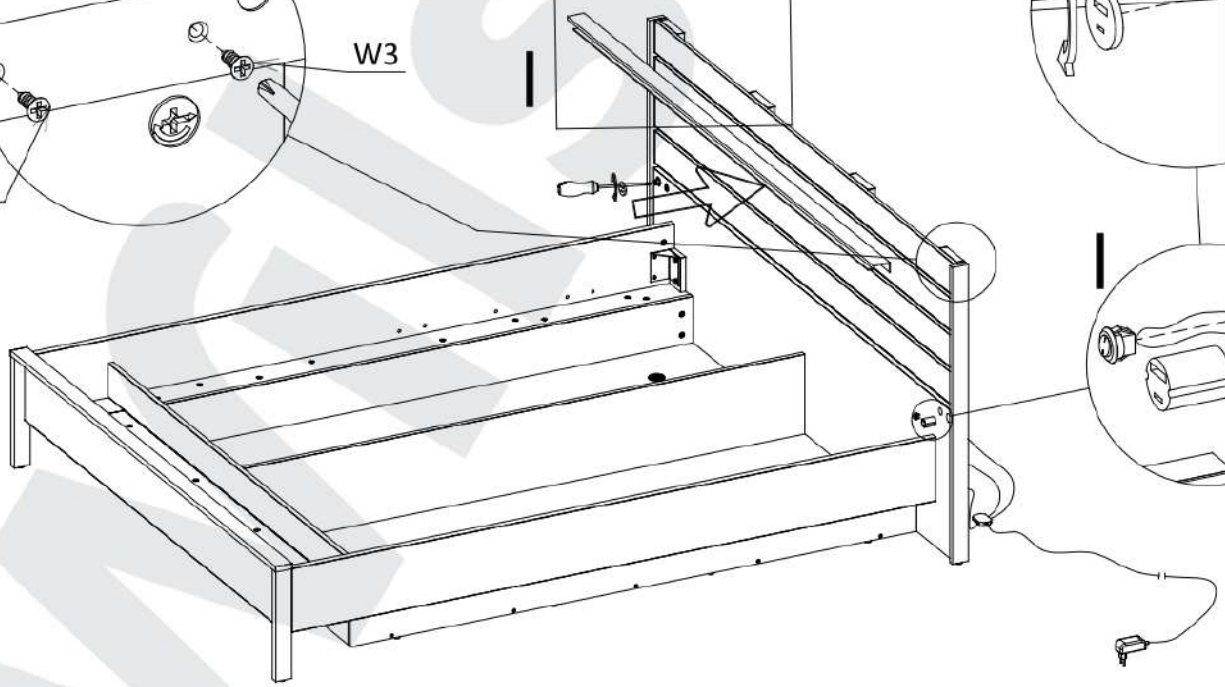
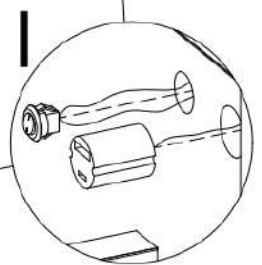
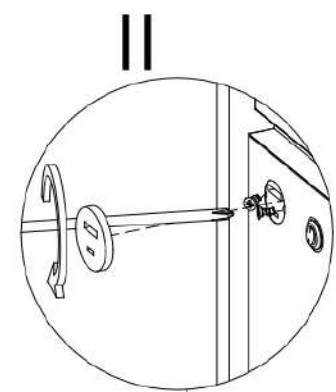
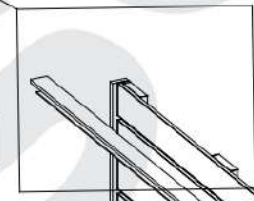
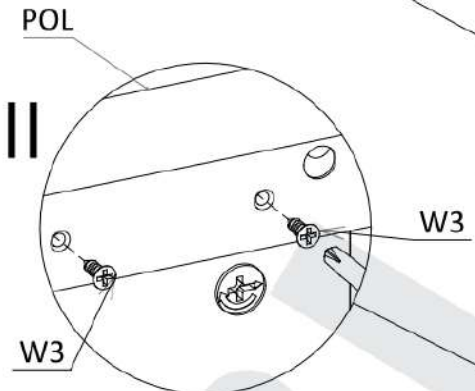

50

S92 6x16
10x

P6 6x18
10x

PO-000320B01P

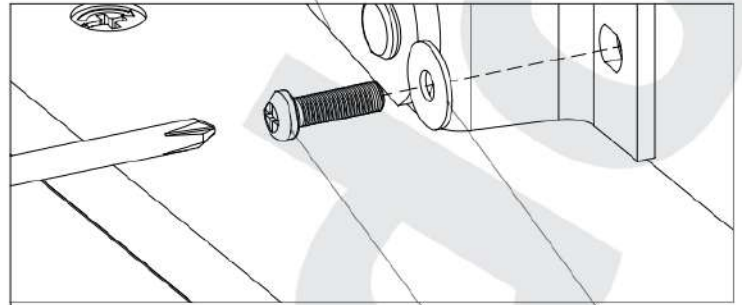

S92 P6

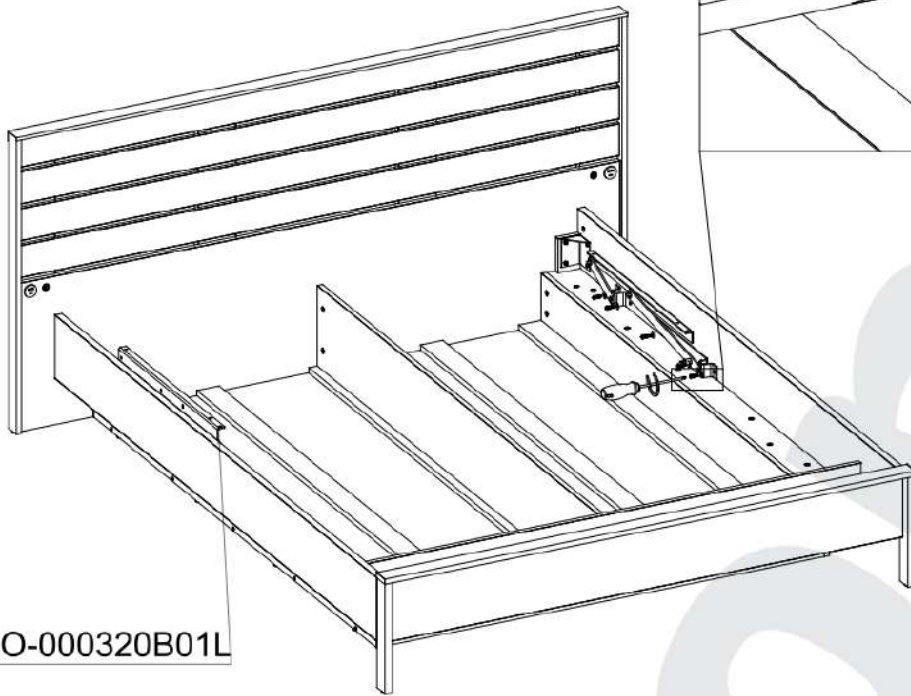

PO-000320B01L

51

W550 5x50
4x

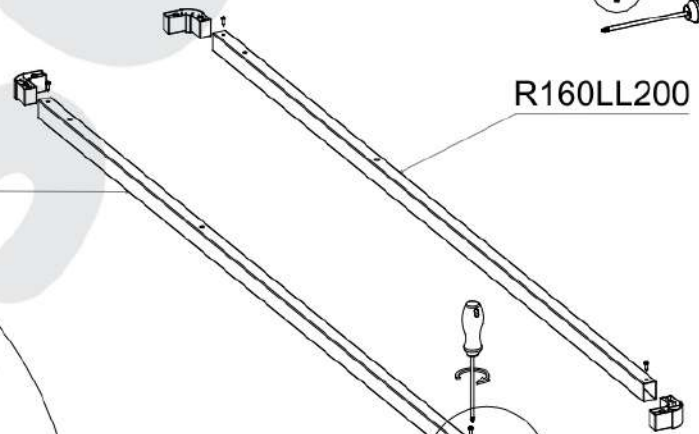
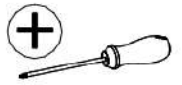

R160LL200

R160PL200

W550

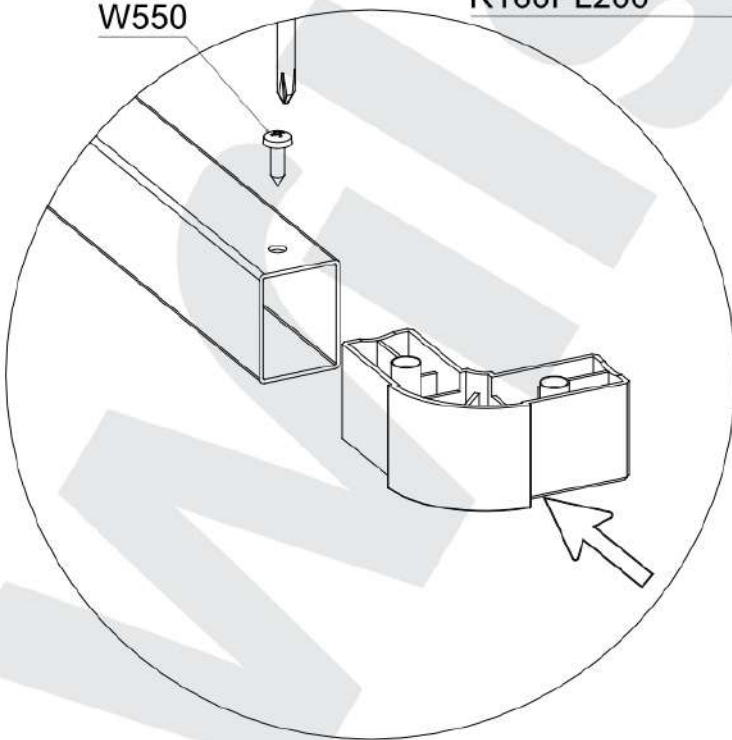

52

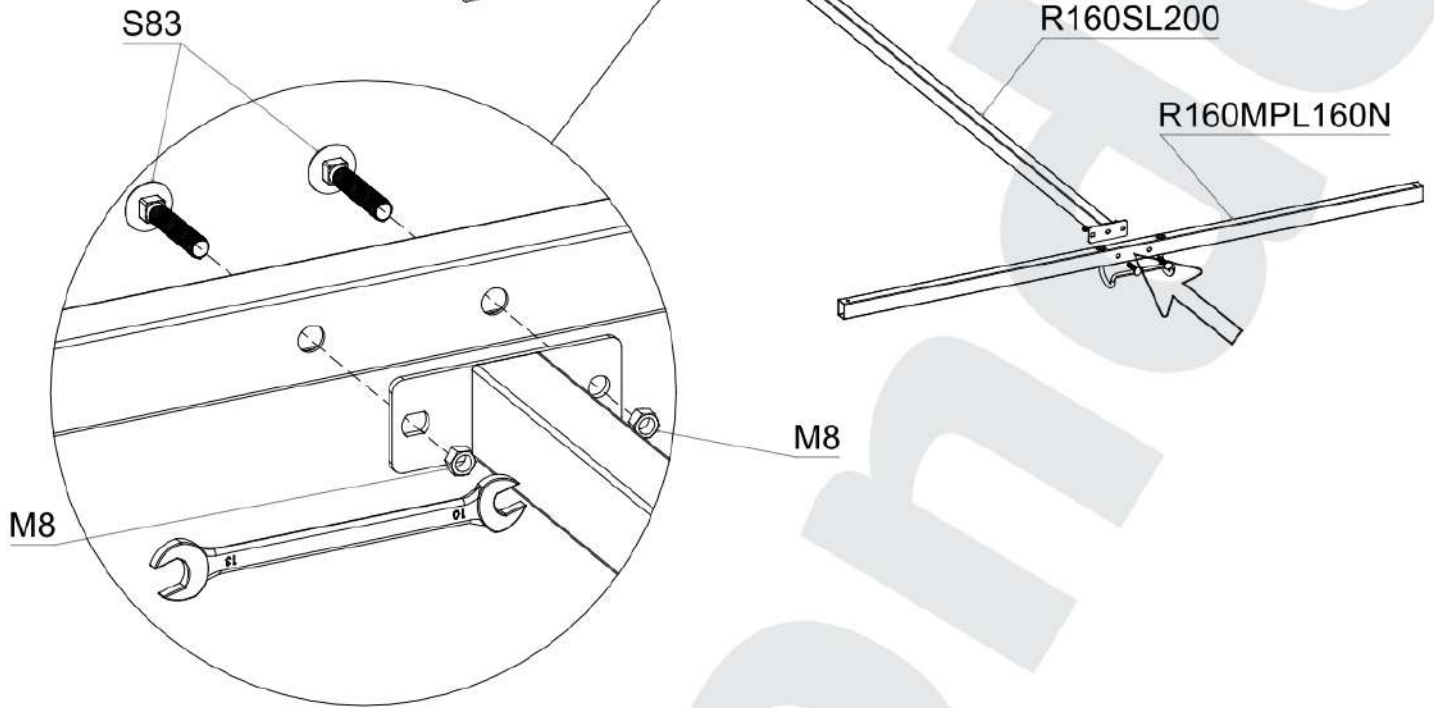
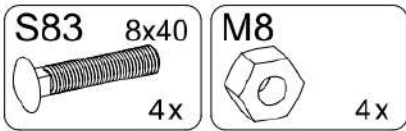

53

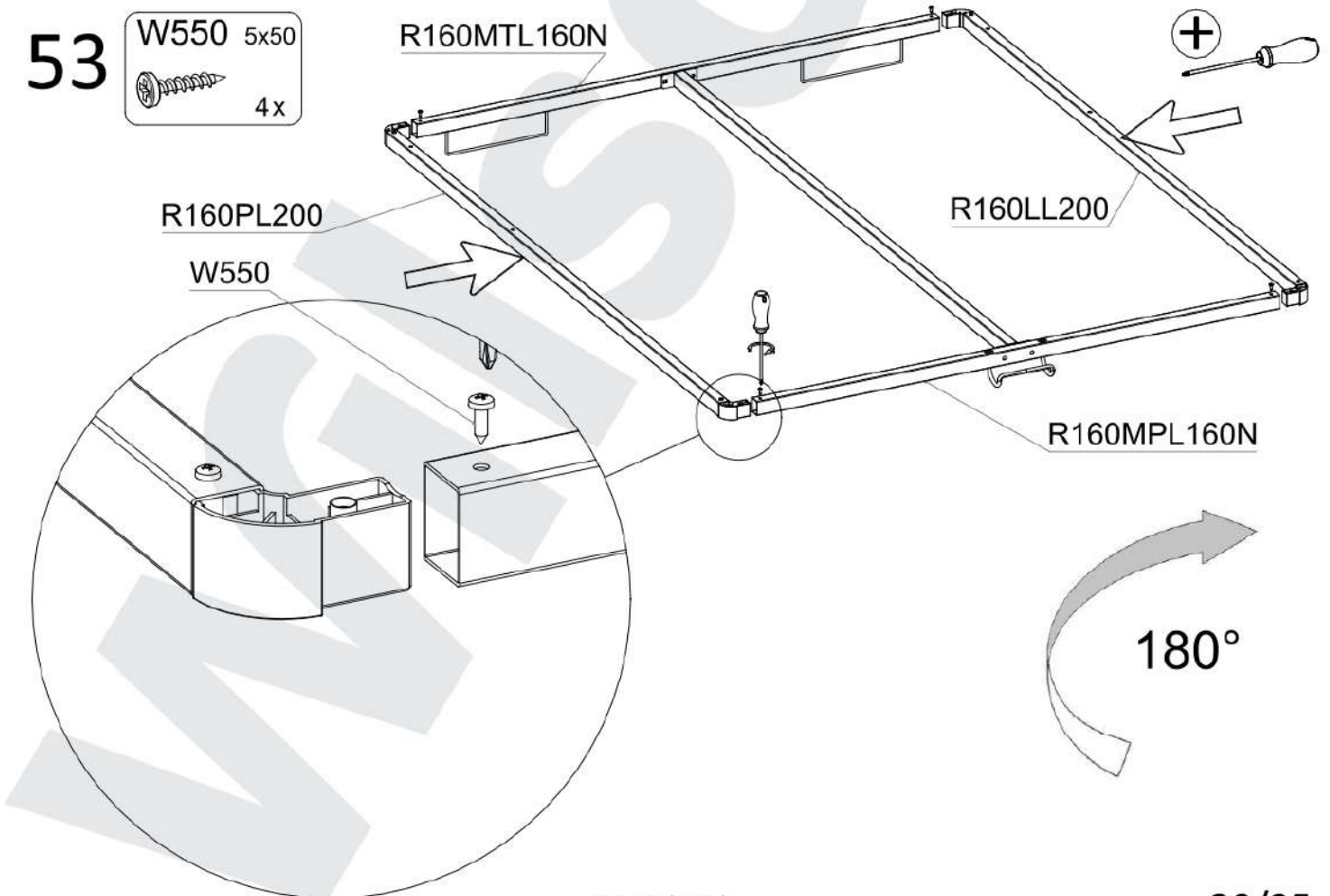
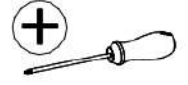
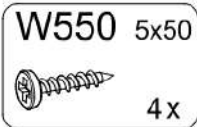

54

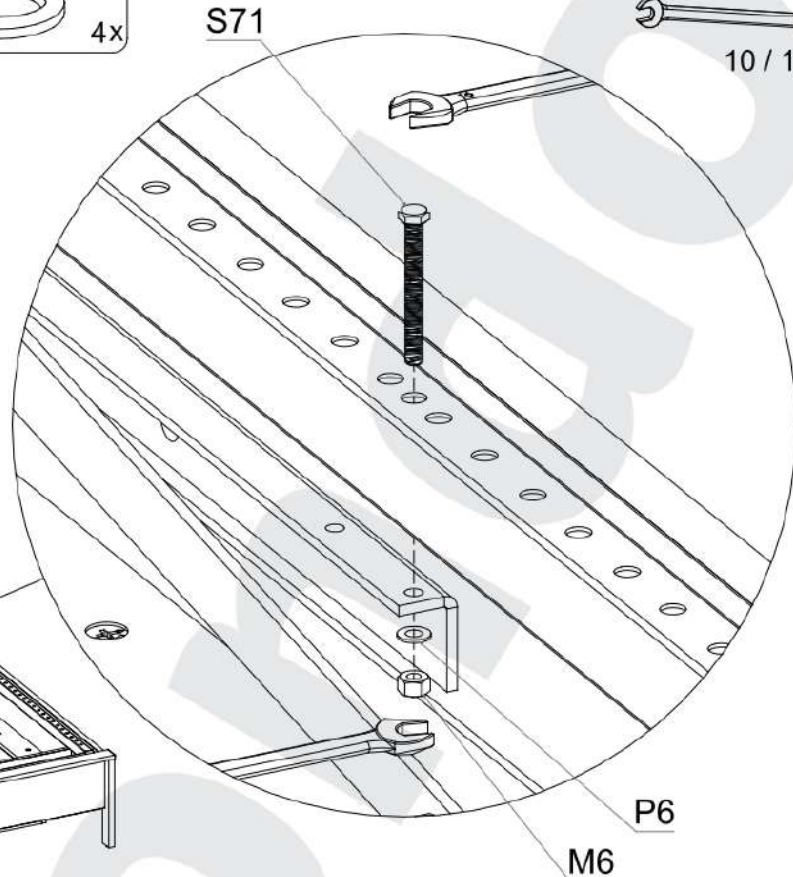
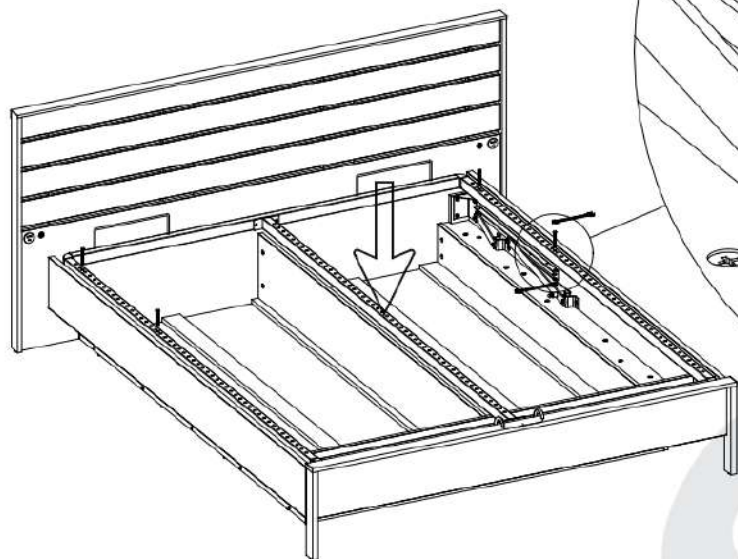
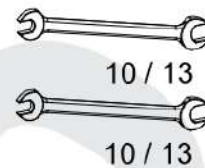
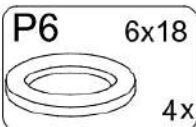
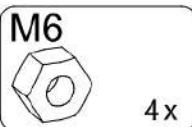
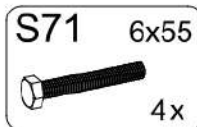

55

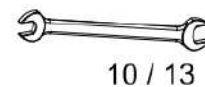
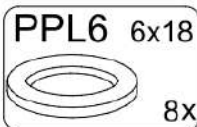
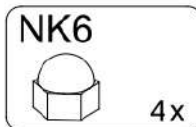

PB-037-05-037-1000

PPL6
NK6

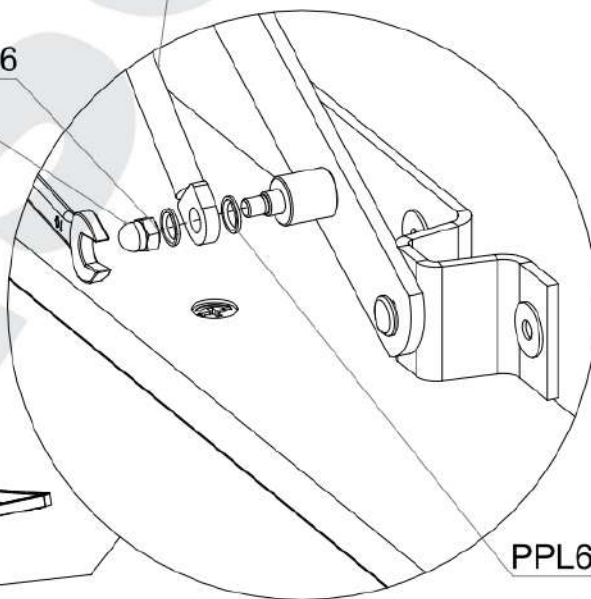

PPL6

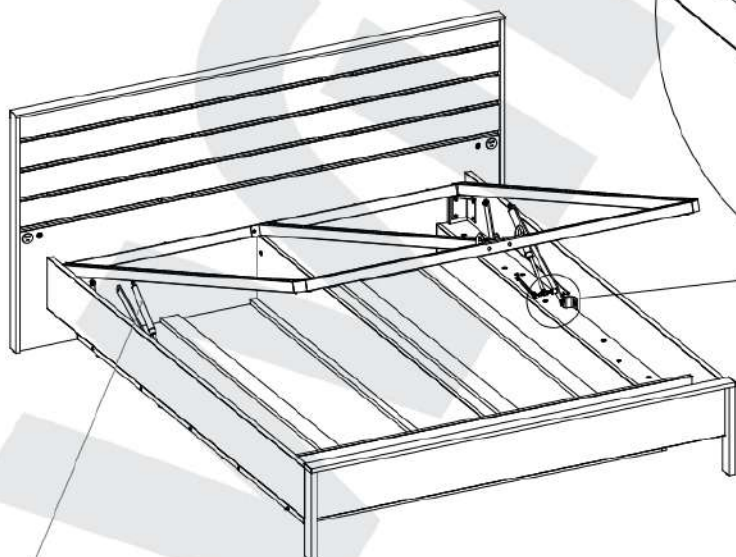

PB-037-05-037-1000

56



4x

10_31

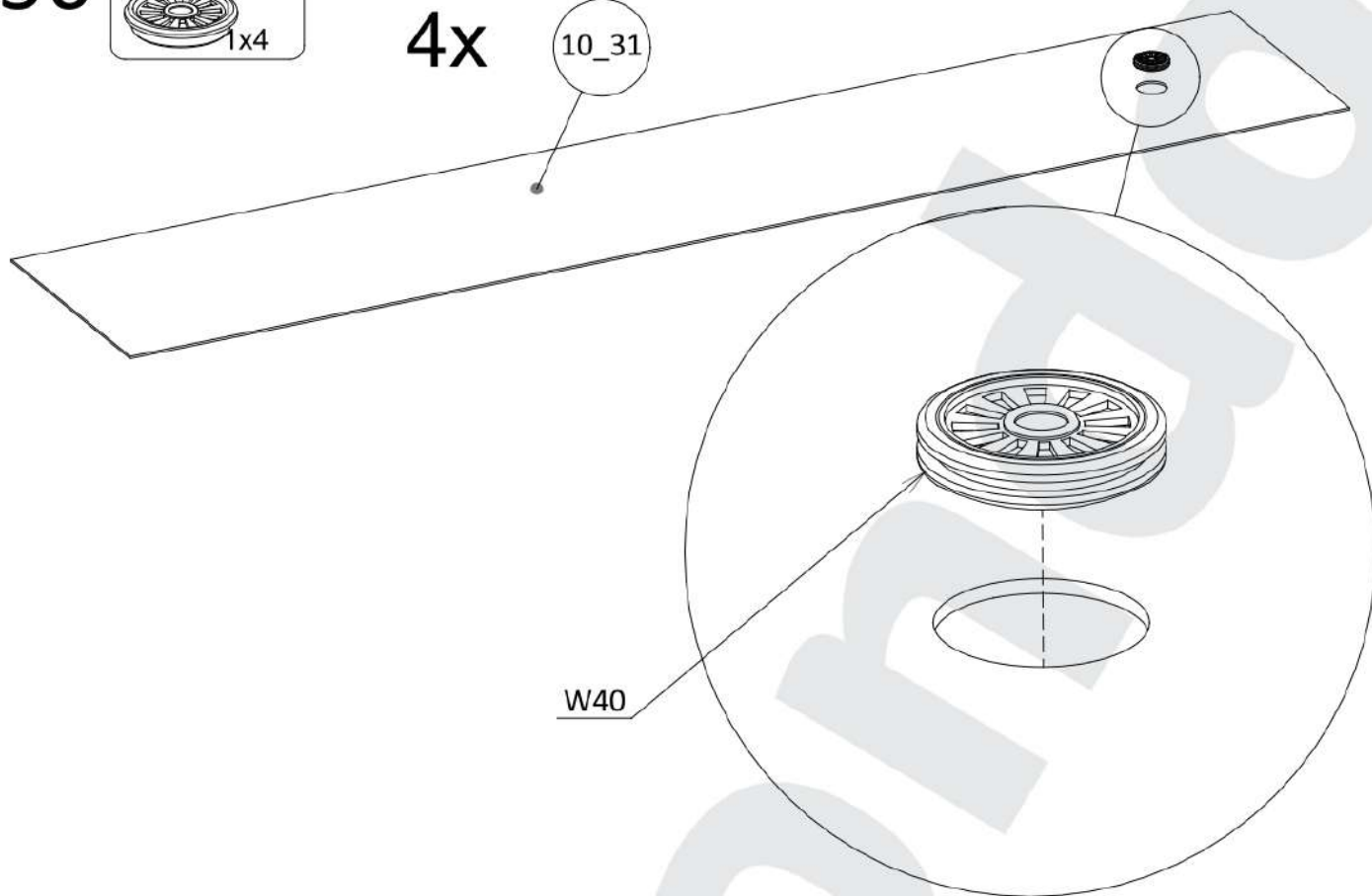

57

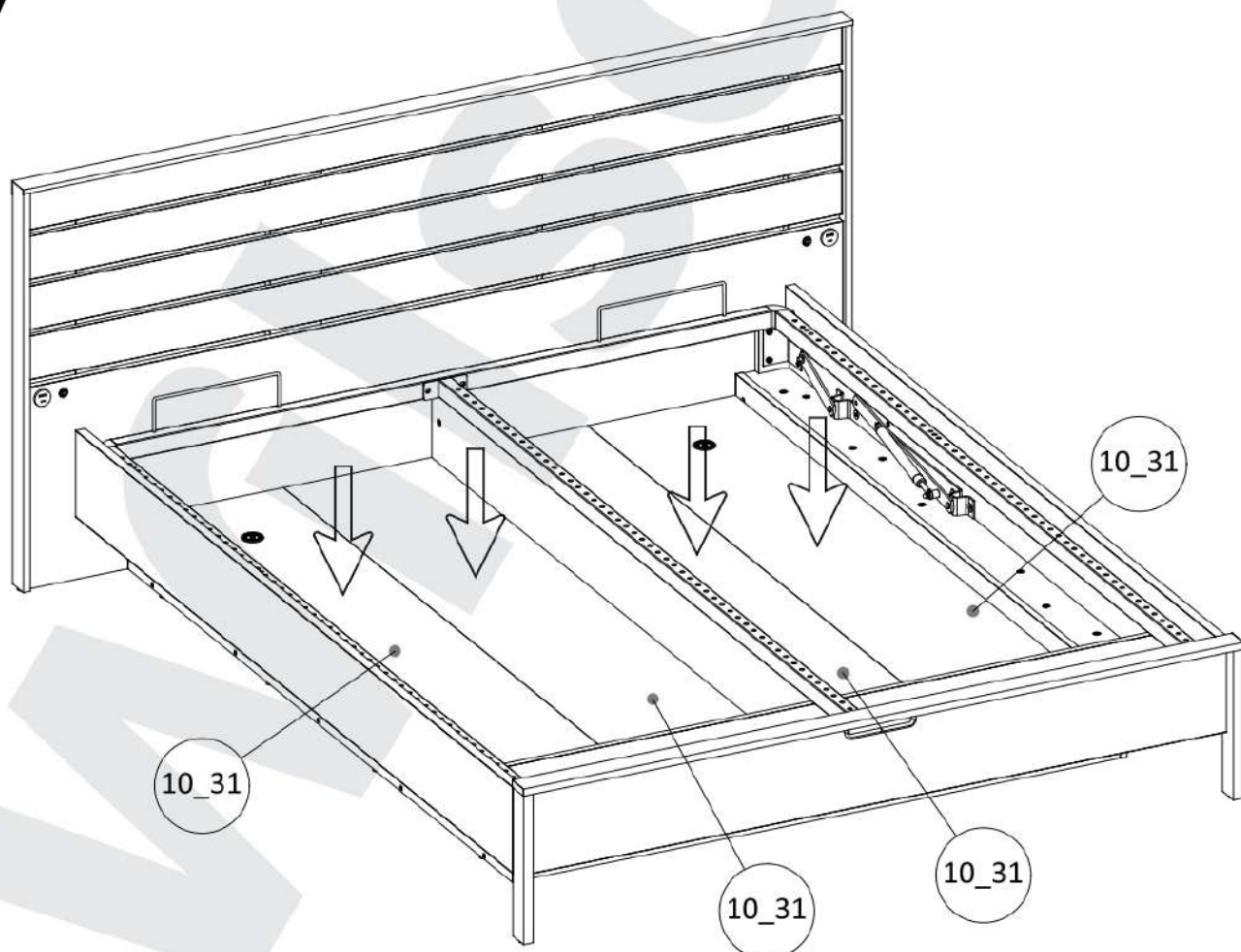

58

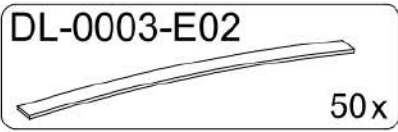

TI-00085-T08

DL-0003-E02

DL-0003-E02

TI-00085-T09

TI-00085-T08

II

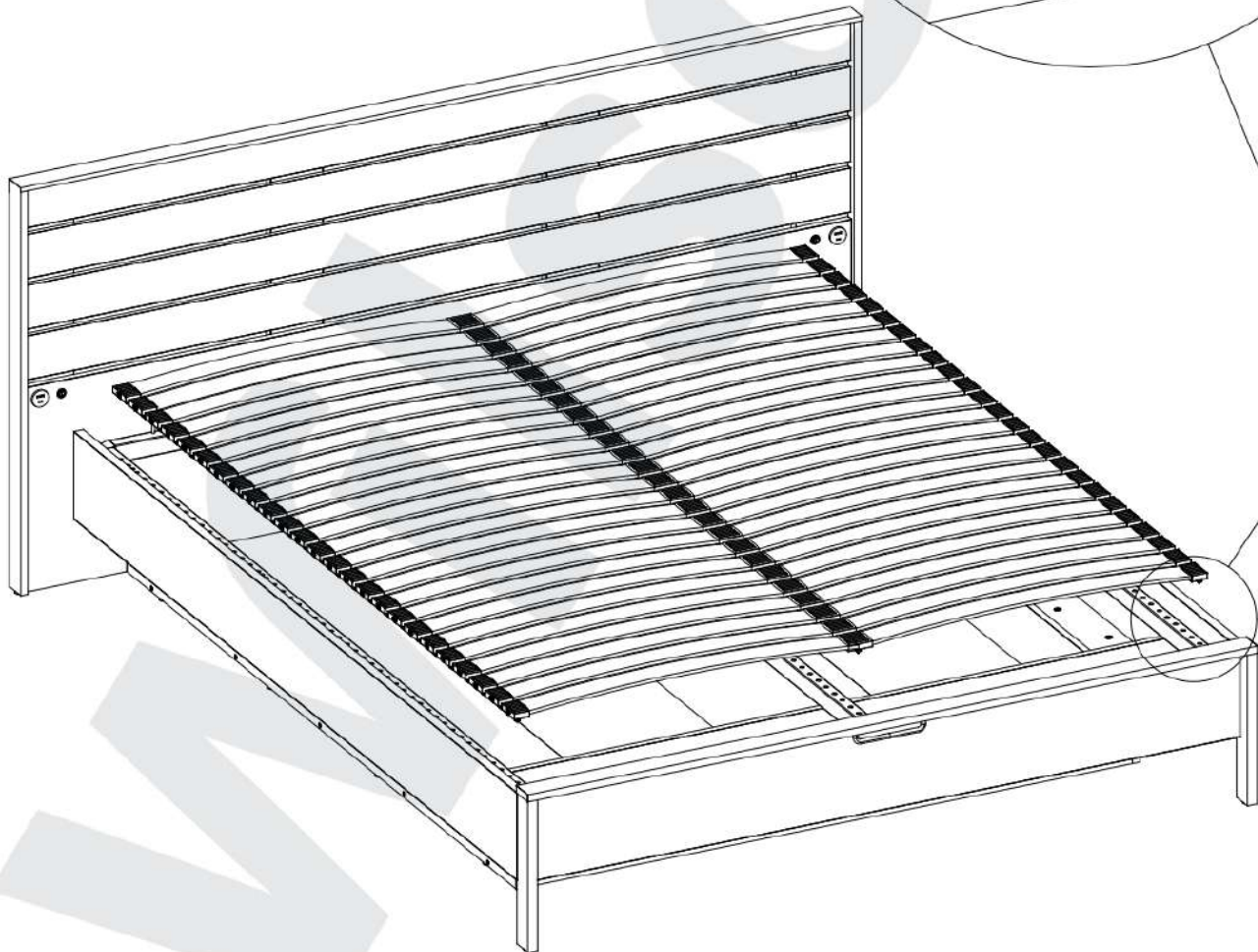

PL

Zasady użytkowania mebli:

1. Meble powinny być użytkowane zgodnie z ich przeznaczeniem.
2. Meble należy użytkować pomieszczeniach suchych, zamkniętych i zabezpieczonych przed szkodliwymi wpływami atmosferycznym oraz bezpośrednim działaniem promieni słonecznych.
3. Mebli nie należy ustawiać w odległości mniejszej niż pół metra od czynnych grzejników.
4. Wymagane jest równe wypoziomowanie, ustawienie mebli na stabilnym podłożu.
5. Sposób montażu mebli, ilość elementów i akcesoriów niezbędnych do montażu określa karta informacyjna znajdująca się w opakowaniu danego typu mebla. Chyba, że meble zgodnie z życzeniem Klienta zostały dostarczone zmontowane. W tym wypadku instrukcje montażu nie są załączane do mebli.
6. Na powierzchniach mebli nie należy stawiać przedmiotów wilgotnych.
7. Po zmontowaniu mebli należy wyregulować drzwi na prowadnicach.

Konserwacja i czyszczenie:

1. Powierzchnie wykonane z laminatu, oraz lakierowane czyścić miękką tkaniną.
2. Do pielęgnacji powierzchni nie należy stosować żadnych środków chemicznych, lub szorstkich ścierek.

Szanowny kliencie, gdyby brakowało jakiejś części, lub byłaby uszkodzona proszę to oznaczyć na instrukcji montażowej i przesłać razem z reklamacją. Jeżeli uszkodzony element będzie zamontowany na stałe reklamacja nie będzie uznana.

CZ

Základy používání nábytku

1. Nábytek by měl být používán k určenému účelu.
2. Nábytek by měl být používán v místnostech suchých, uzavřených a chráněných před škodlivými povětrnostními vlivy a před přímým slunečním zářením.
3. Nábytek by neměl být postaven na méně než půl metru před aktivními radiátory.
4. Požadovane je umístění nábytku na stabilním, vyrovnaném povrchu.
5. Návod na montáž nábytku počet součástí a příslušenství nezbytného k montáži uveden na informačním listu, nacházejícím se v obalu určeného nábytku. V případě že na pání zákazníka nábytek byl dodán smontovaný návod k montáži se nepřipojuje.
6. Na povrch nábytku nepokládajte vlhké předměty.
7. Po smontování nábytku seřdit (vyrovnat) dveře pomocí kolejniče.

Údržba a čištění:

1. Povrchy z lamina a lakované čistit měkkým hadříkem.
2. K údržbě povrchu nepoužívejte žádné chemické látky ani hrubé hadříky.

Vážný zákazník, v případě že chybí některé části nebo jsou poškozené, označte je v montážních instrukcích a zašlete společně s reklamací. Pokud poškozená část bude na pevně smontována, nebude se na ni vztahovat reklamacie.

DE

Regel der Möbelbenutzung:

1. Die Möbel sollten entsprechend ihrer Bestimmung verwendet werden.
2. Die Möbel sollten in trockenen, geschlossenen und gegen den schädlichen Witterungseinfluss sowie die direkte Wirkung der Sonnenstrahlen geschützten Räumen benutzt werden.
3. Die Möbel sollen von den tätigen Heizkörpern mindestens ein halbes Meter entfernt werden.
4. Es ist erforderlich, dass der Grund, wo die Möbel stehen, gut nivelliert und stabil ist.
5. Die Art und Weise der Montage, Anzahl der Bauteile und die Ausstattung, die für die Montage unentbehrlich ist, bestimmt die Infokarte, die sich in der Verpackung des jeweiligen Möbelstückes befindet. Es sei den, die Möbel wurden nach dem Wunsch des Kunden im zusammengebauten Zustand geliefert. In einem solchen Fall werden die Montageanweisungen nicht hinzugefügt.
6. Auf der Oberfläche der Möbel darf man keine feuchten Gegenstände stellen.
7. Nach dem Zusammenbauen der Möbel sollte man die Tür an den Führungen richten.

Wartung und Sauberhaltung:

1. Flächen aus Laminat und lackierte Oberflächen sind mit einem weichen Tuch zu reinigen.
2. Zur Pflege der Oberfläche sollten keine chemischen Mittel oder borstigen Wischtücher verwendet werden.

Sehr geehrter Kunde, sollte ein Bauteil fehlen oder geschädigt werden, kennzeichnen Sie dies bitte auf der Montageanweisung und zusammen mit dem Beschwerdebrief senden. Sollte das geschädigte Teil fest angebaut werden, wird die Beanstandung nicht anerkannt.

EN

Terms of use furniture:

1. Furniture should be used for their intended purpose.
2. Furniture should be used in dry, closed rooms, protected from an adverse weather and a direct sunlight.
3. Furniture should not be set at a distance of less than half a meter of active radiators.
4. The equal leveling is required and the need to set furniture on the stable base.
5. The information card, contained in the packaging of the given type of furniture defines the assembling method of furniture, quantity of components and accessories necessary for assembly, except when furniture were delivered assembled according to the customer wish. Assembly instructions are not attached to furniture in this case.
6. Wet objects should not be placed on surfaces of furniture.
7. Doors on tracks should be adjusted after assembling furniture.

Maintenance and cleaning:

1. Surfaces made of the laminate and lacquered surfaces clean with a soft cloth.
2. Any chemicals or rough rubbers should not be used for the surfaces care.

Dear customer, if anything part is missing or damaged, mark it on the assembly instruction and sent to together with the claim, please. If the damaged item is permanently mounted, than the complaint will not be considered.

SK

Základy používania nábytku:

1. Nábytok používajte k určenému účelu.
2. Nábytok používajte v suchej, uzatvorenej a chránenej pred škodlivými poveternostnými vplyvmi miestnosti, chráňte pred priamym slnečným žiarením.
3. Nábytok by nemal byť postavený na menej než pol metra pred aktívnymi radiátormi.
4. Nábytok postavte na stabilný vyrovnaný povrch.
5. Návod na montáž nábytku počet súčasti a príslušenstva nevyhnutného k montáži, je uvedený na informačnom liste nachádzajúcom sa v obale určeného nábytku. V prípade, že na pranie zákazníka bol nábytok dodaný zmontovaný, nebude návod súčasťou balenia.
6. Na povrch nábytku, nepokladajte vlhke predmety.
7. Po zmontovaní nábytku nastavte dvere pomocou kolejniče.

Údržba a čistenie:

1. Povrchy z lamina a lakované čistiť mäkkou handričkou.
2. Pre údržbu povrchu nepoužívajte žiadne chemické látky ani hrubé handričky.

Vážný zákazník, v prípade, že chýbajú niektoré časti, alebo sú poškodené, označte ich v montážnych instrukciách a pošlite spoločne s reklamáciou, pokiaľ poškodená časť bude napevno zmontovaná, nebude sa ňu reklamácia vzťahovať.

RU

Правила ухода за мебелью

1. Мебелью необходимо пользоваться в соответствии с ее функциональным назначением.
2. Мебель должна эксплуатироваться в сухих закрытых и защищенных от воздействия атмосферных условий и прямых солнечных лучей помещениях.
3. мебель нельзя устанавливать ближе 50 см от отопительных приборов.
4. Требуется установка мебели по уровню на стабильной поверхности.
5. Способ монтажа мебели количество элементов необходимых для монтажа определяет инструкция находящаяся в упаковке данного типа мебели. В случае если мебель по желанию клиента была поставлена собранной инструкция монтажа не прилагается.
6. Нельзя ставить на мебель влажные предметы.
7. После монтажа мебели необходимо отрегулировать дверь на петлях.

Рекомендации по уходу и очистке:

1. Поверхности из ламината и покрытые лаком очищать мягкой тканью.
2. Для ухода за поверхностью не использовать никаких химических средств или шероховатых тряпок.

Уважаемы Клиент в случае если не хватает какого-нибудь элемента или он поврежден просим обозначить его на инструкции монтажа и отправить нам в месте с претензией. Если поврежденный элемент будет установлен-претензия не будет признана.

FR

Règles d'utilisation du mobilier :

1. Le mobilier doit être utilisé conformément à sa destination.
2. Le mobilier doit être utilisé dans un endroit sec, fermé et protégé des influences atmosphériques néfastes et la lumière directe du soleil.
3. Les meubles ne doivent pas être placés à moins d'un demi-mètre de radiateurs actifs.
4. Une mise à niveau est nécessaire, il faut placer le meuble sur une surface stable.
5. La méthode de montage des meubles, le nombre d'éléments et d'accessoires nécessaires au montage sont définis dans la fiche d'information incluse dans l'emballage d'un type de meuble donné, sauf si les meubles ont été livrés montés conformément à la demande du client.
Dans ce cas, les notices de montage ne sont pas fournies avec les meubles.
6. Ne posez pas d'objets humides sur les surfaces des meubles.
7. Après avoir monté le meuble, ajoutez les portes sur les guides.

Entretien et nettoyage :

1. Les surfaces stratifiées et vernies doivent être nettoyées avec un chiffon doux.
2. Pour l'entretien des surfaces, n'utilisez pas de produits chimiques ou des chiffons abrasifs.

Cher client, si une pièce est manquante ou endommagée, veuillez l'indiquer dans la notice de montage et envoyer avec la réclamation. Si l'élément défectueux est installé de façon permanente, la réclamation ne sera pas acceptée.

SE

Regler för möblernas underhåll och rengöring:

1. Möblerna ska användas för sitt avsedda ändamål.
2. Möblerna ska användas i torra, slutna utrymmen som är skyddade mot skadlig atmosfärisk påverkan och direkt solstrålning.
3. Möblerna bör inte placeras på ett avstånd som är mindre än en halv meter från värmelement.
4. Det krävs en jämn yta (med samma nivå), och placering av möblerna på ett stabilt underlag.
5. Monteringsätt av möbler, antal komponenter (delar) och tillbehör som är nödvändiga för montage anges på informationskort som finns i förpackning för enskild möbeltyp. Om möblerna inte har levererats monterade på kundens begäran, i sådant fall är monteringsanvisningen inte bifogad möblerna.
6. På möblernas ytor bör man inte ställa våta föremål.
7. Efter möblernas montering måste skåpdörrarjusteras på skenor.

Möblernas underhåll och rengöring:

1. Ytor av laminat samt målade ytor ska rengöras med en mjuk trasa.
2. För ytans underhåll får man inte använda några kemikaliskamedel eller slipdyna.

Bästa kund, om det saknas någon del, eller om den är trasig, vänligen markera det på installationsinstruktionen och skickadett tillsammans med ansökan. Om den skadade delen kommer att användas som monterad permanent, kommer klagomålet inte att beaktas.

HR

Način uporabe namještaja

1. Namještaj koristiti sukladno namjeni.
2. Namještaj mora se koristiti u suvim i zatvorenim prostorijama osiguranim od štetnih vremenskih uvjeta i izravnog sunčevog zračenja.
3. Namještaj ne može se stavljati na razmaku od najmanje 50 cm od uključenih grejačkih uređaja.
4. Površina na koju stavljate namještaj mora biti nivelirana i stabilna.
5. Način montaže, broj dijelova i akcesorija potrebnih za montažu određuju upute za montažu namještaja koje se nalazi unutar ambalaze. Ako se kupcu namještaj isporučuje montiran, upute nisu uključene.
6. Ne stavljati vlažne predmete na površinu namještaja.
7. Nakon montaže namještaja regulirati vrata na vodilicama.

Održavanje i čišćenje:

1. Površine od laminata i lakirane čistiti mekom krpom.
2. Za održavanje površina ne koristiti kemijska sredstva ili abrazivne krpe.

Poštovani kupci, u slučaju nedostatka ili oštećenja bilo kojeg dijela, označite ovaj element u uputama za montažu i pošaljite zajedno s reklamacijom, ako je oštećeni element trajno montiran, reklamacija neće se razmatrati.

SRB

Način korišćenja nameštaja

1. Nameštaj treba da bude korišćen u skladu sa namenom.
2. Nameštaj mora da bude korišćen u suvim i zatvorenim prostorijama zaštićenim od nepovoljnih vremenskih uslova i direktne sunčeve svetlosti.
3. Nameštaj ne može da bude postavljen na udaljenosti od najmanje 50 cm od uključenih uređaja za grejanje.
4. Nameštaj mora da bude postavljen na ravnu i stabilnu podlogu.
5. Način postavljanja, broj delova i akcesorija neophodnih za postavljanje definiše uputstvo za postavljanje nameštaja koje se nalazi unutra pakiranja. Ovo uputstvo se ne odnosi na nameštaj koji je prema želji kupca isporučen u gotovom stanju, u ovom slučaju uputstvo nije uključeno u set nameštaja.
6. Nemojte stavljati vlažne predmete na površinu nameštaja.
7. Nakon postavljanja nameštaja podesite vrata na vodilicama.

Održavanje i čišćenje:

1. Površine od laminata i lakirane čistite mekanom tkaninom.
2. Za održavanje površina nemojte koristiti hemijska sredstva ili abrazivne krpe.

Poštovani kupci, u slučaju nedostatka ili oštećenja bilo kojeg dela, označite ovaj element u uputstvu za postavljanje i pošaljite zajedno sa reklamacijom. Ako je oštećen element trajno postavljen, reklamacija neće biti razmatrana.

HU

Használati útmutató

1. A bútort a rendeltetésüknek megfelelően kell használni.
2. A bútort az időjárási körülményektől védett, zárt, szárazhelyiségekben kell használni, ahol nincsenek kitéve a napsugárkövetlen hatásának.
3. A bútort a működő fűtőberendezésekhez ne helyezzük fel méternél kisebb távolságra.
4. Fontos, hogy a bútort stabil alappal, szintbe állítva használják.
5. A bútór összeszereléshez szükséges ismereteket, az elemek mennyiségét, és az összeállításához szükséges tartozékok listáját az összeszerelési útmutató tartalmazza, mely az adott típusú bútór csomagolásában található. Abban az esetben, ha a bútór a Vevő kérésének megfelelően összeszerelve kerül leszállításra, a bútóhoz nincs mellékelve összeszerelési útmutató.
6. A bútórok felületére ne helyezzünk nedves tárgyakat.
7. A bútórok összeállítását követően be kell állítani az ajtókat a kivetőpántok segítségével.

Ápolás és tisztítás

1. A laminált és lakkozott felületeket puha ruhával tisztítsuk.
2. A felületek ápolásához ne használjunk semmilyen vegyszert, vagy durva törőkendőt.

Tisztelt Vevő, ha valamelyik bútorelem hiányozna, vagy hibásan kerülne átadásra, kérjük jelölje azt be az összeszerelési útmutatóban, és a reklamációval együtt küldje el részünkre, amennyiben a hibás elem eredeti rendeltetési helyére beszerelésre kerül, a reklamációt nem áll módunkban elfogadni.

NL

Gebruiksregels voor meubels:

1. Meubels moeten worden gebruikt waarvoor ze bedoeld zijn.
2. Meubels moeten worden gebruikt in een droge, gesloten ruimte die bescherming biedt tegen schadelijke weersinvloeden en direct zonlicht.
3. Plaats de meubels niet binnen een halve meter afstand tot een werkende radiator.
4. Meubels moeten waterpas staan op een stabiele ondergrond.
5. De montagemethode en het aantal benodigde onderdelen en accessoires voor de montage blijken uit het informatieblad in de verpakking. Dit geldt niet wanneer de meubels naar wens van de klant gemonteerd zijn geleverd. In dat geval ontvangt u geen handleiding.
6. Plaats geen vochtige voorwerpen op de meubels.
7. Na montage van de meubels moeten de deuren op de geleiders worden afgesteld.

Onderhoud en reiniging:

1. Oppervlakken van laminaat en met een laklaag afnemen met een zachte doek.
2. Gebruik voor het onderhoud van de oppervlakken geen chemische middelen of ruwe doeken.

Indien er een onderdeel ontbreekt of beschadigd is, geef dit dan aan op de montagehandleiding en stuur deze samen met uw klacht op. Als het beschadigde onderdeel permanent wordt gemonteerd, wordt de klacht niet ingewilligd.