

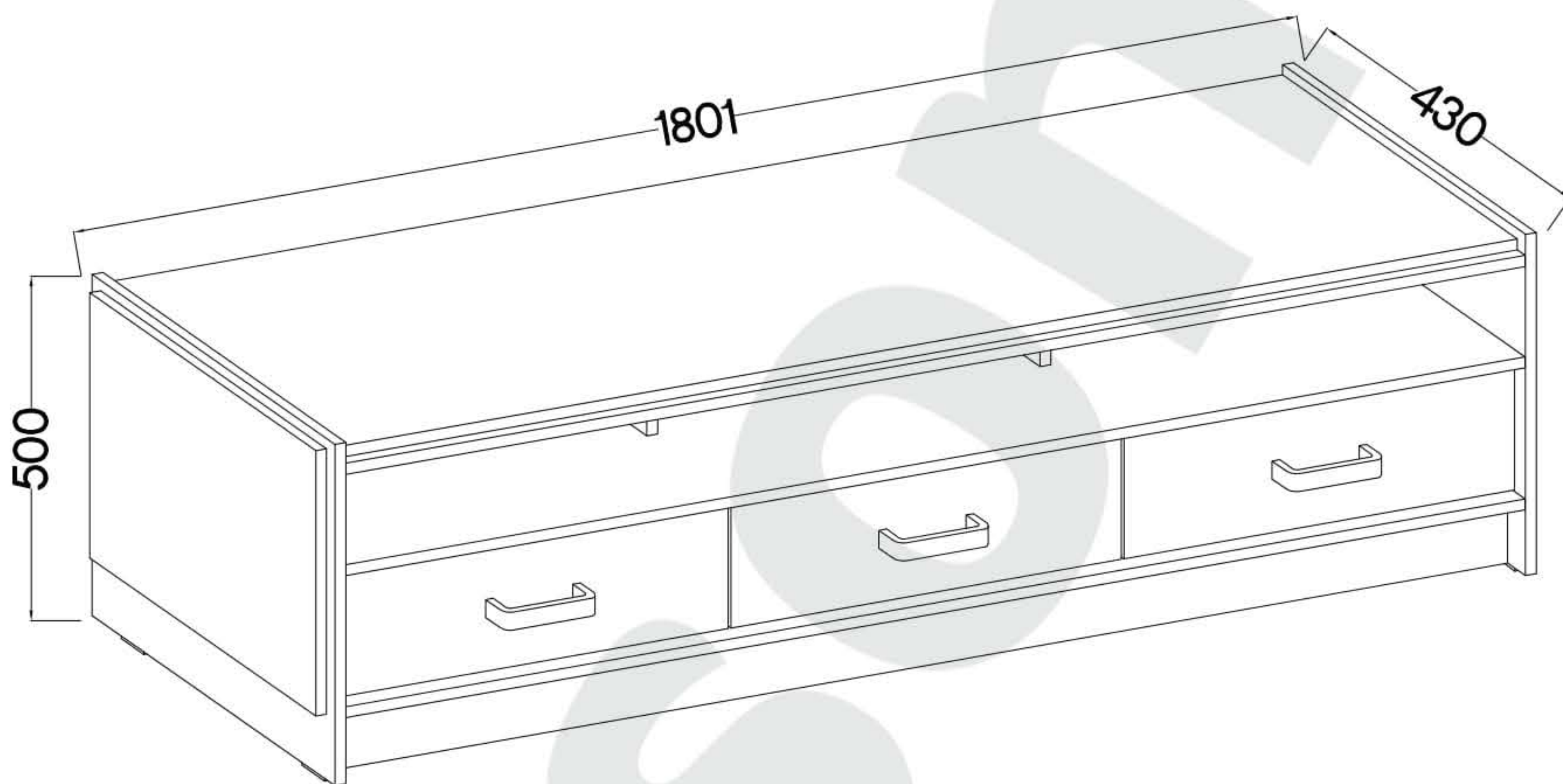









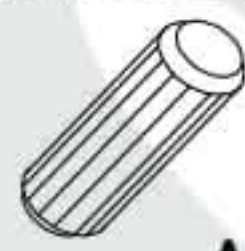







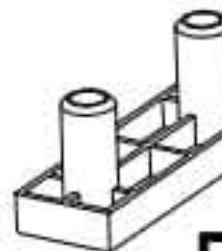

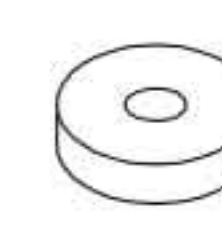
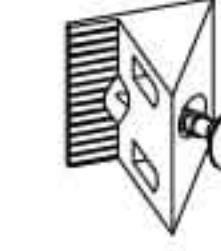
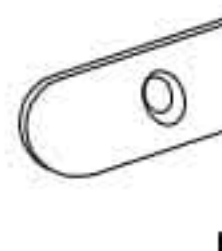

120 min

TYP 310

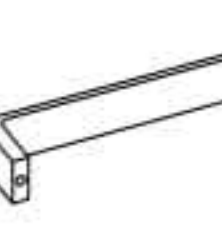
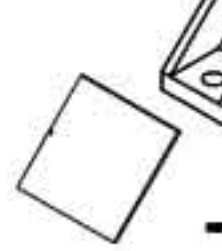

†8x30mm  A	†8x60mm  A2	†8x20mm  A4	6,4 x 50mm  B	†6x42mm  B2
42	2	4	4	6

†15/12mm  C	†12/10mm  C5	L=20mm  D2	cza.  E	art.  E	6.5x48x16  F2	†15x5mm  F4	27/310mm  I4	†20/8mm  J14	 L	 L2
22	6	28	14	4	4	2	3	4	22	4
†6,3x13mm  M2	†6.3x20mm  M3	 O	 O1	†4.0x16mm  P1	†3.0x20mm  P7	†3.5x25mm BLACK  P25	L=128mm  S	 T3	M4x22mm  U	M4x9mm  U1
8	4	1	1	2	26	11	3	1	6	6

ISM-KIA-003

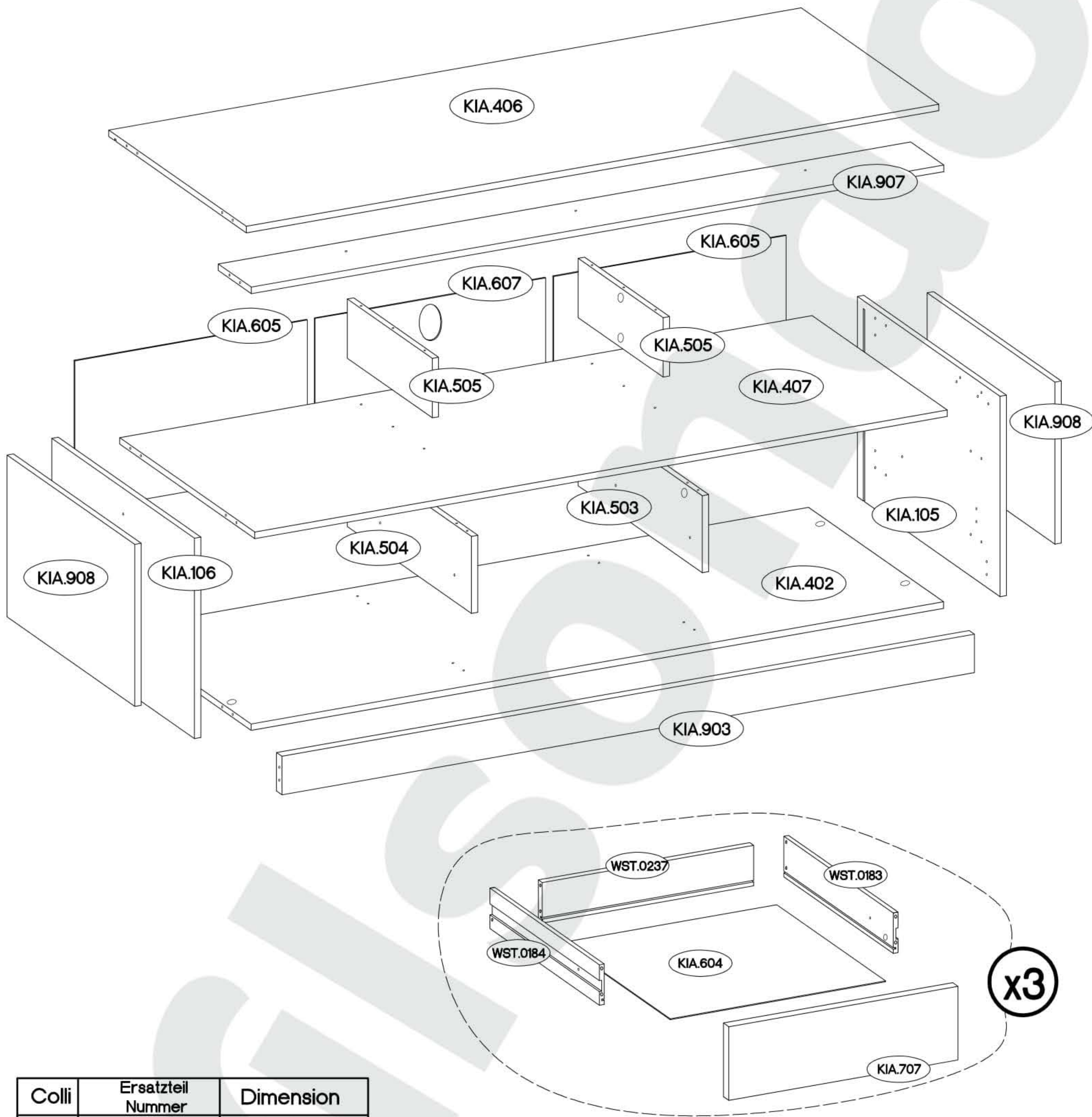



Colli	Ersatzteil Nummer	Dimension
1/2	KIA.105	495x430x16
	KIA.106	495x430x16
	KIA.503	190x374x16
	KIA.504	190x374x16
	KIA.505 x2	147x256x16
	KIA.603 x3	540x327x2,5
	KIA.605 x2	372x583x2,5
	KIA.607	372x578x2,5
	KIA.908 X2	385x400x16
	WST.0183 x3	330x100x12
	WST.0184 x3	330x100x12
	WST.0237 x3	530x100x12

Colli	Ersatzteil Nummer	Dimension
2/2	KIA.402	1737x407x16
	KIA.406	1737x415x16
	KIA.407	1737x407x16
	KIA.707 x3	575x182x16
	KIA.903	1737x95x16
	KIA.907	1737x100x16

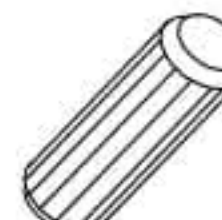

KIA.604

1

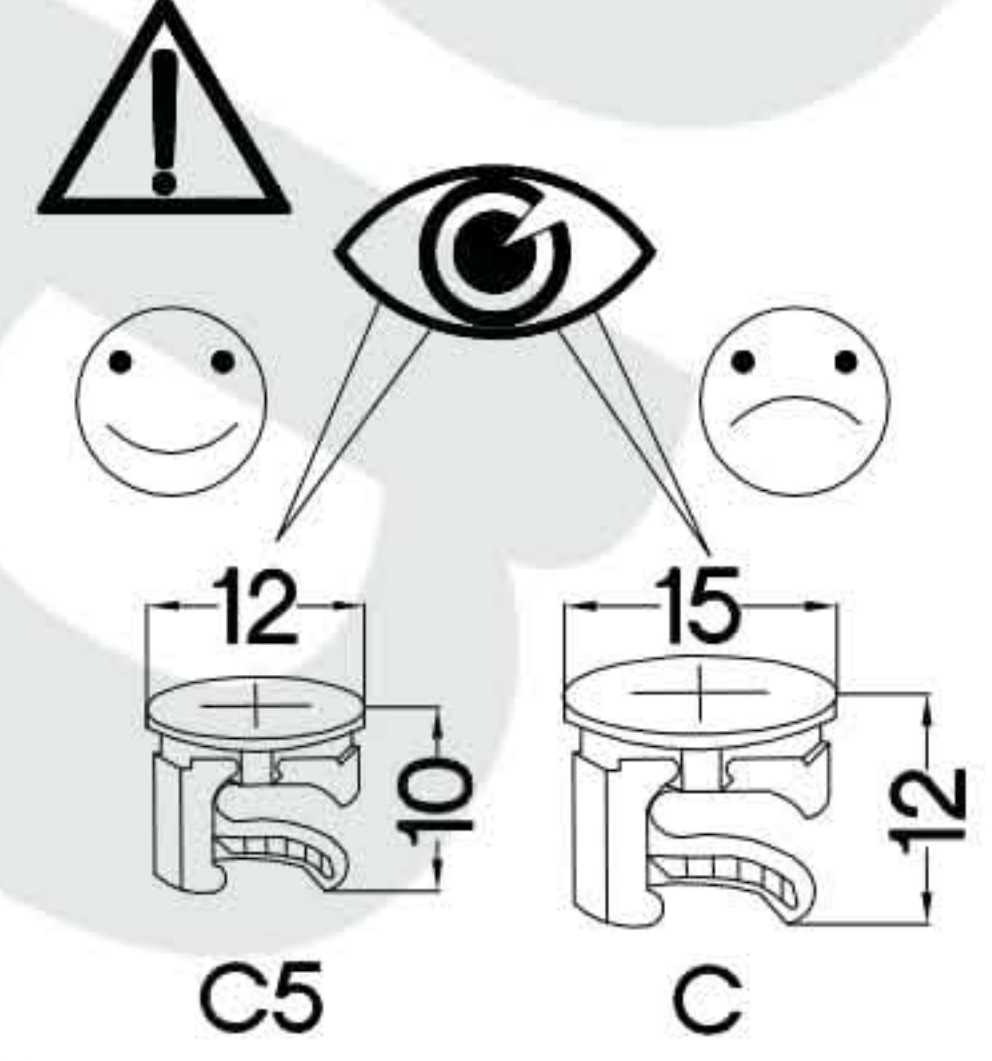
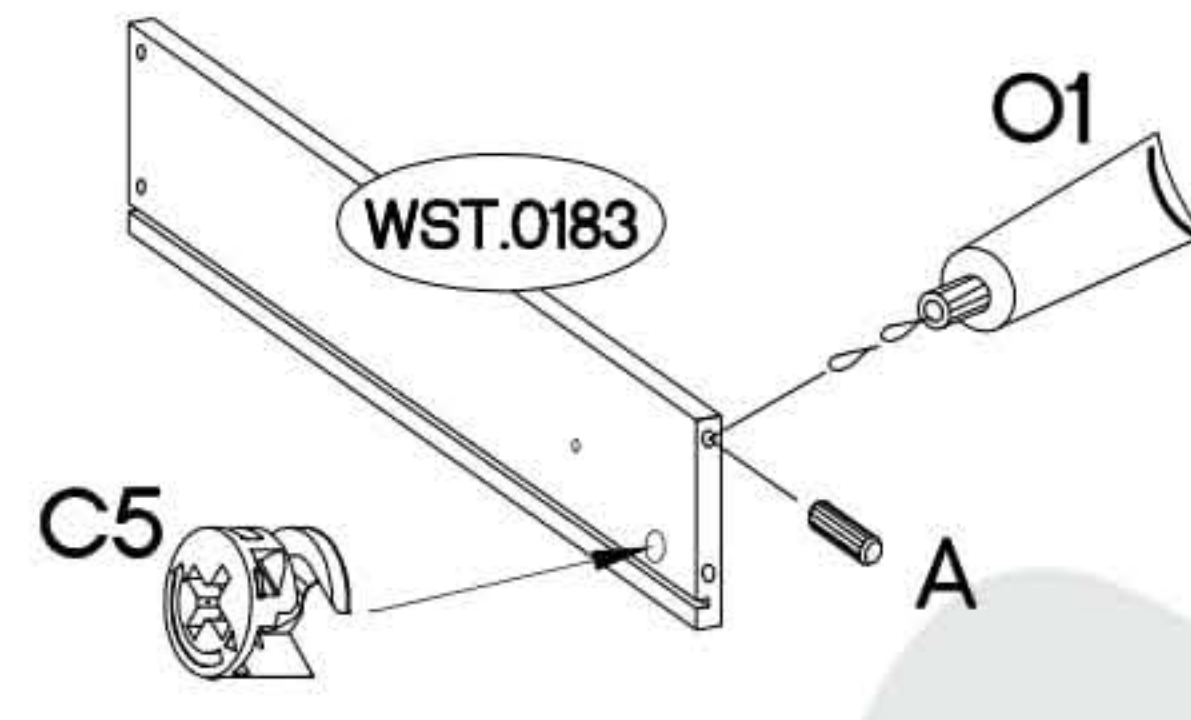
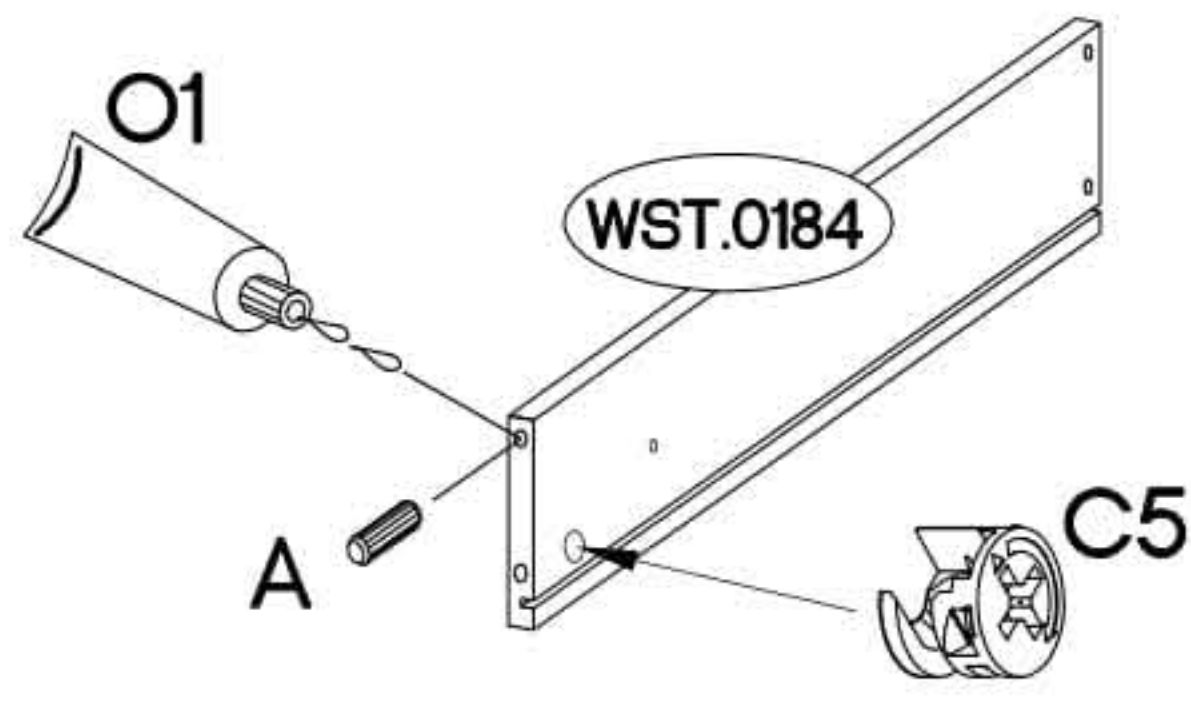
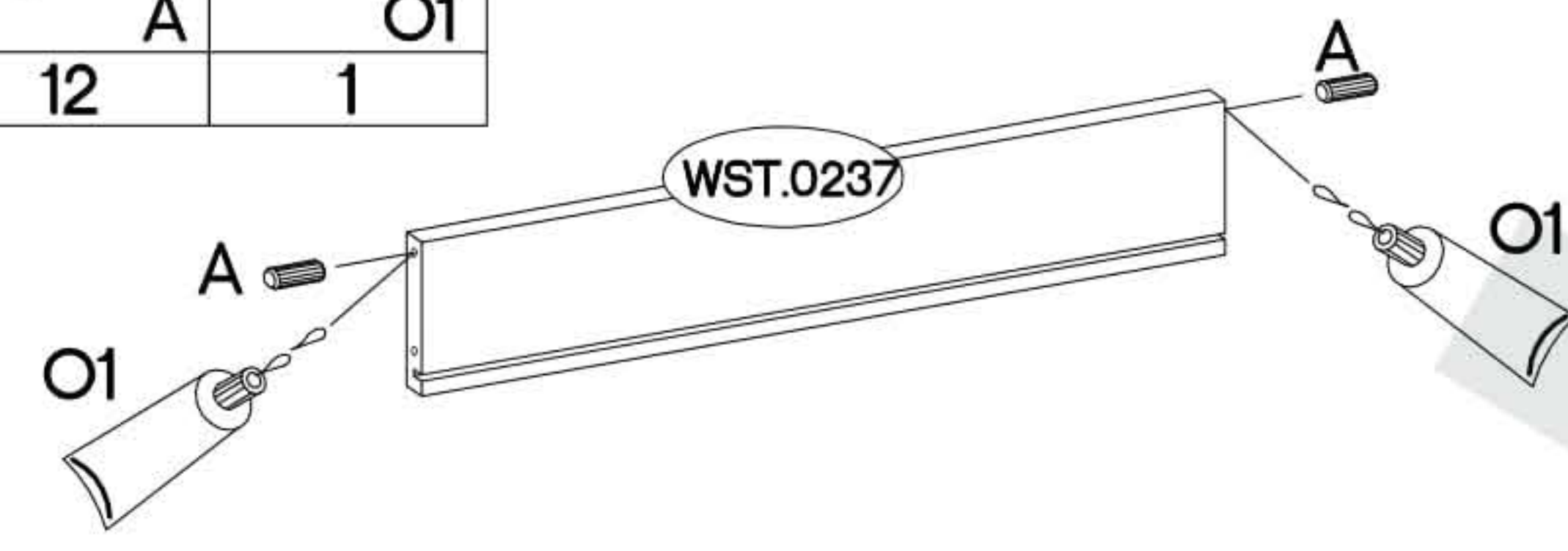

±12/10mm  C5 6	±8x30mm  A 12	 O1 1
---	--	---

x3



2

x3

±6x42mm  B2 6	 O1 1
---	--

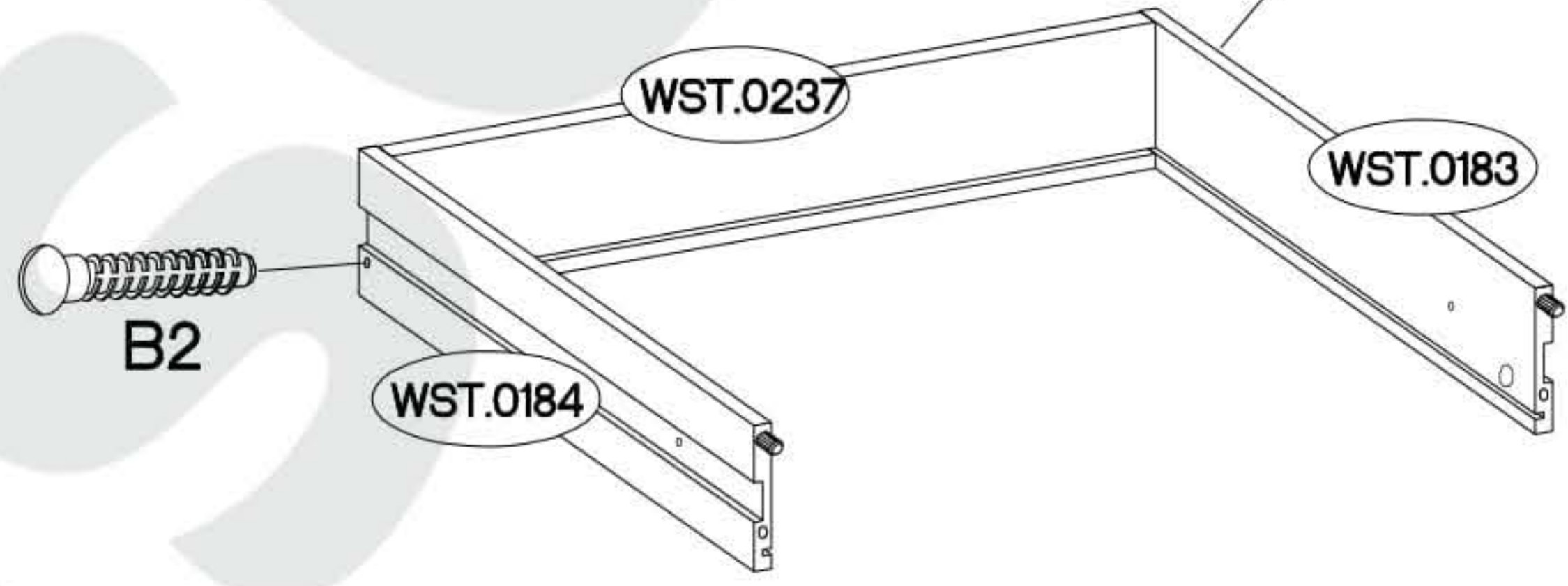
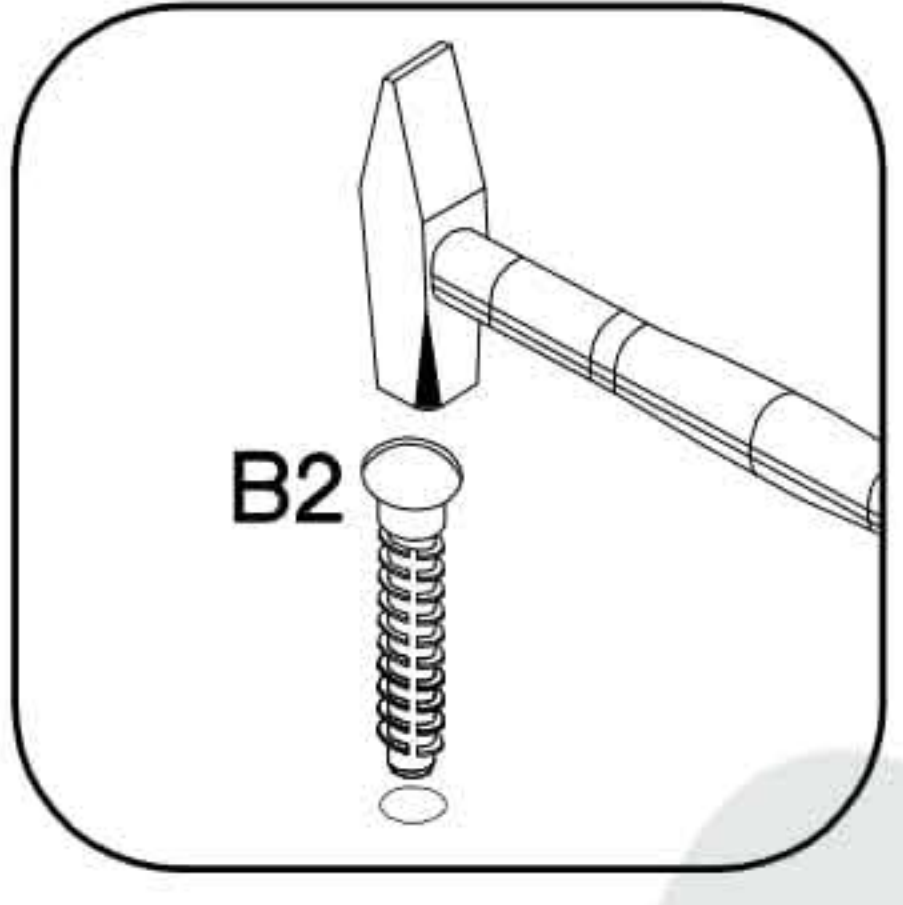
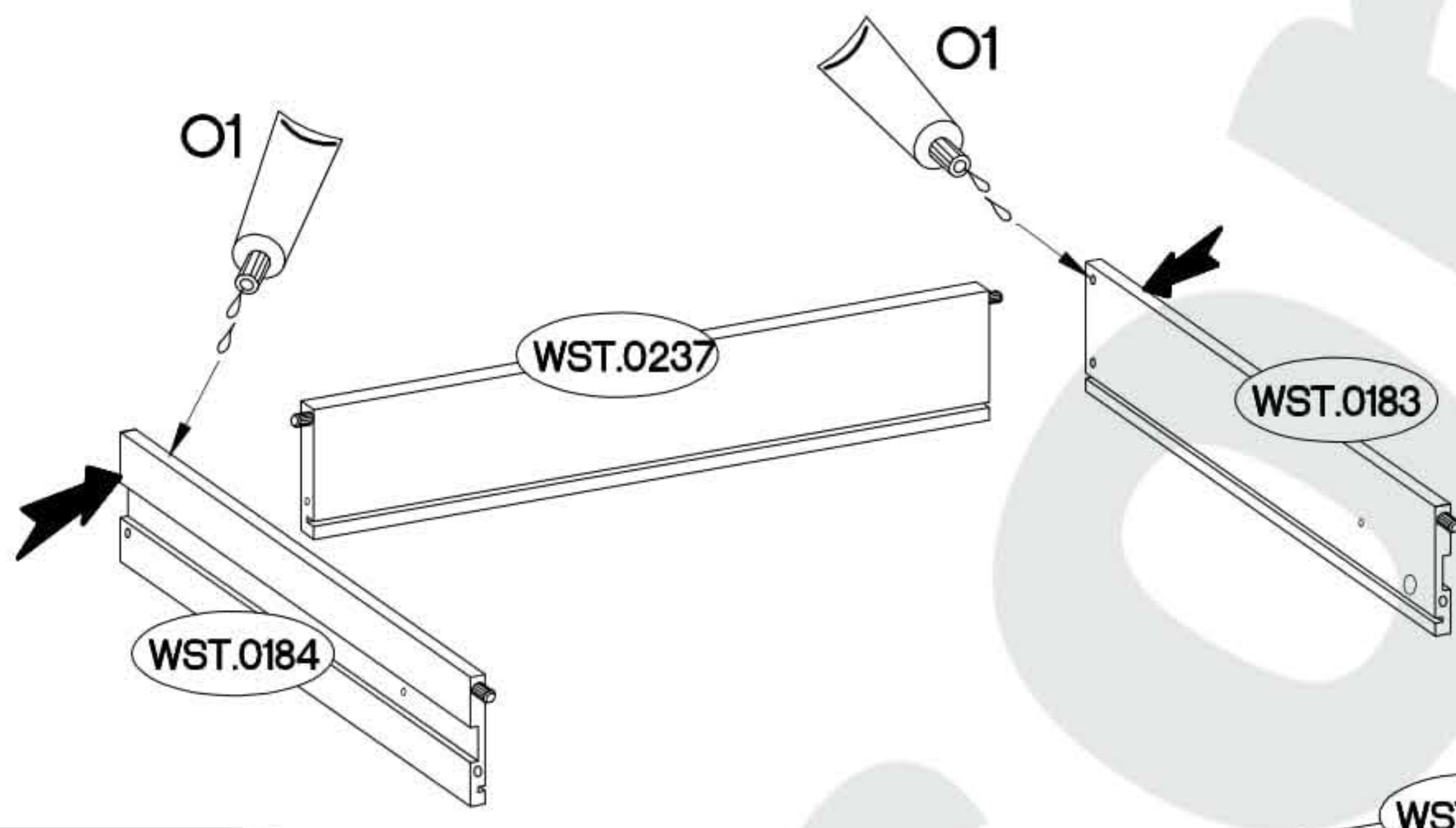

3

L=20mm  D2 6
--

x3

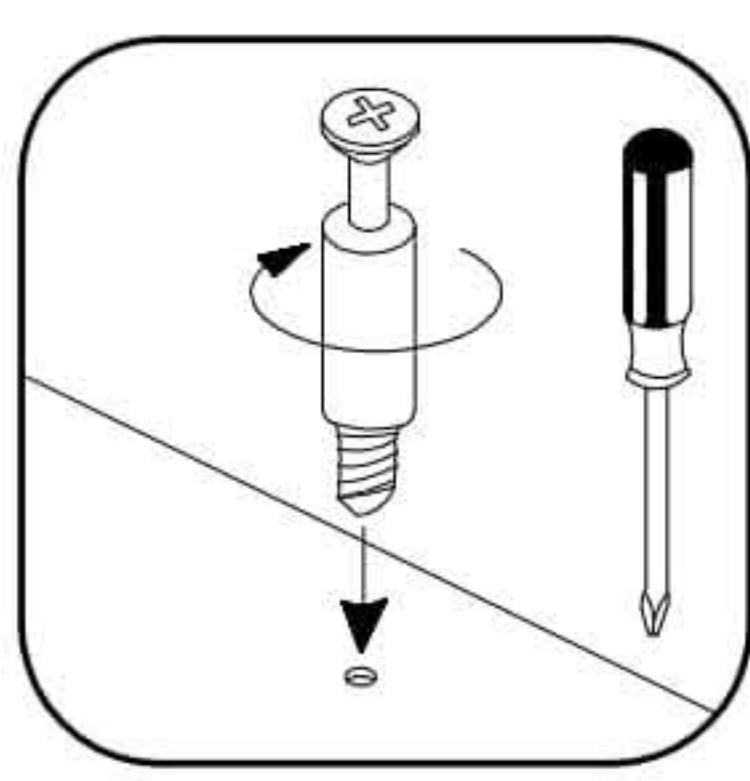
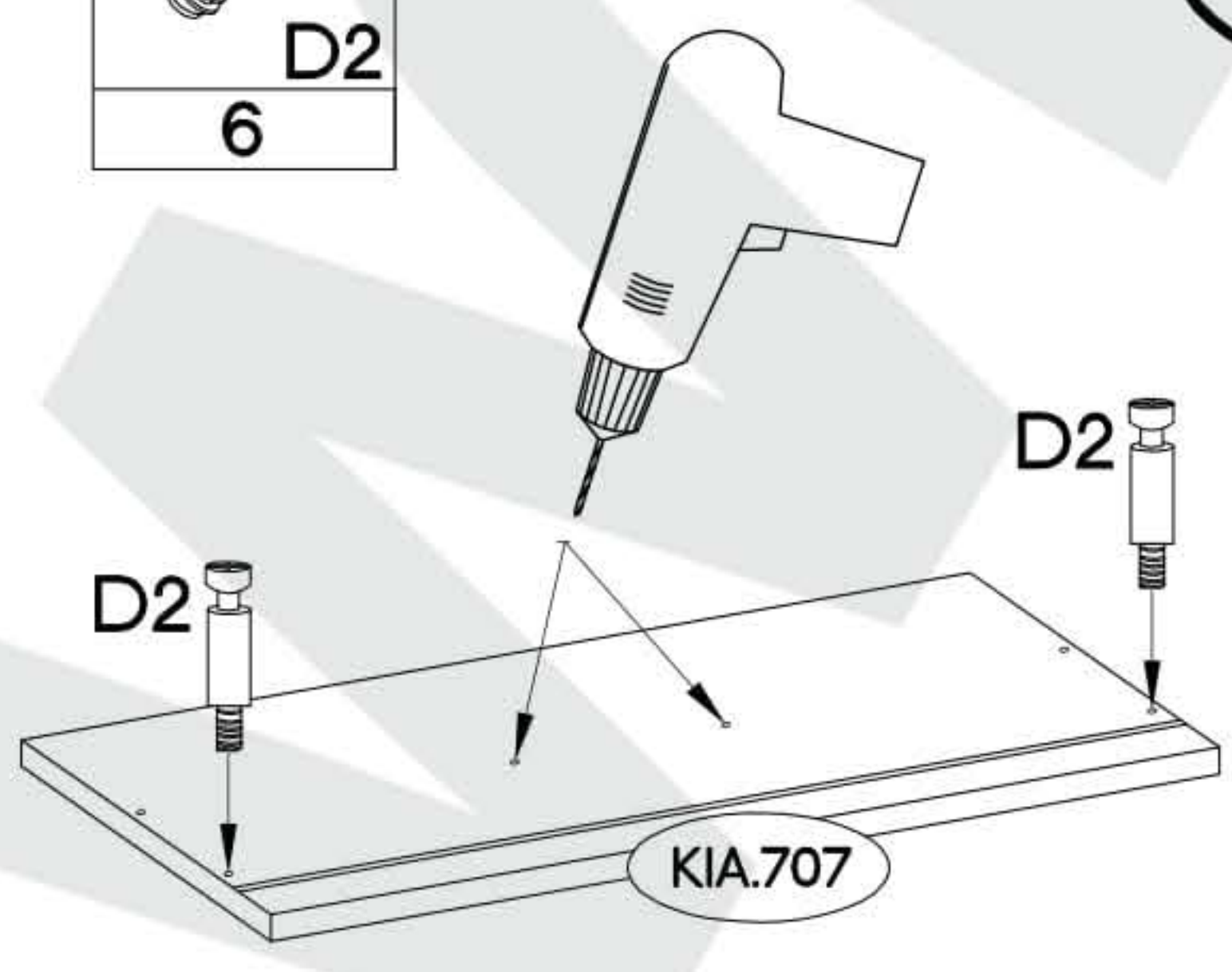
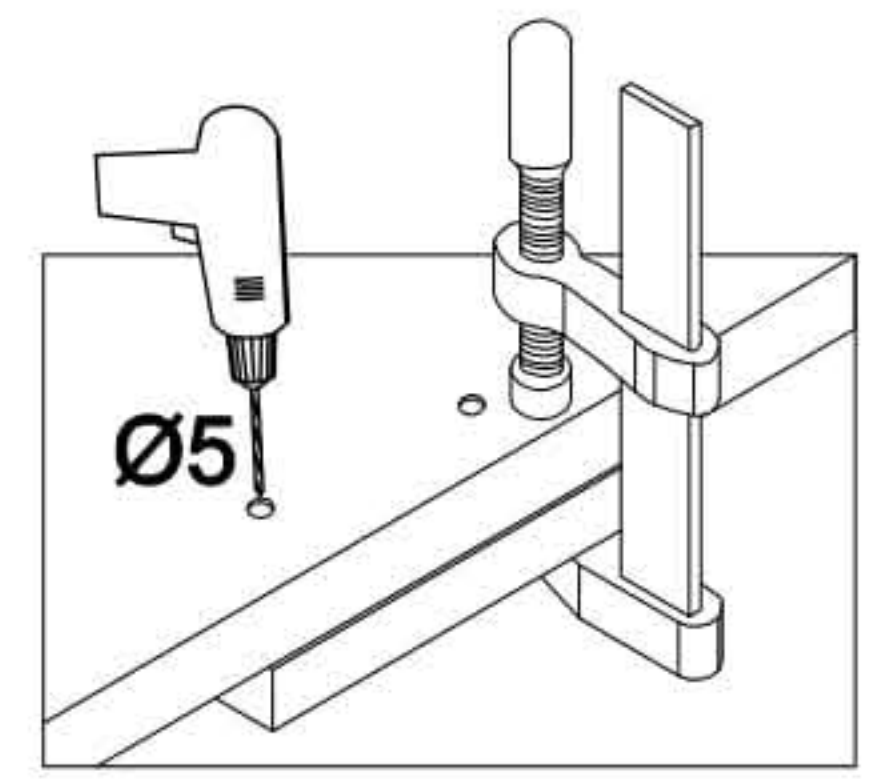



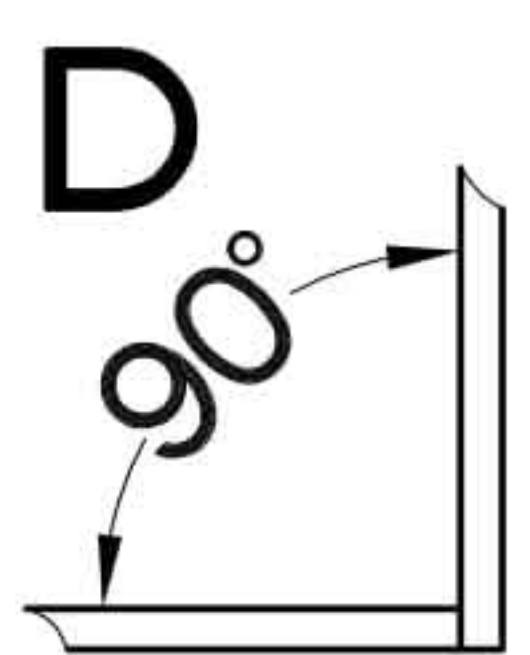
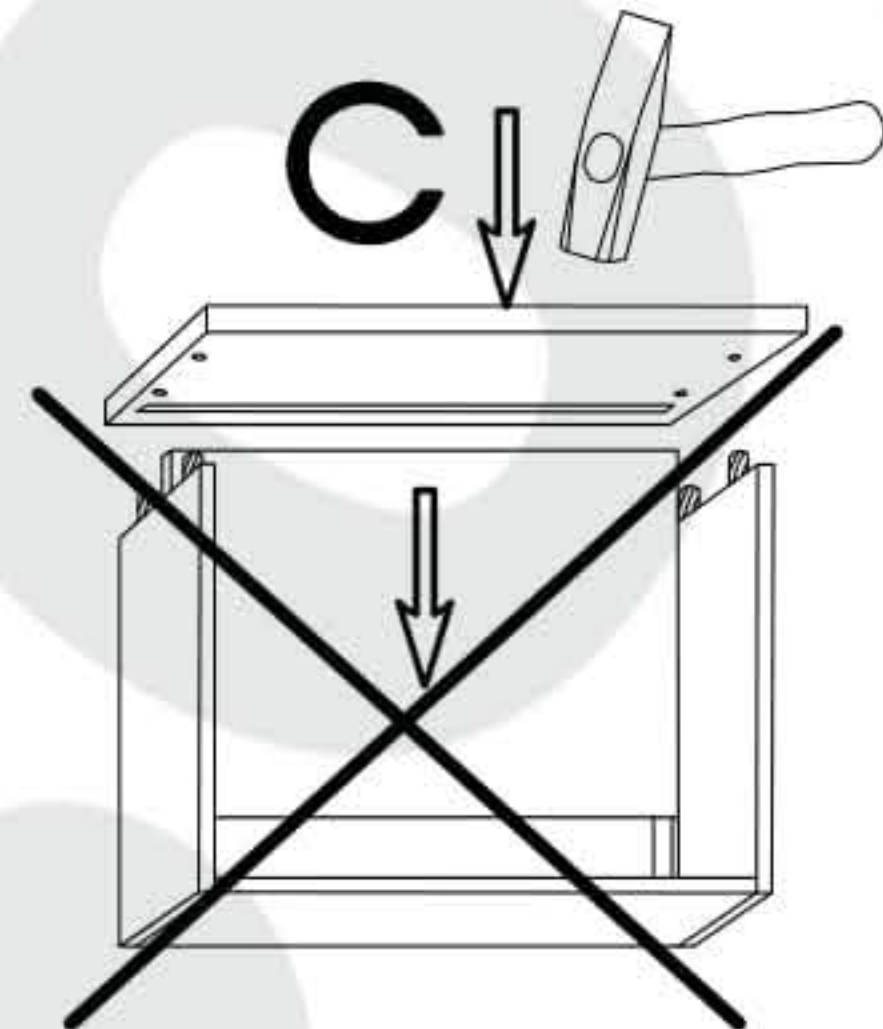
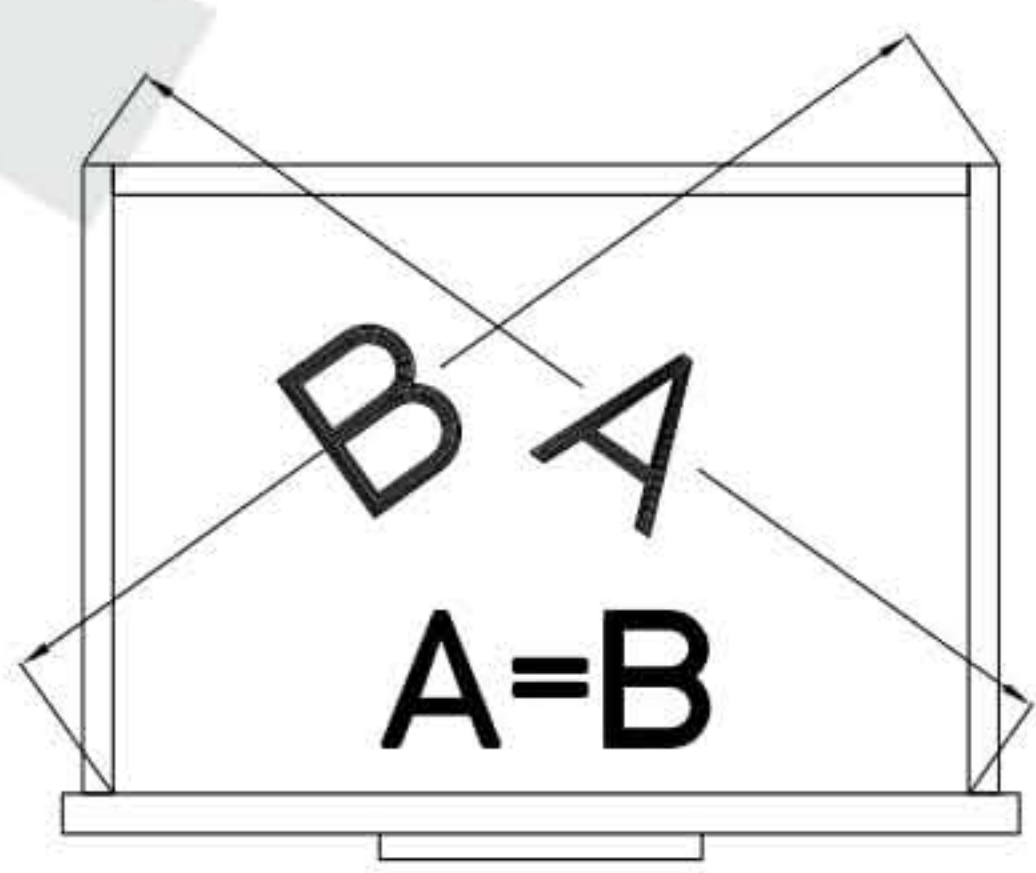
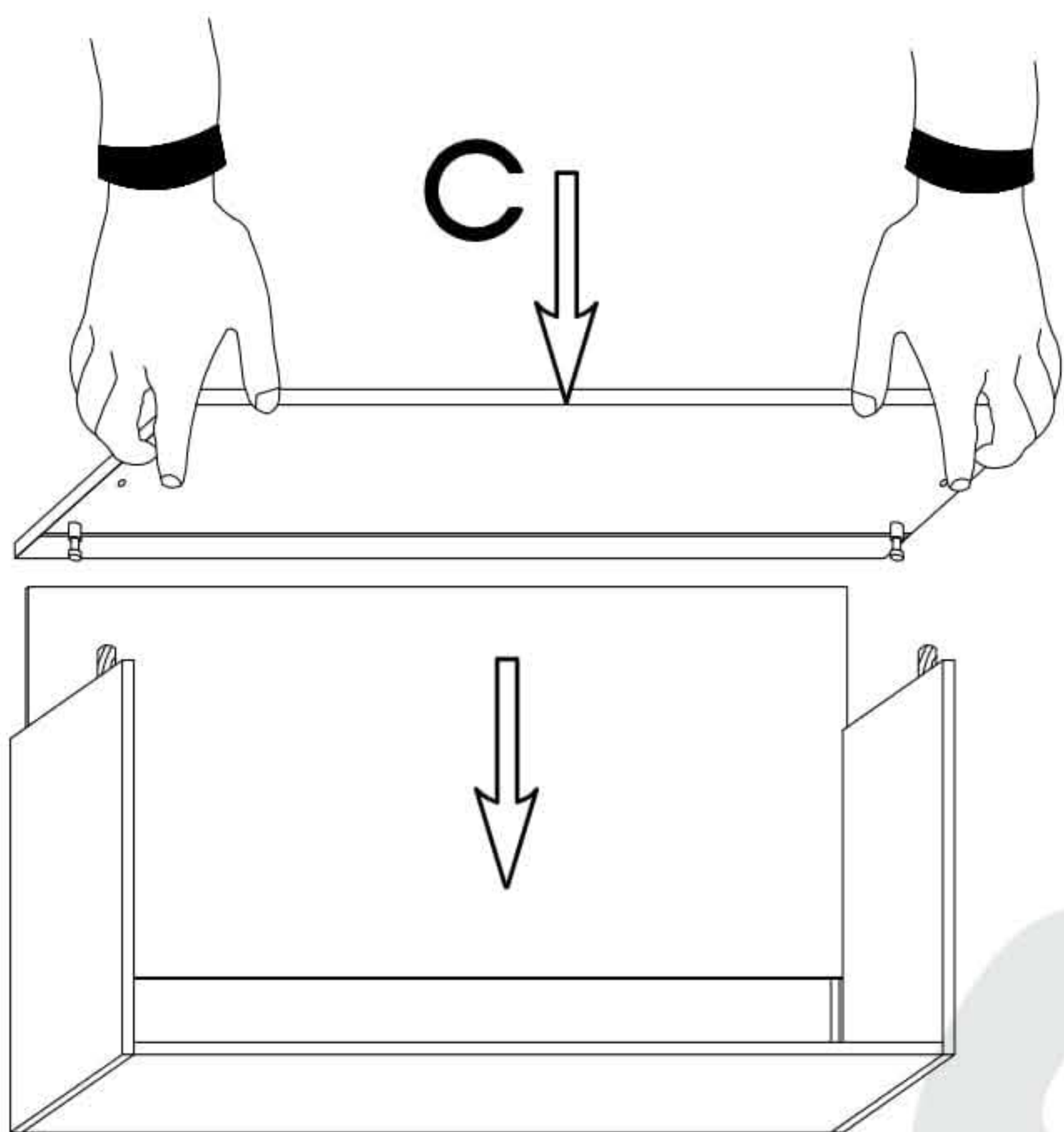
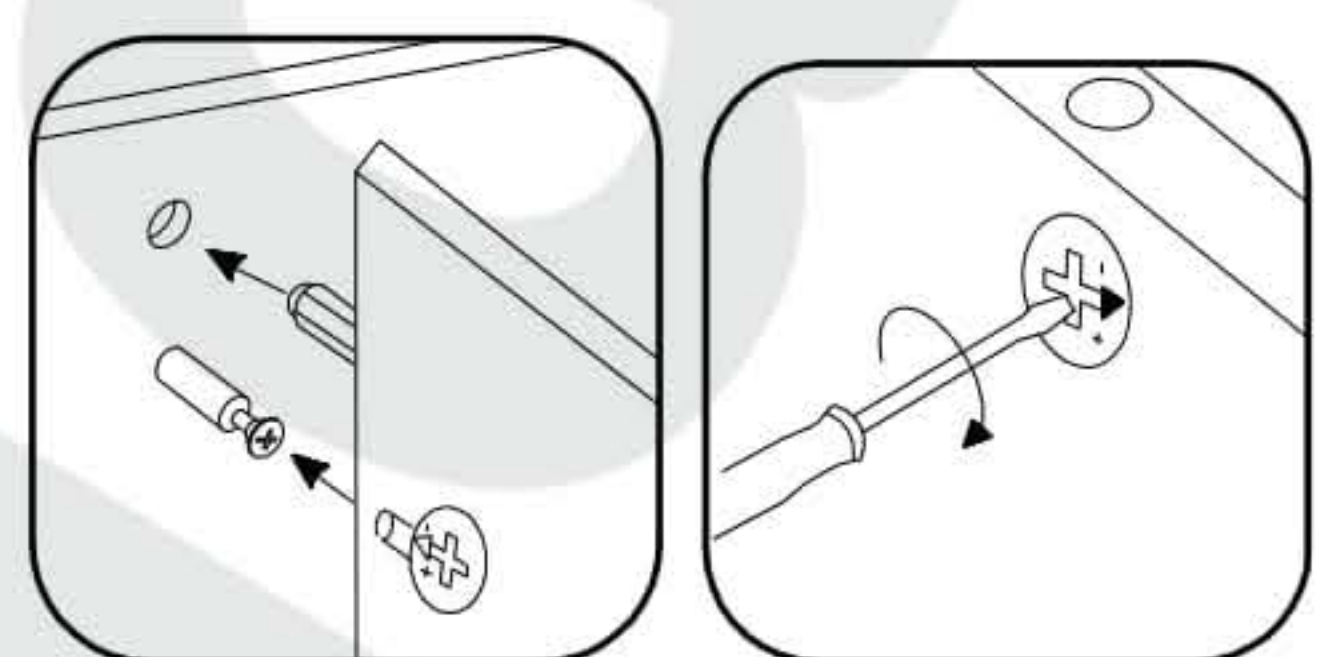
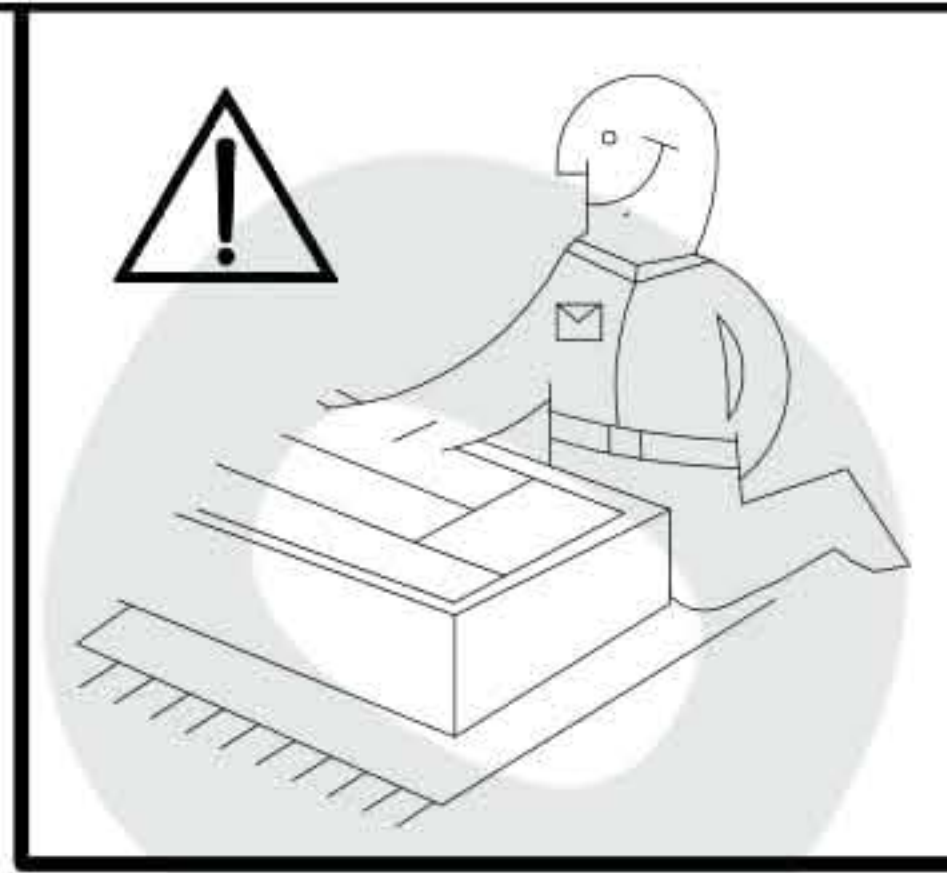
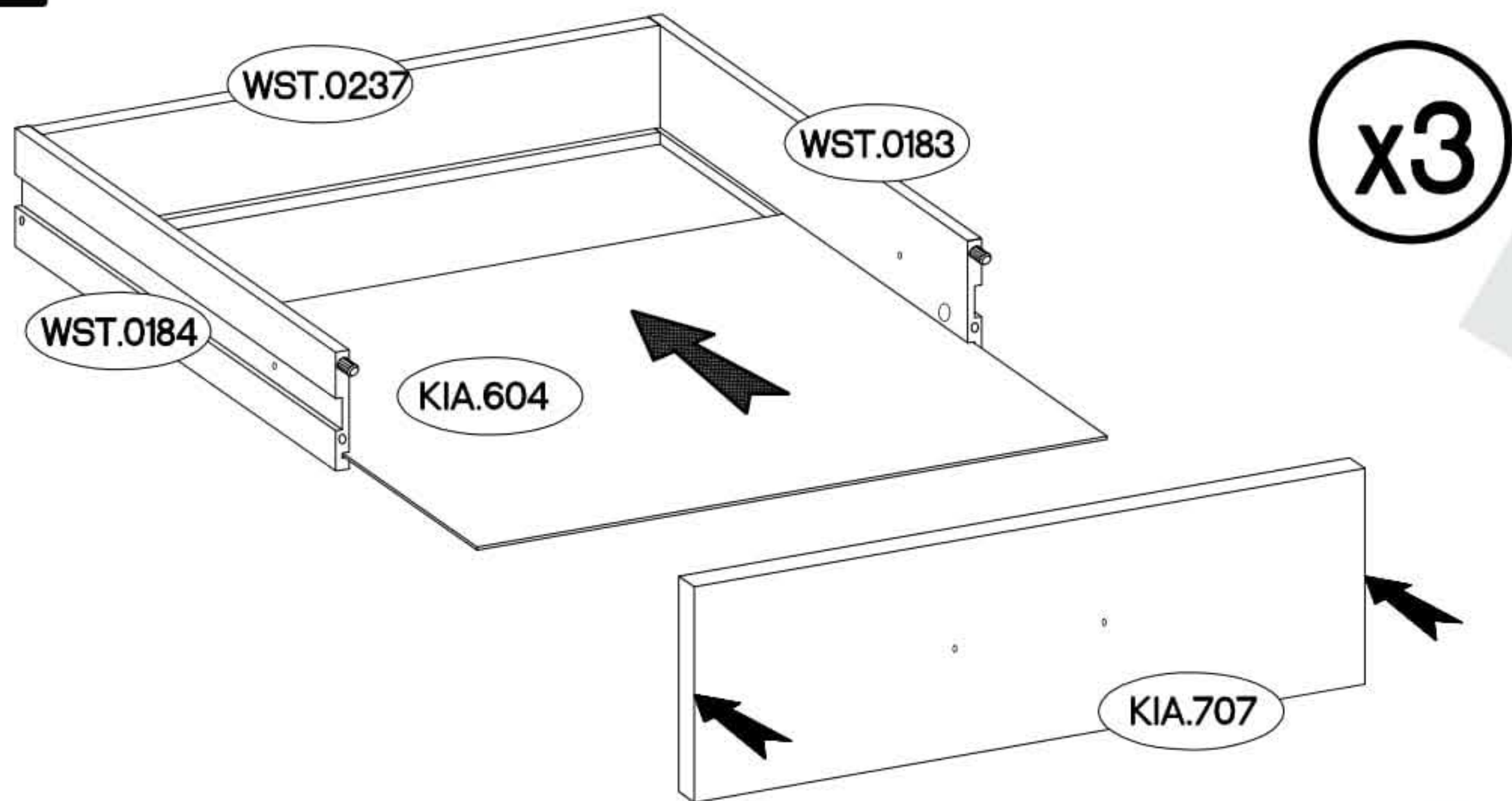

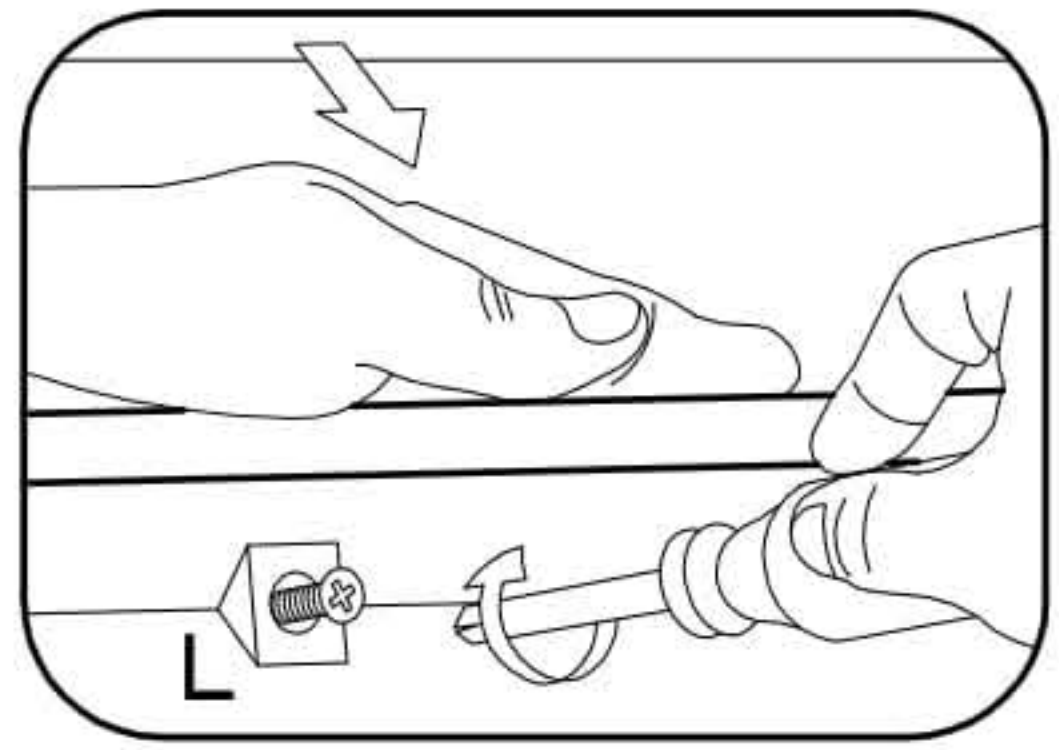
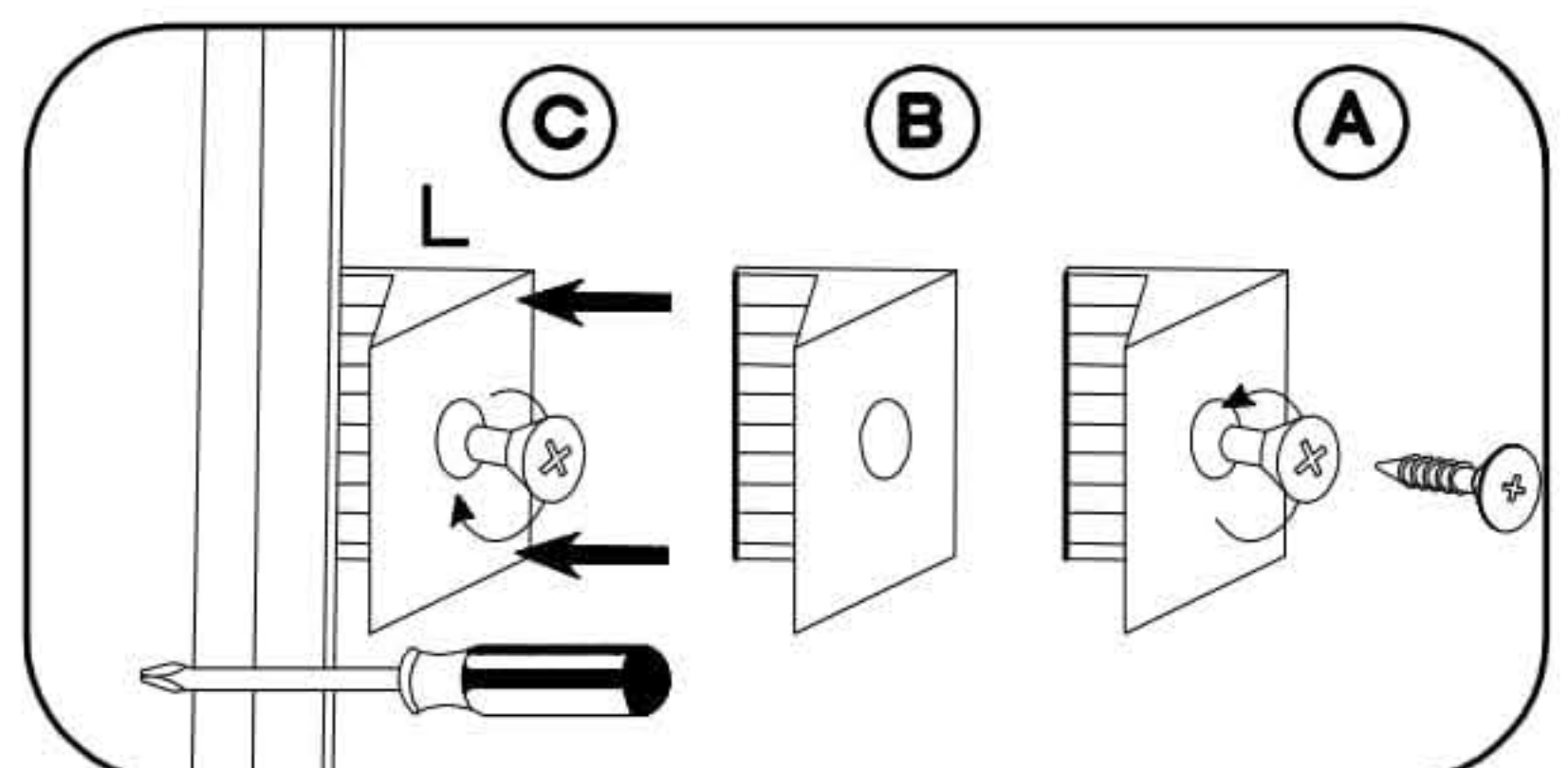
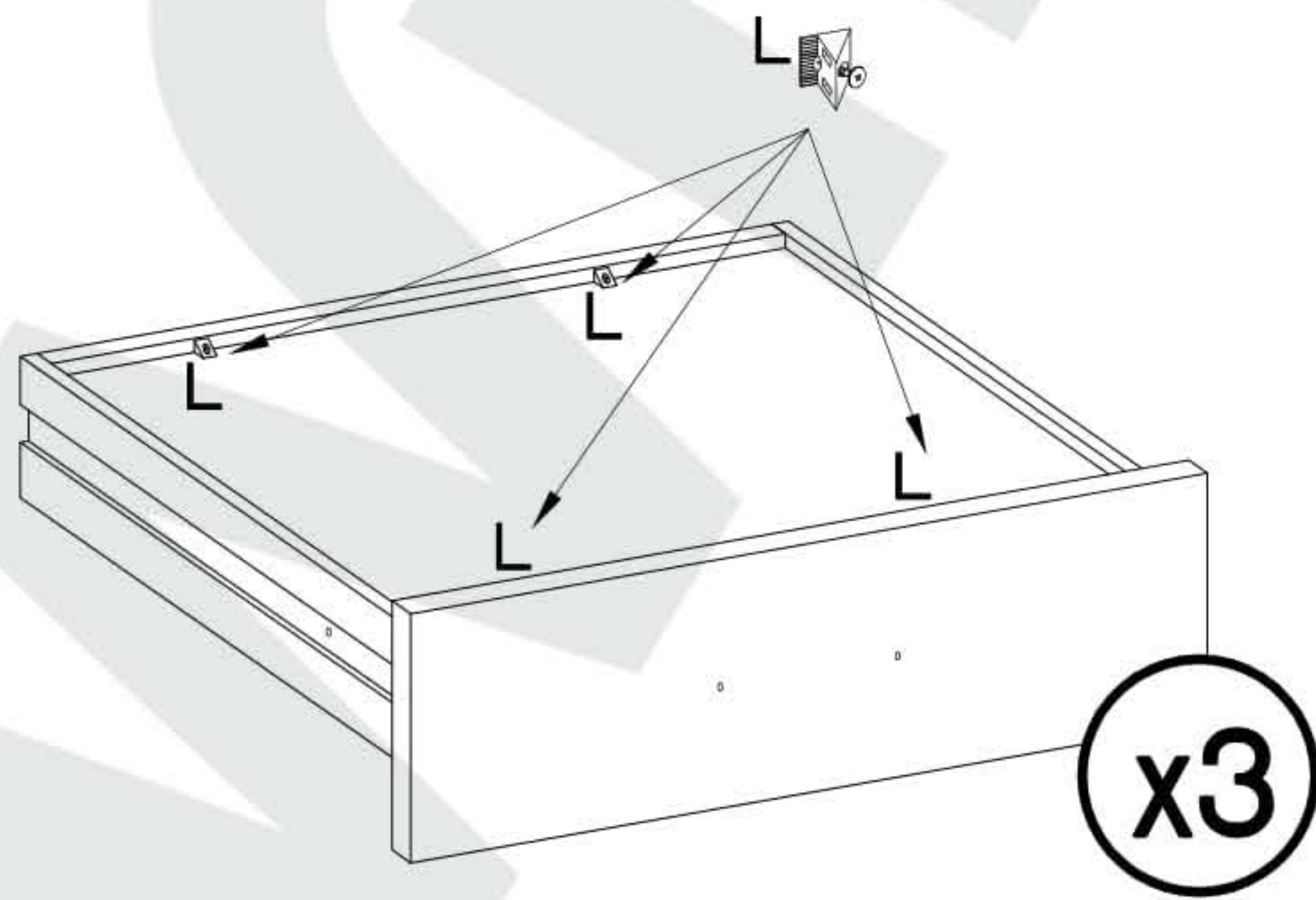
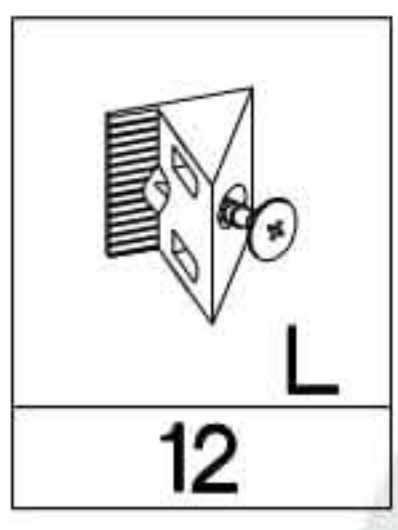

4

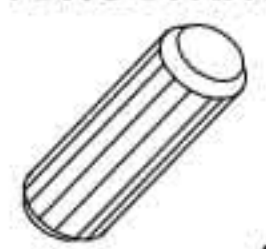
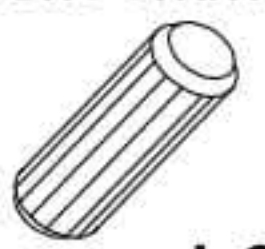





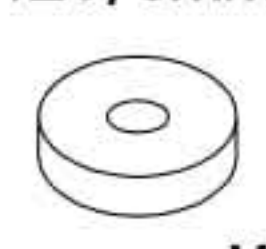

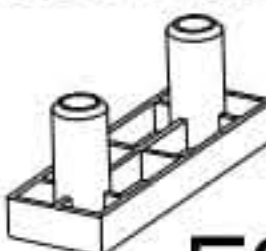
5

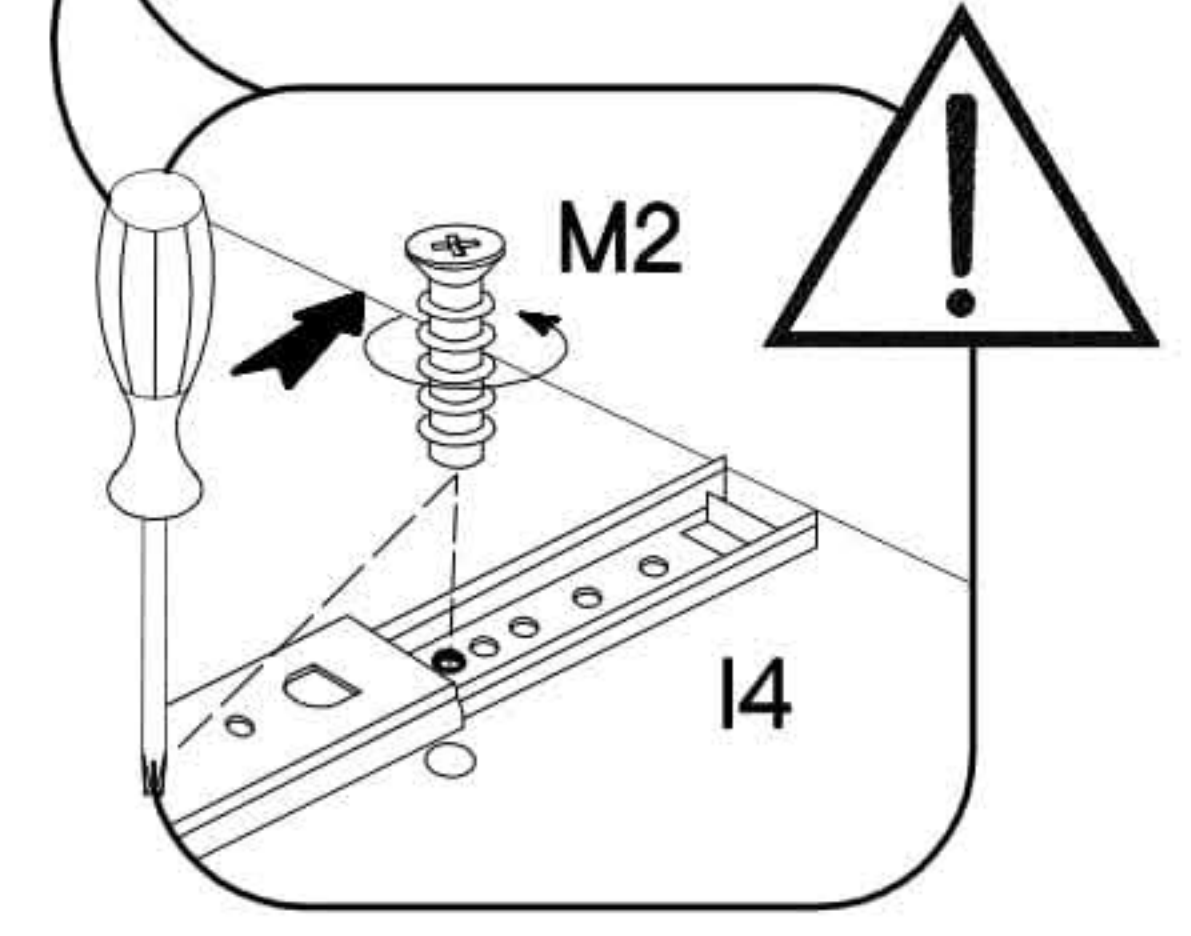
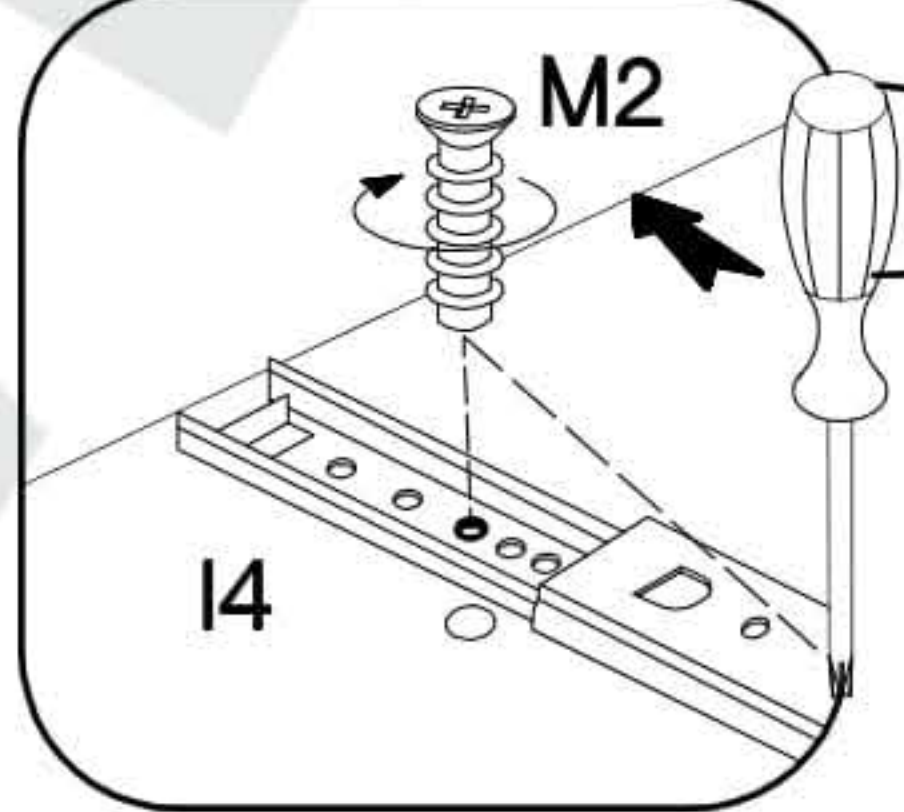
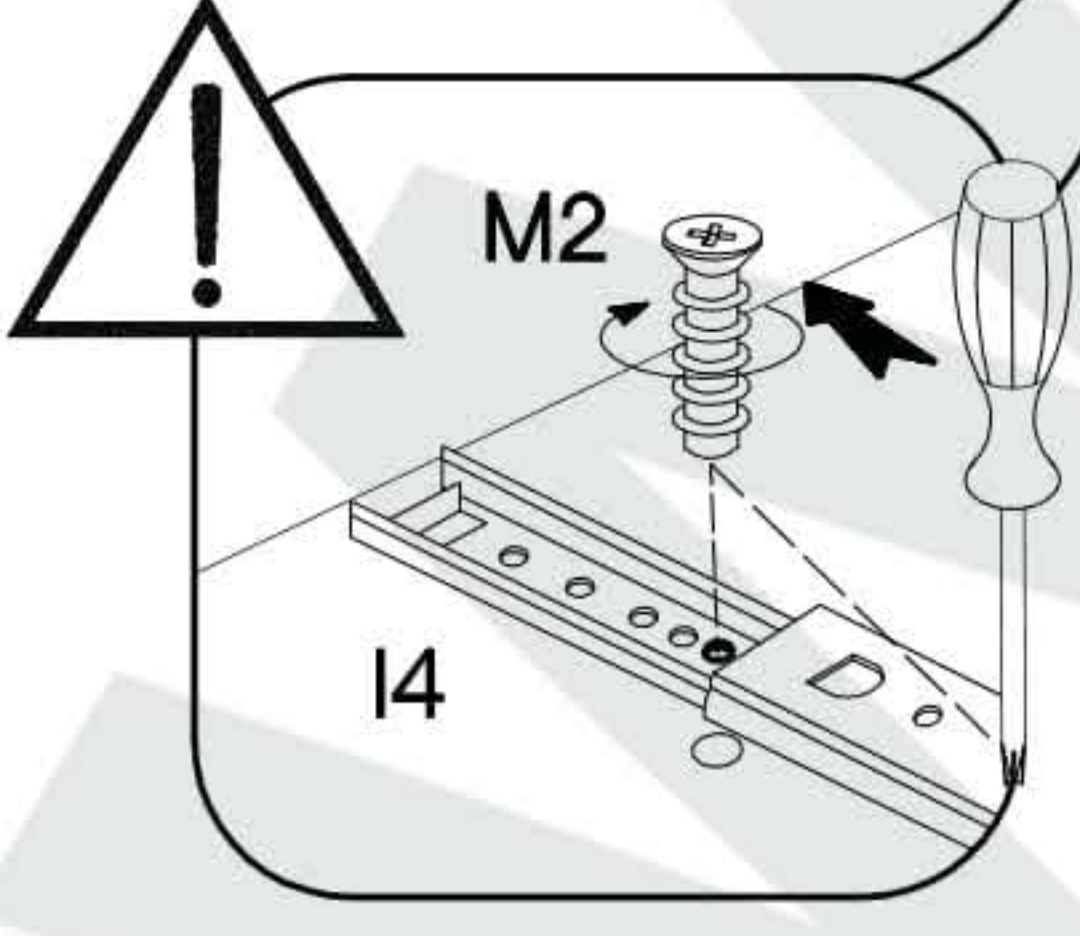
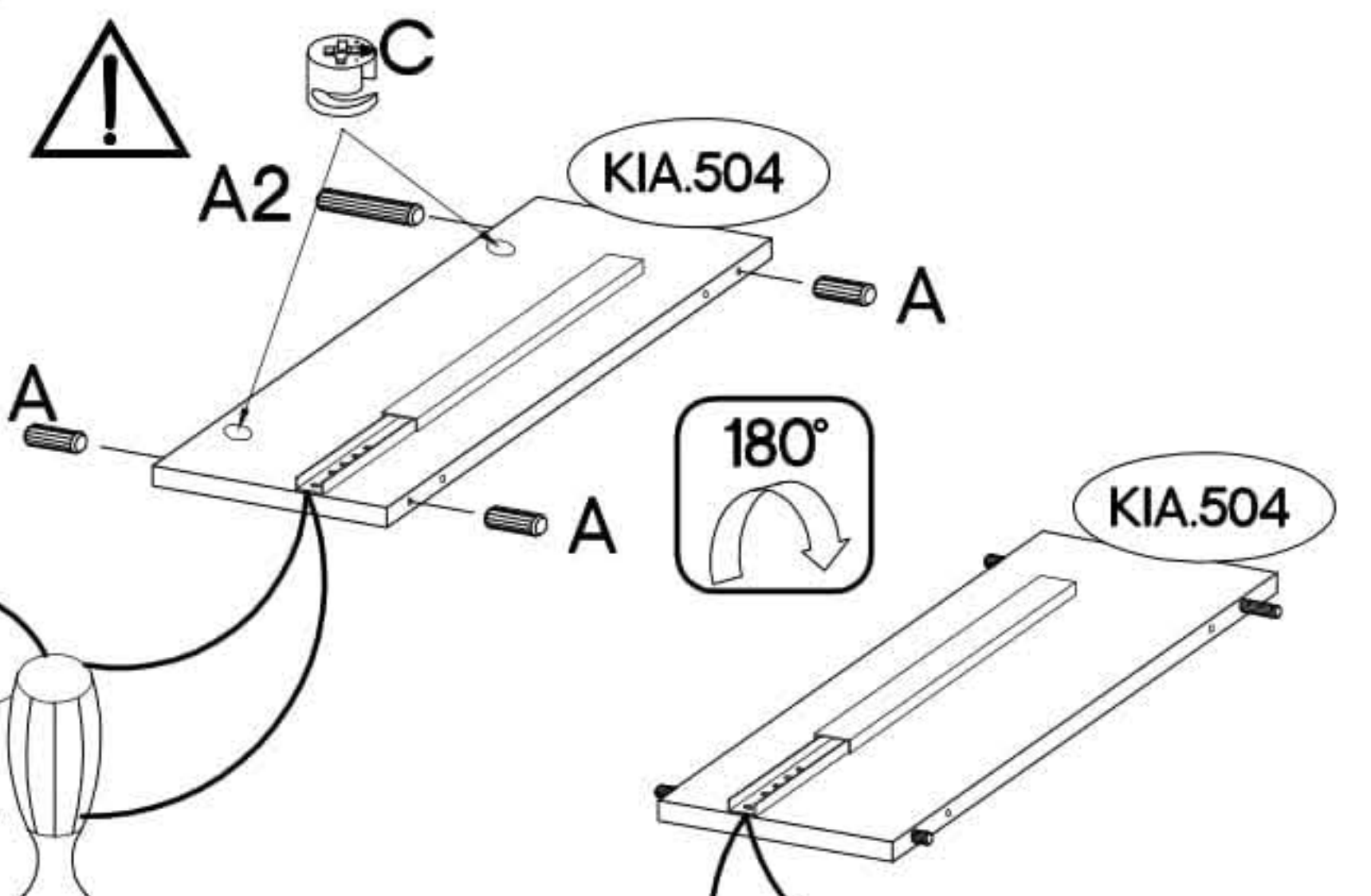
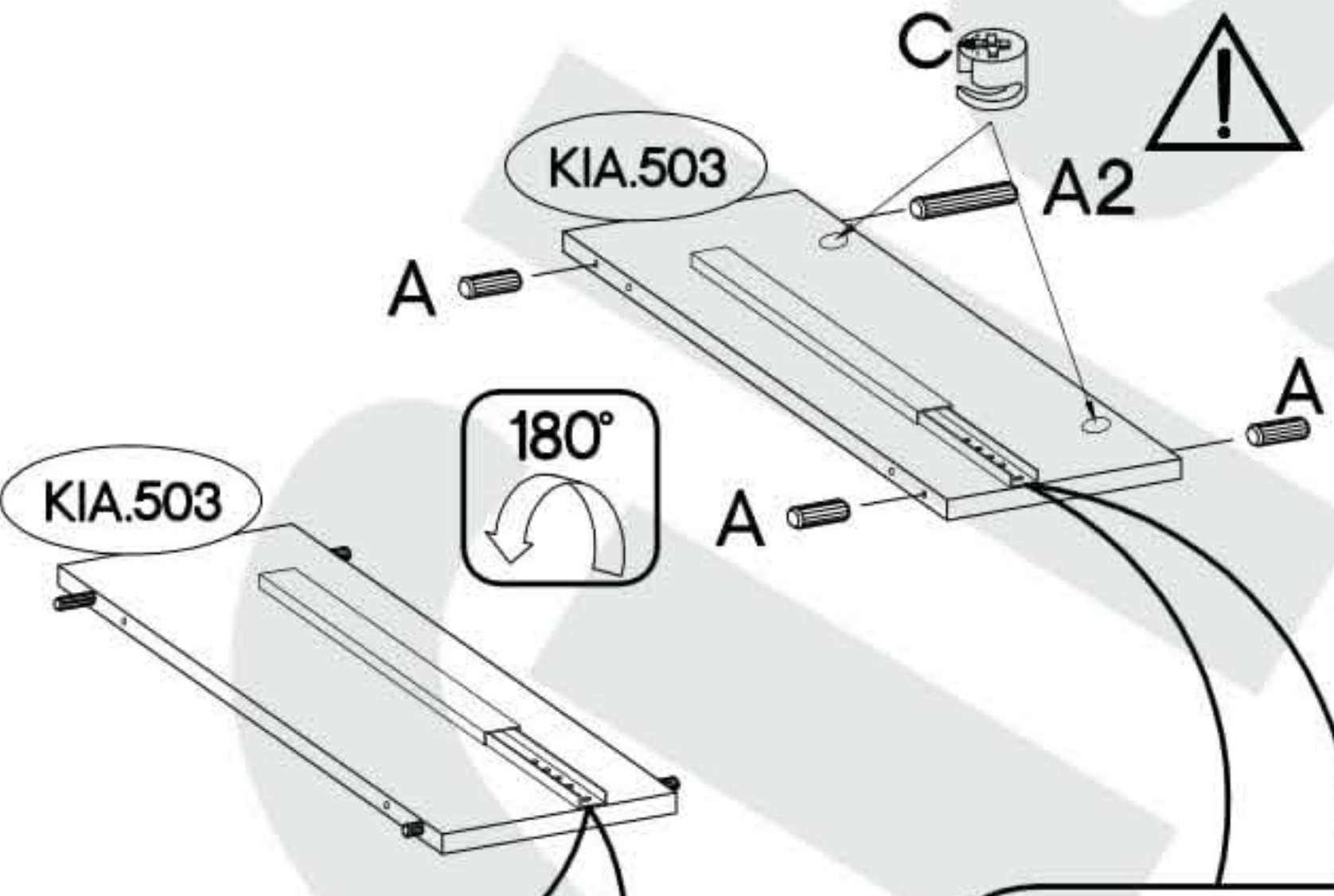
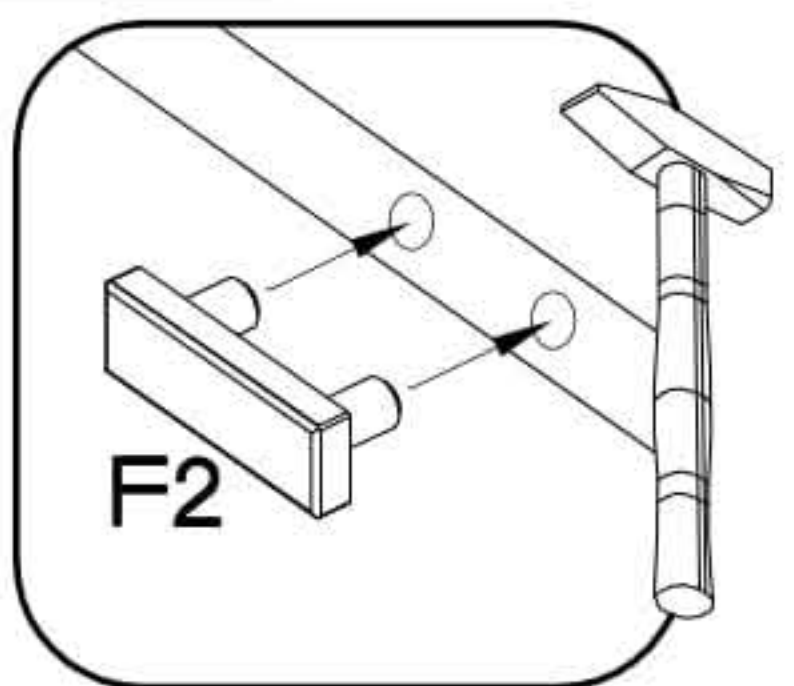
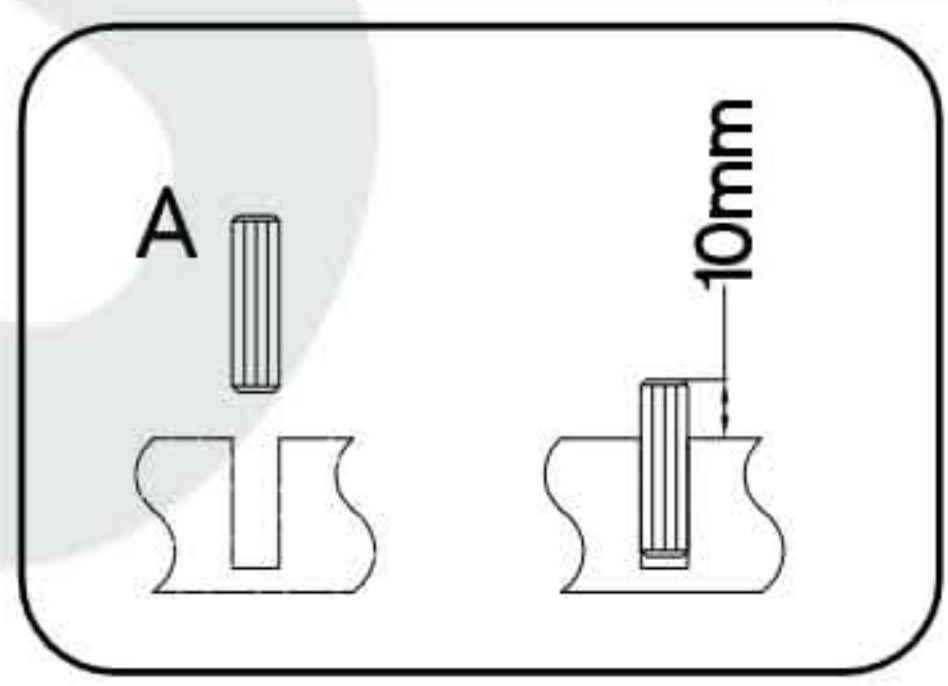
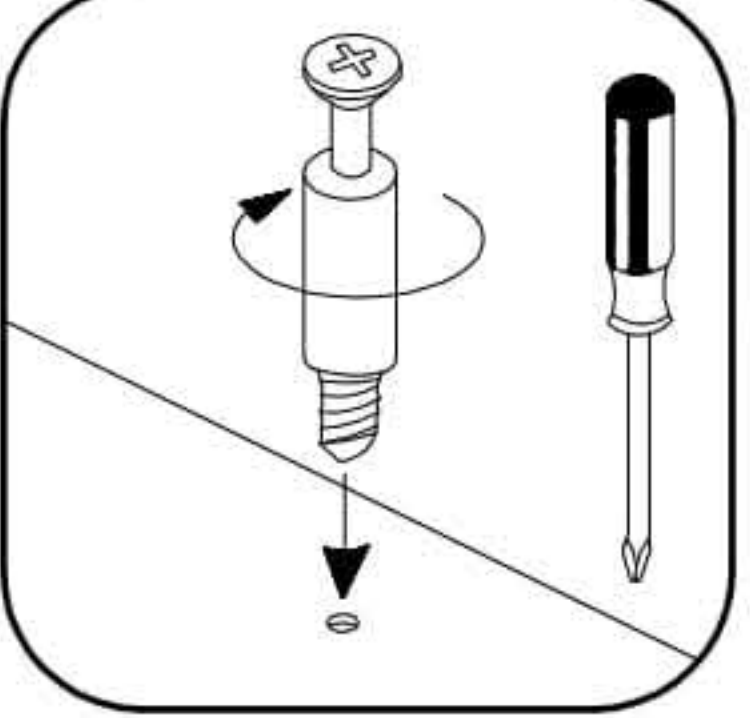
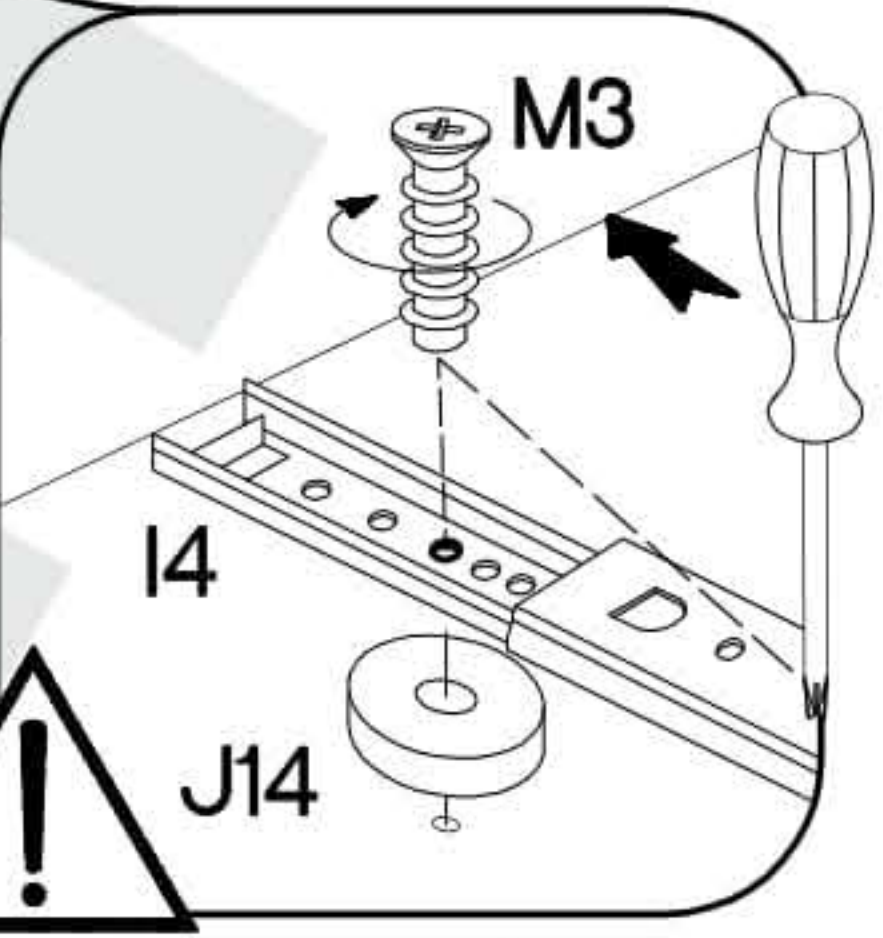
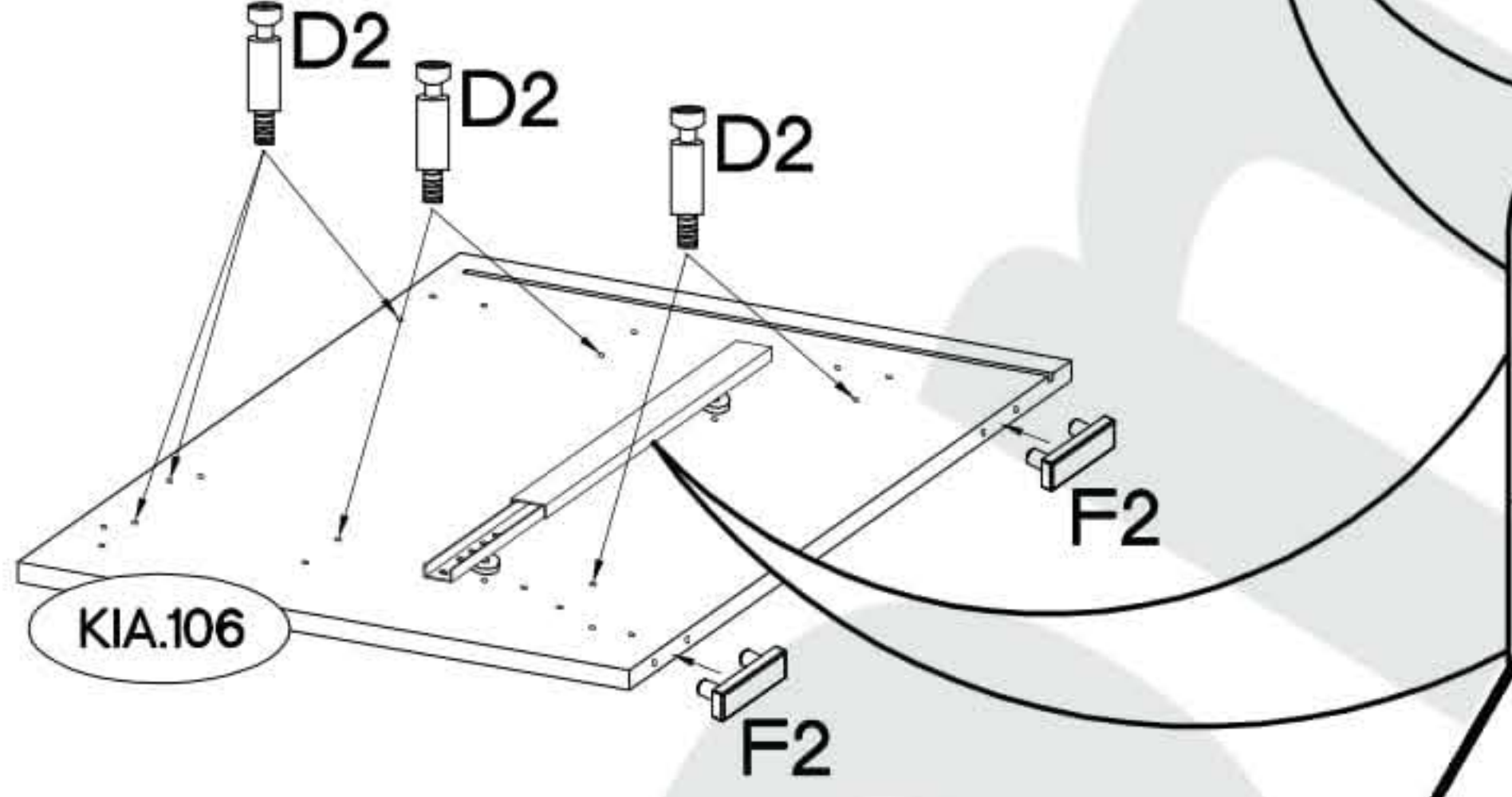
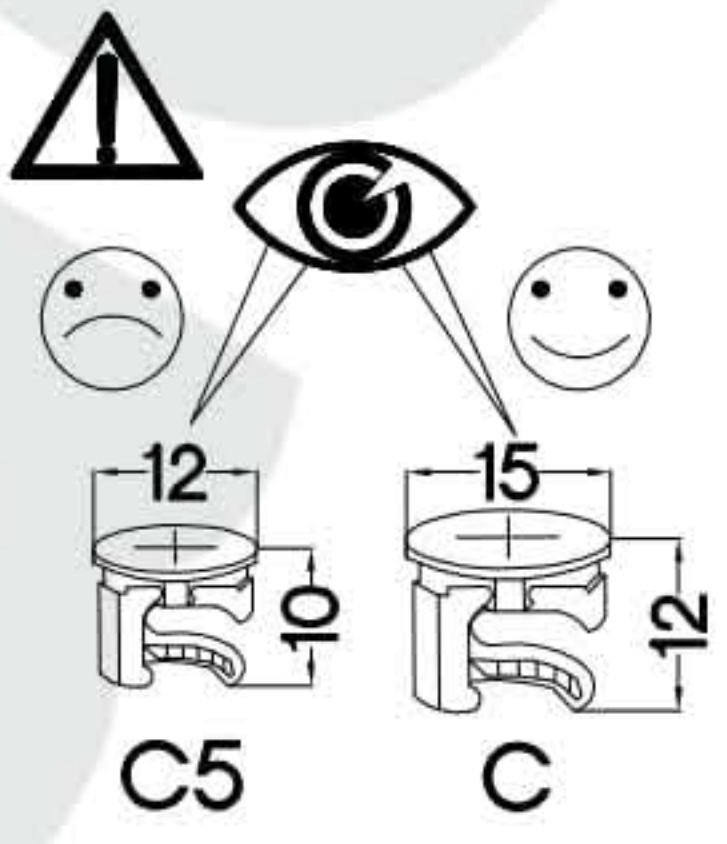
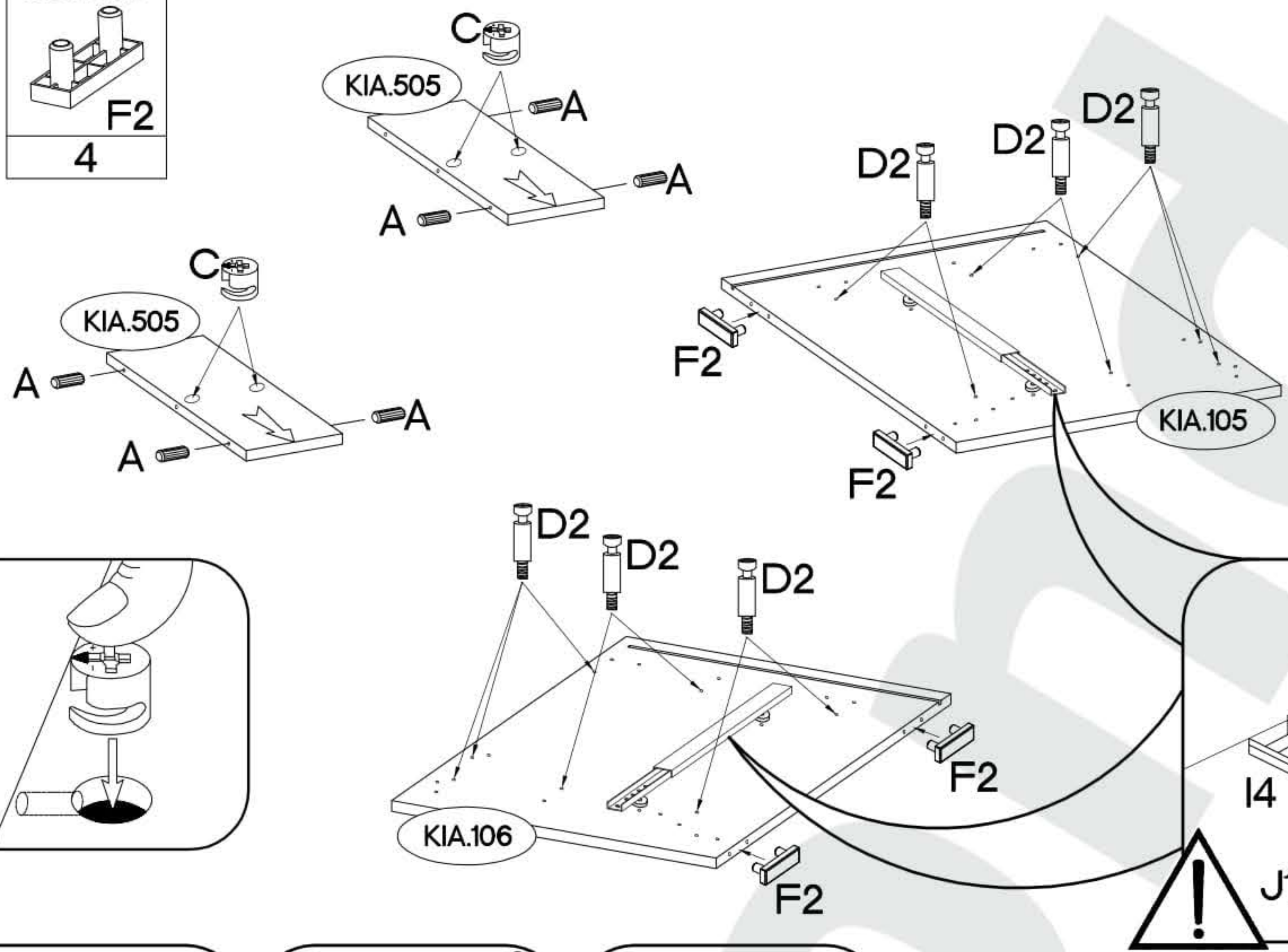
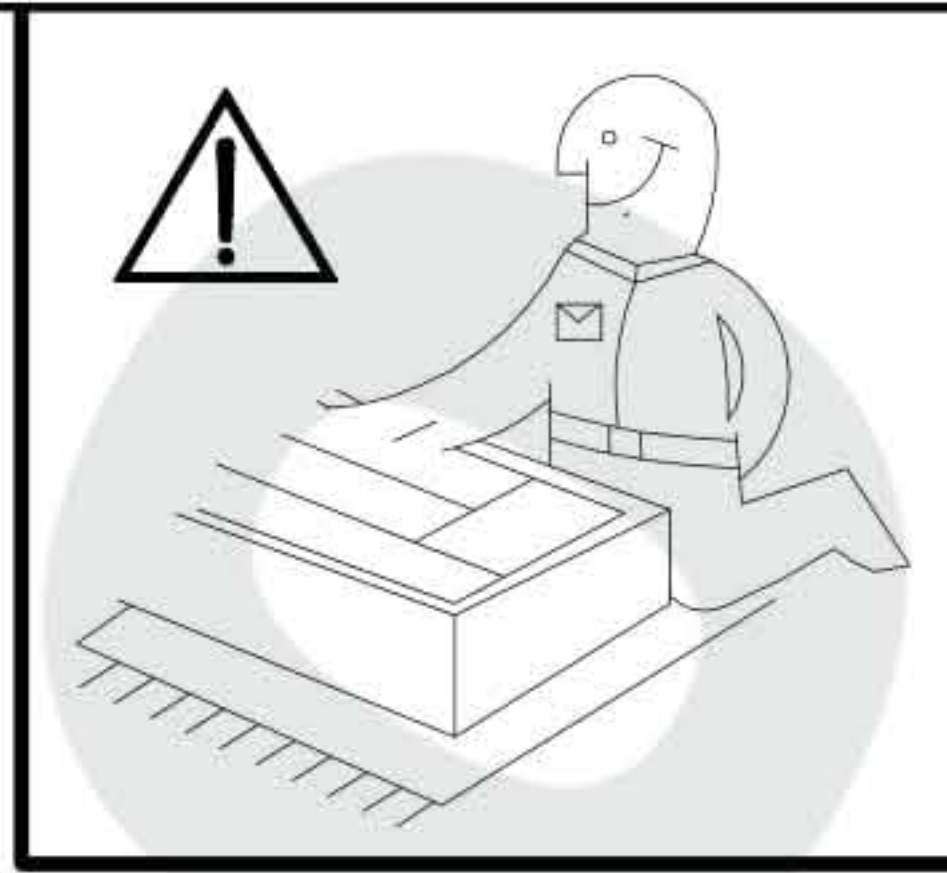

†8x30mm  A	†8x60mm  A2	L=20mm  D2	†15/12mm  C	27/310mm  I4	†6,3x13mm  M2	†6.3x20mm  M3	†20/8mm  J14
12	2	14	8	3	8	4	4

6.5x48x16  F2
4

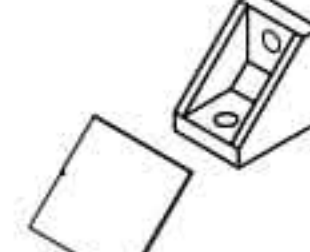

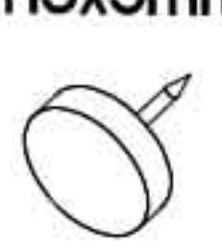
 †8x30mm A	 L=20mm D2	 †15/12mm C	 T3	 †4.0x16mm P1	 †15x5mm F4
18	8	14	1	1	2

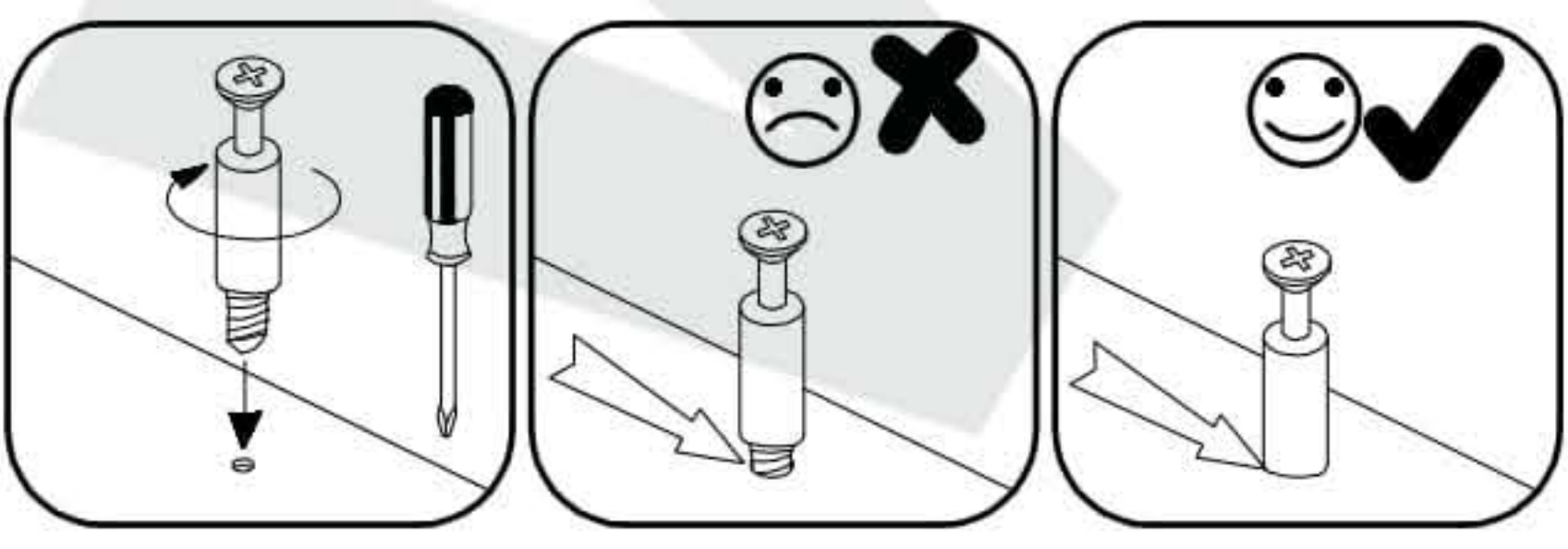
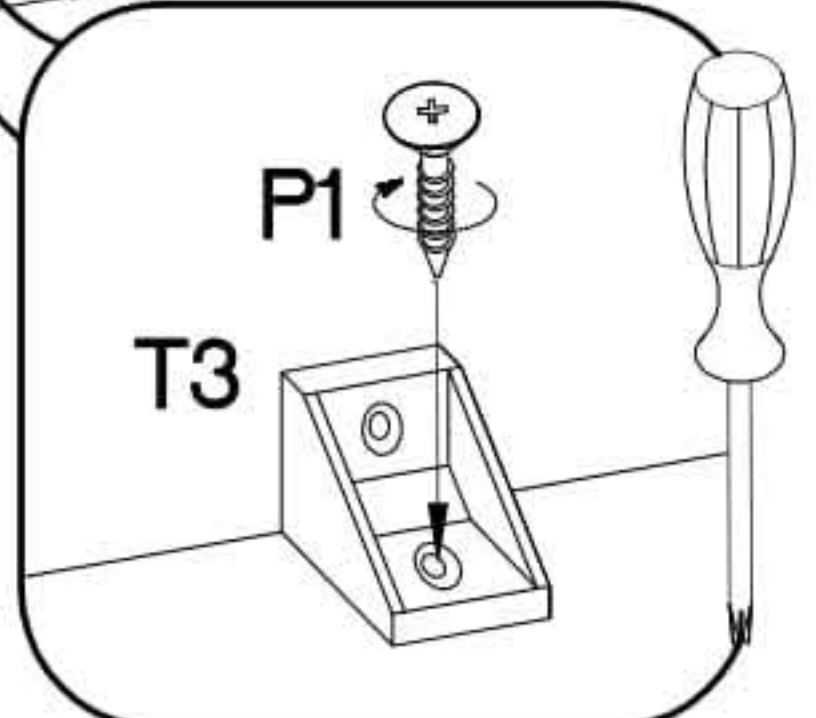
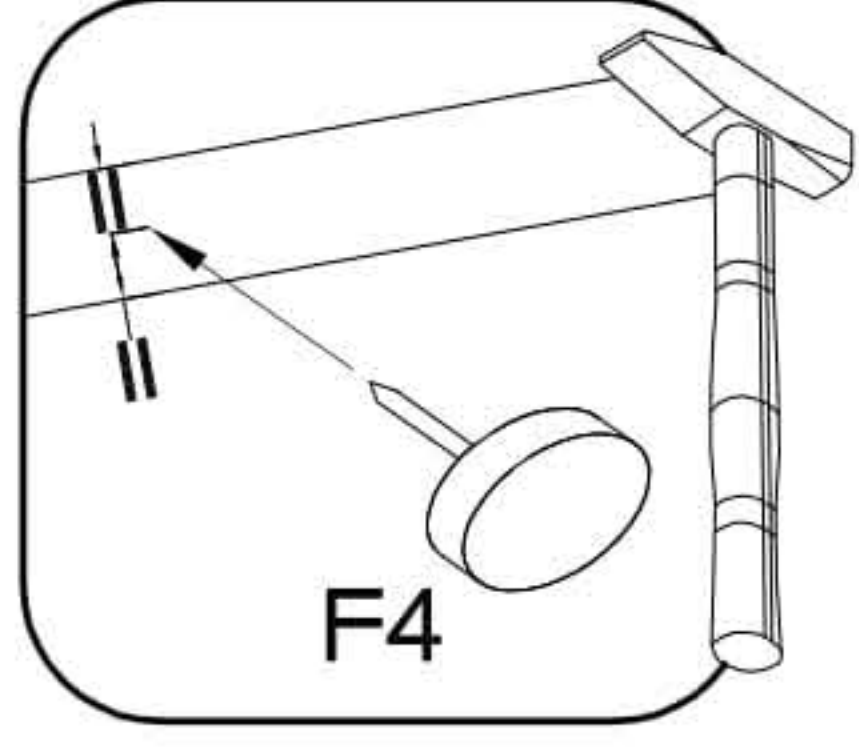
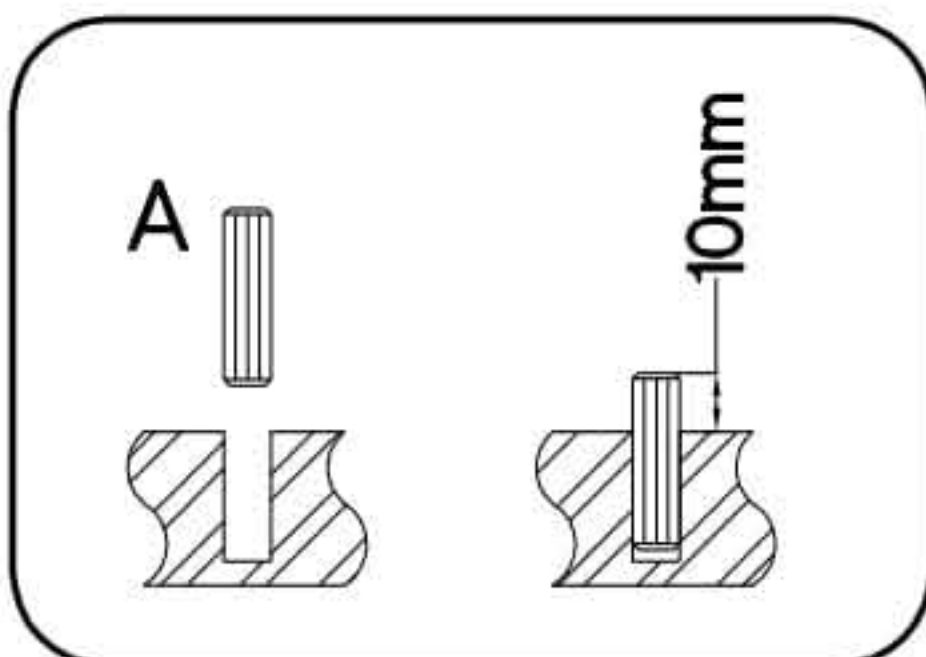
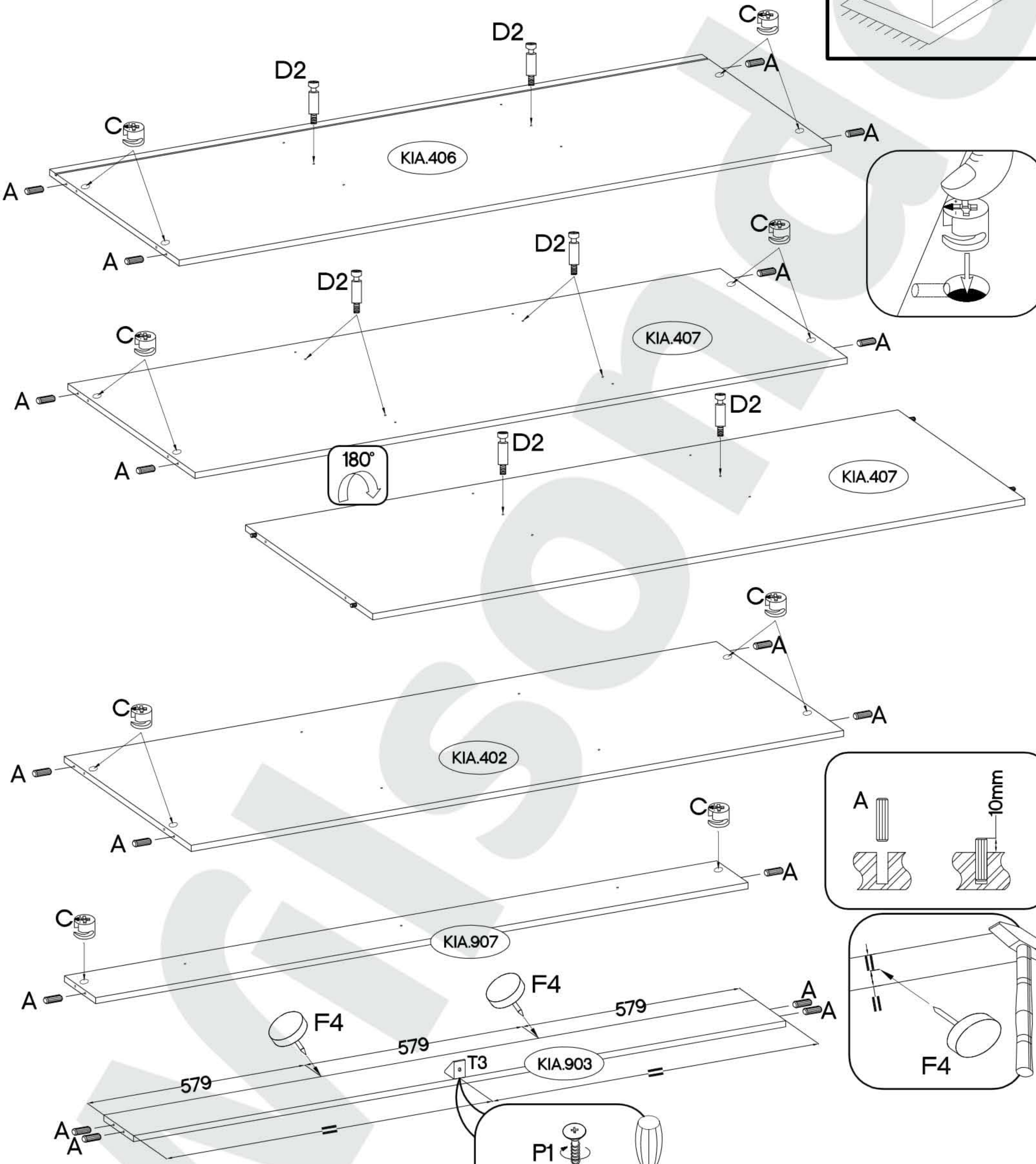
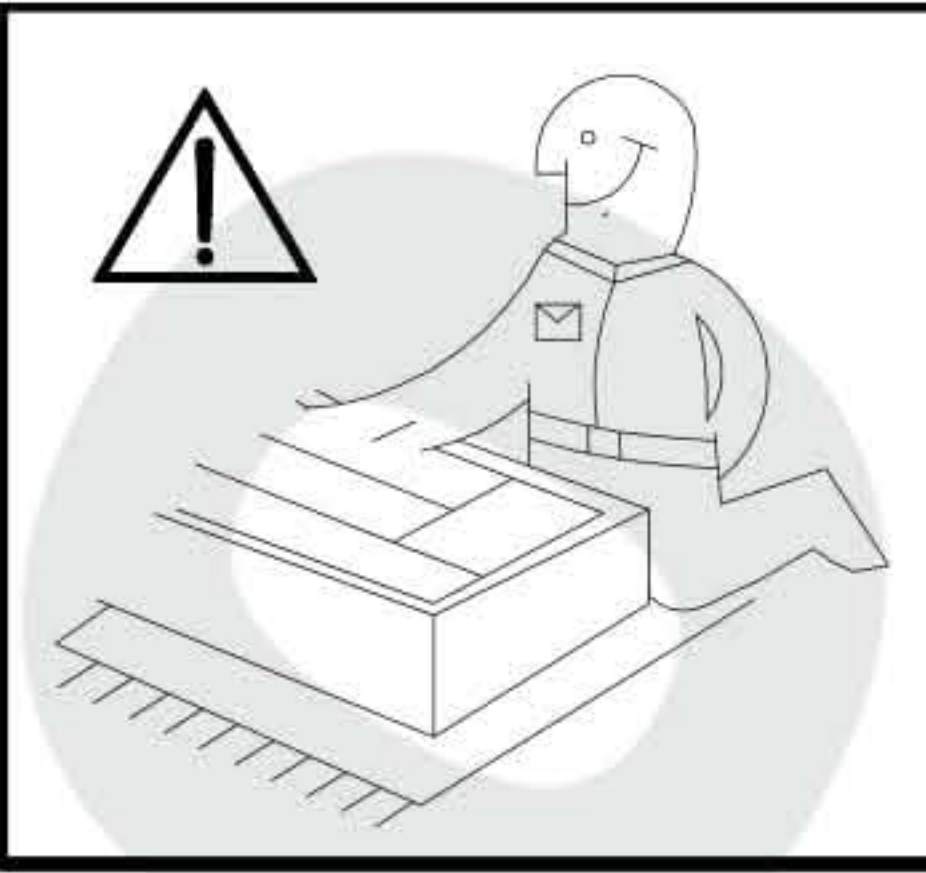

8

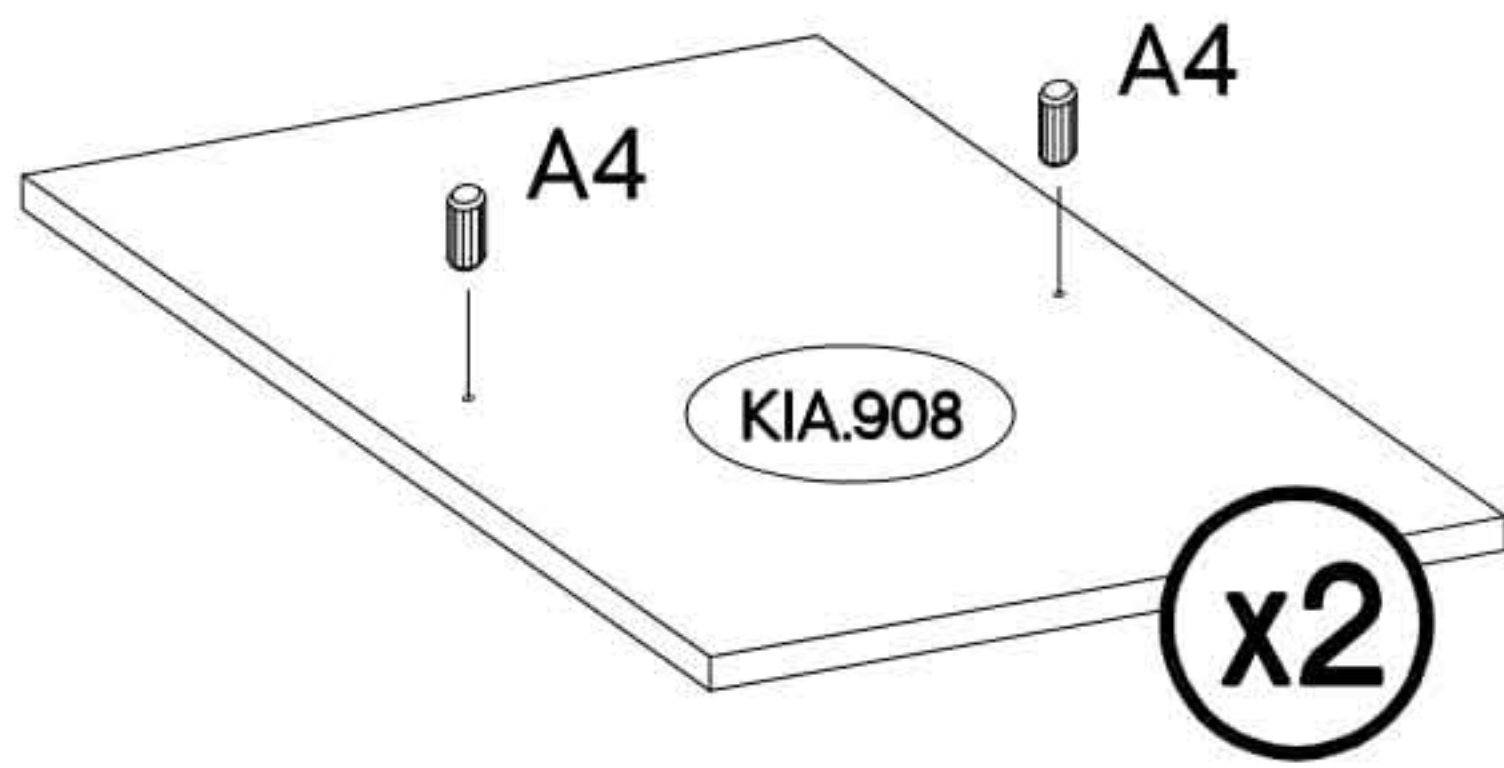
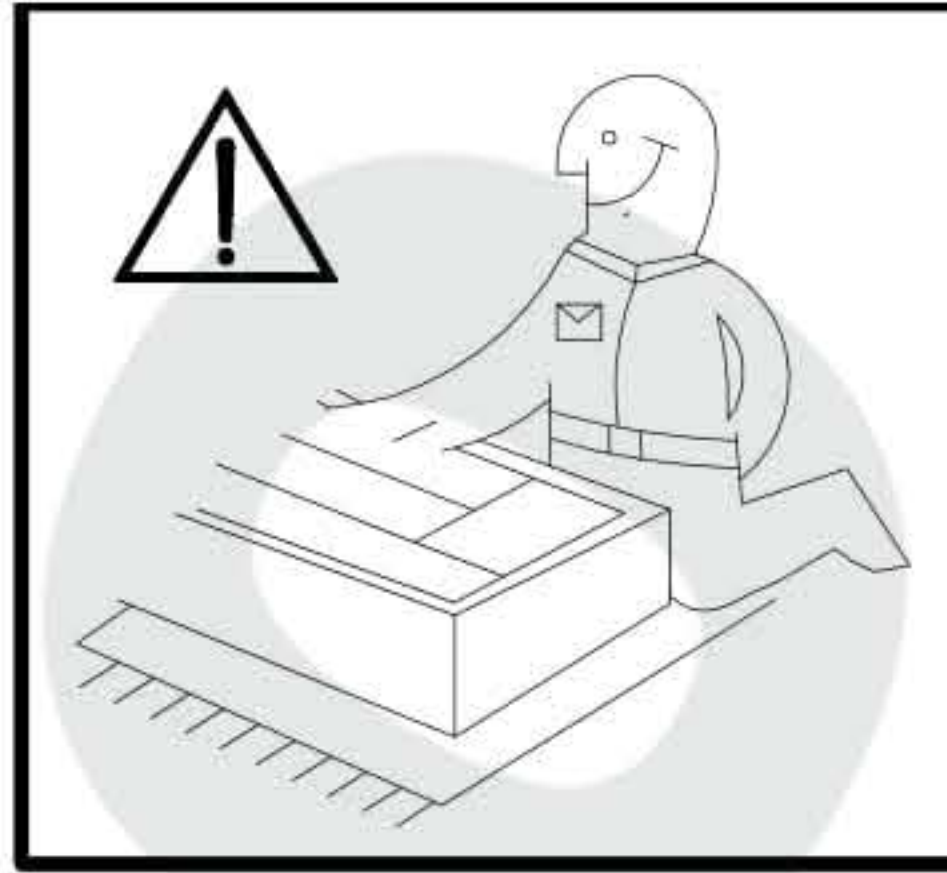
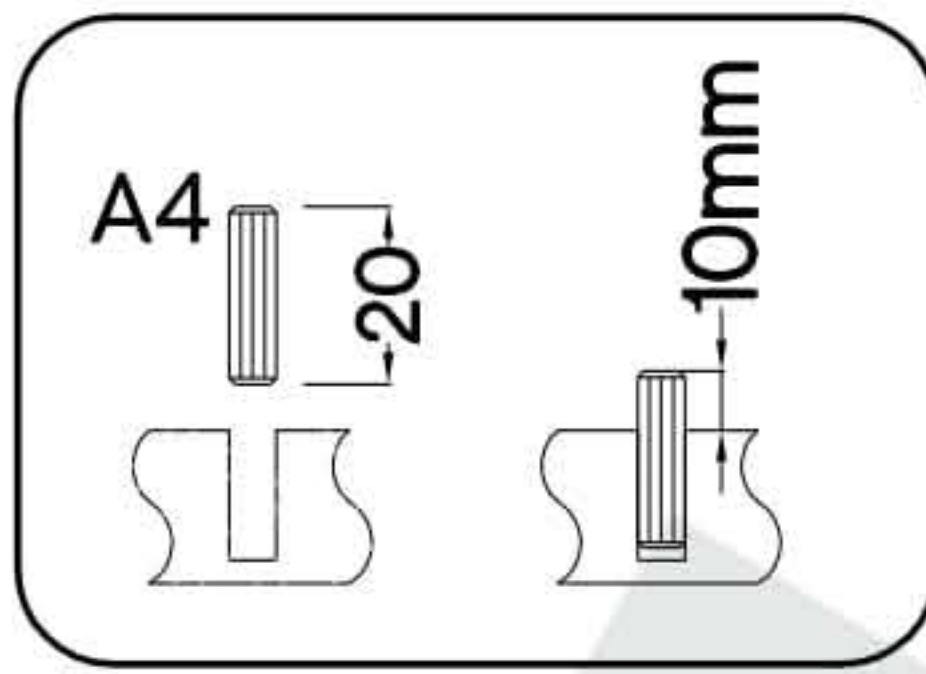

9

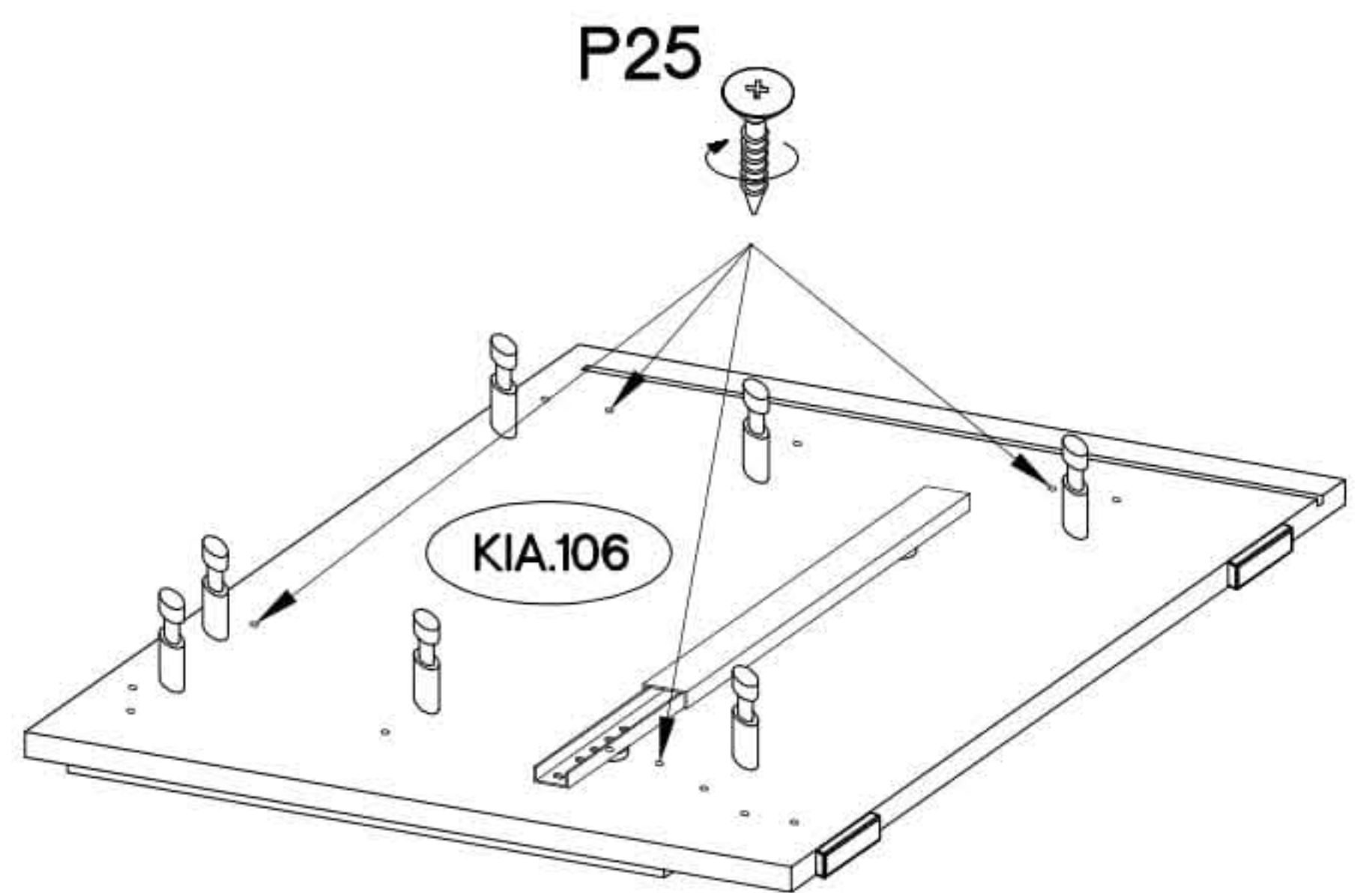
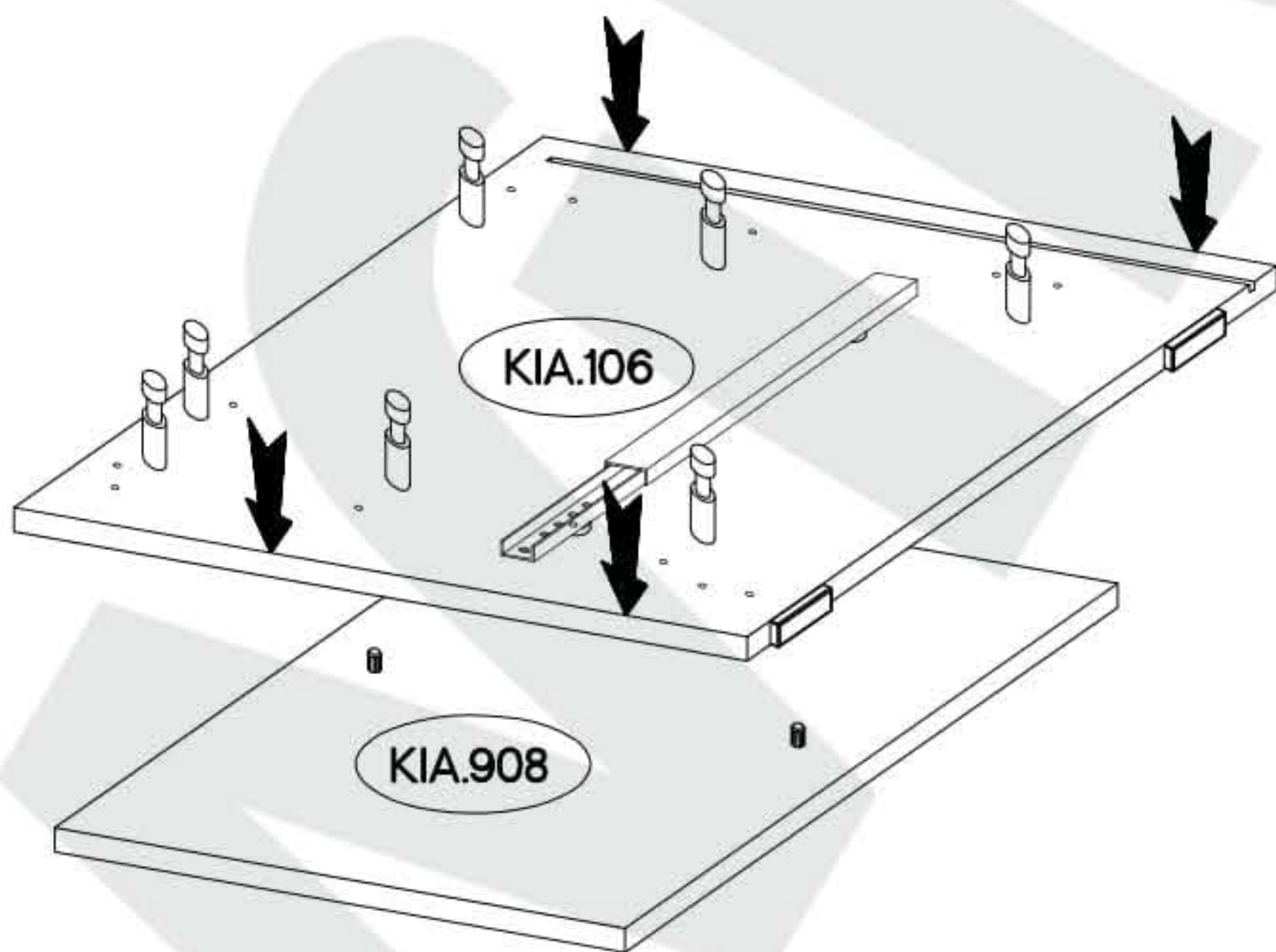
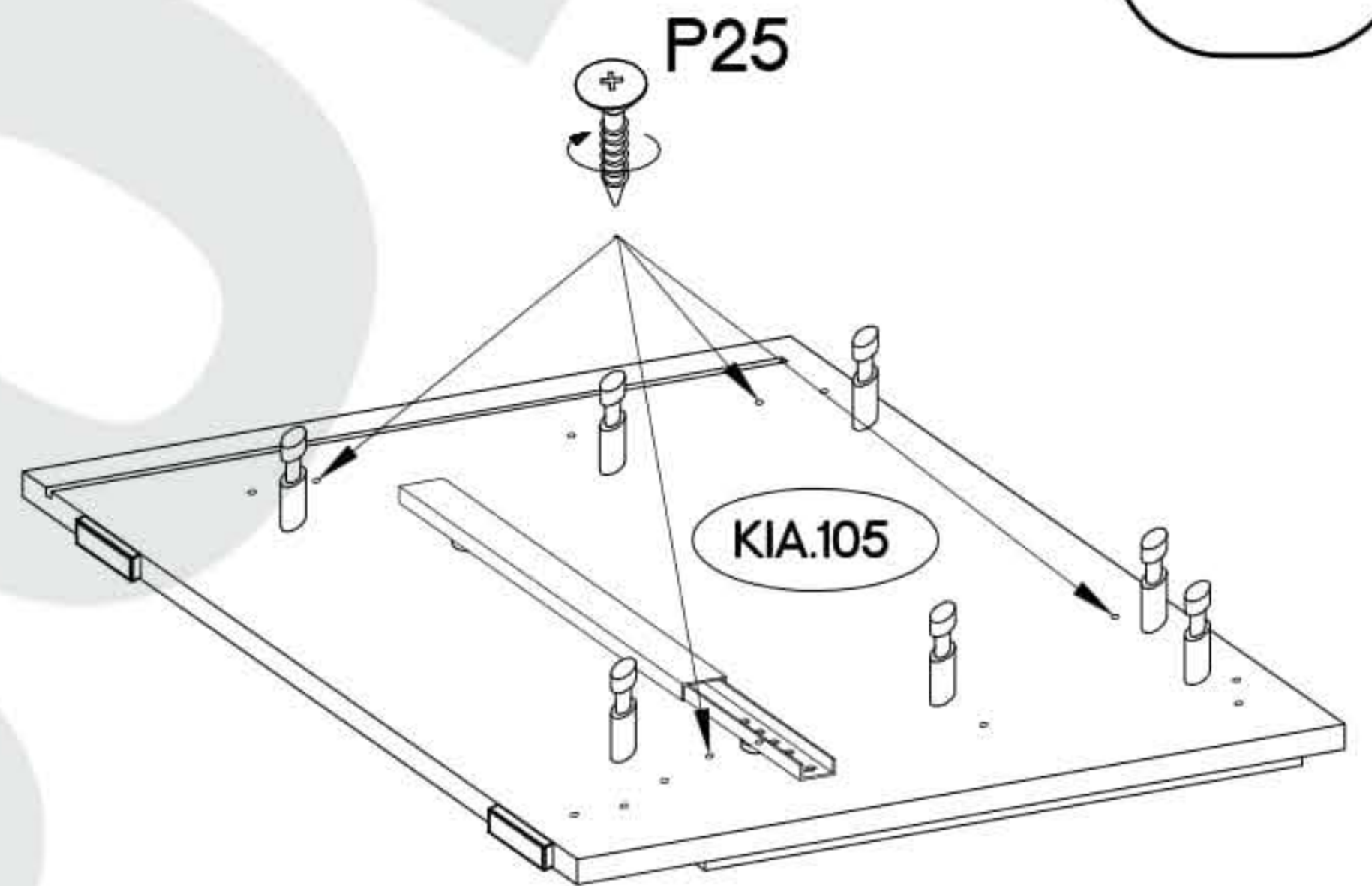
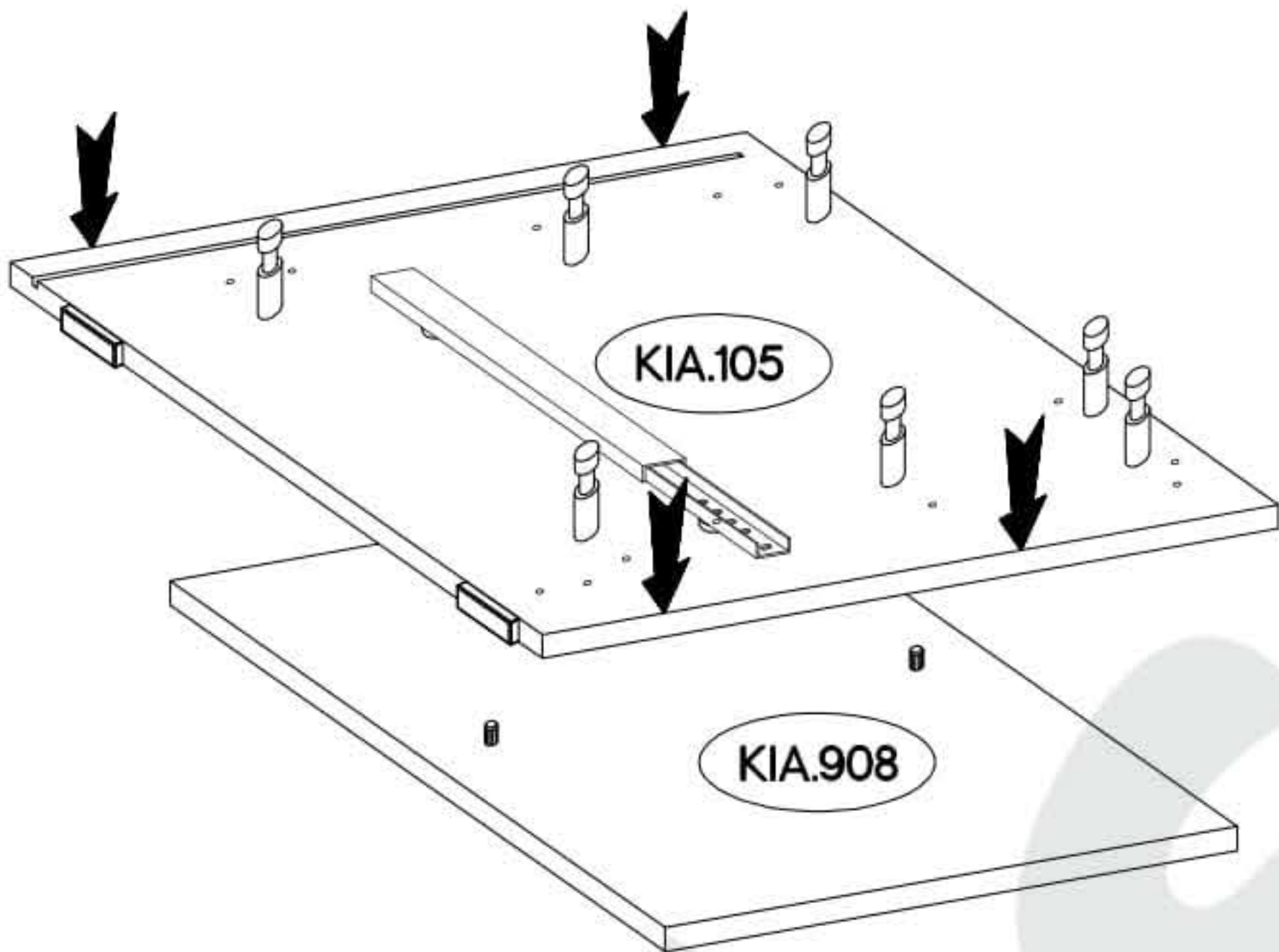
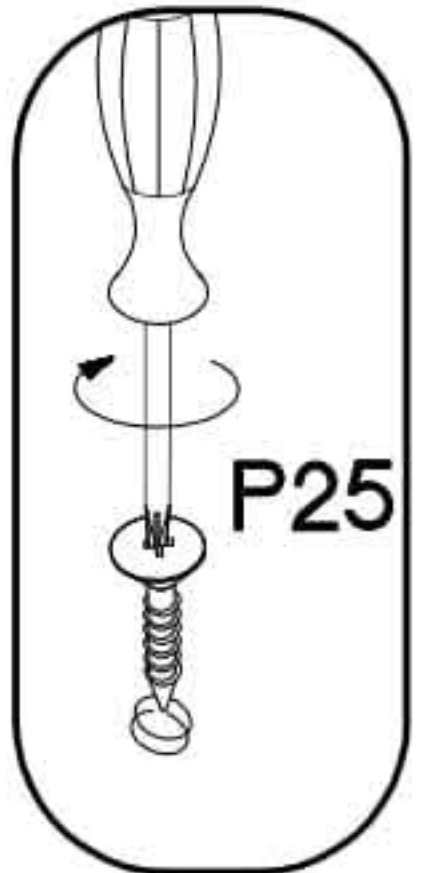
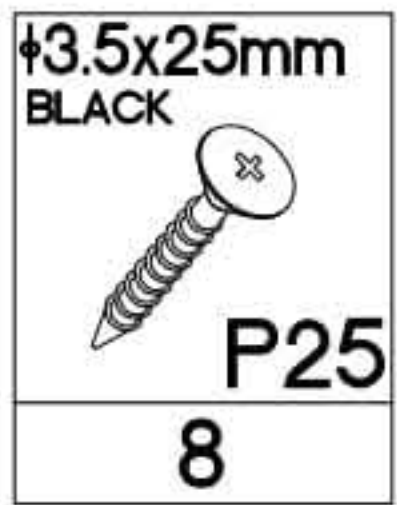

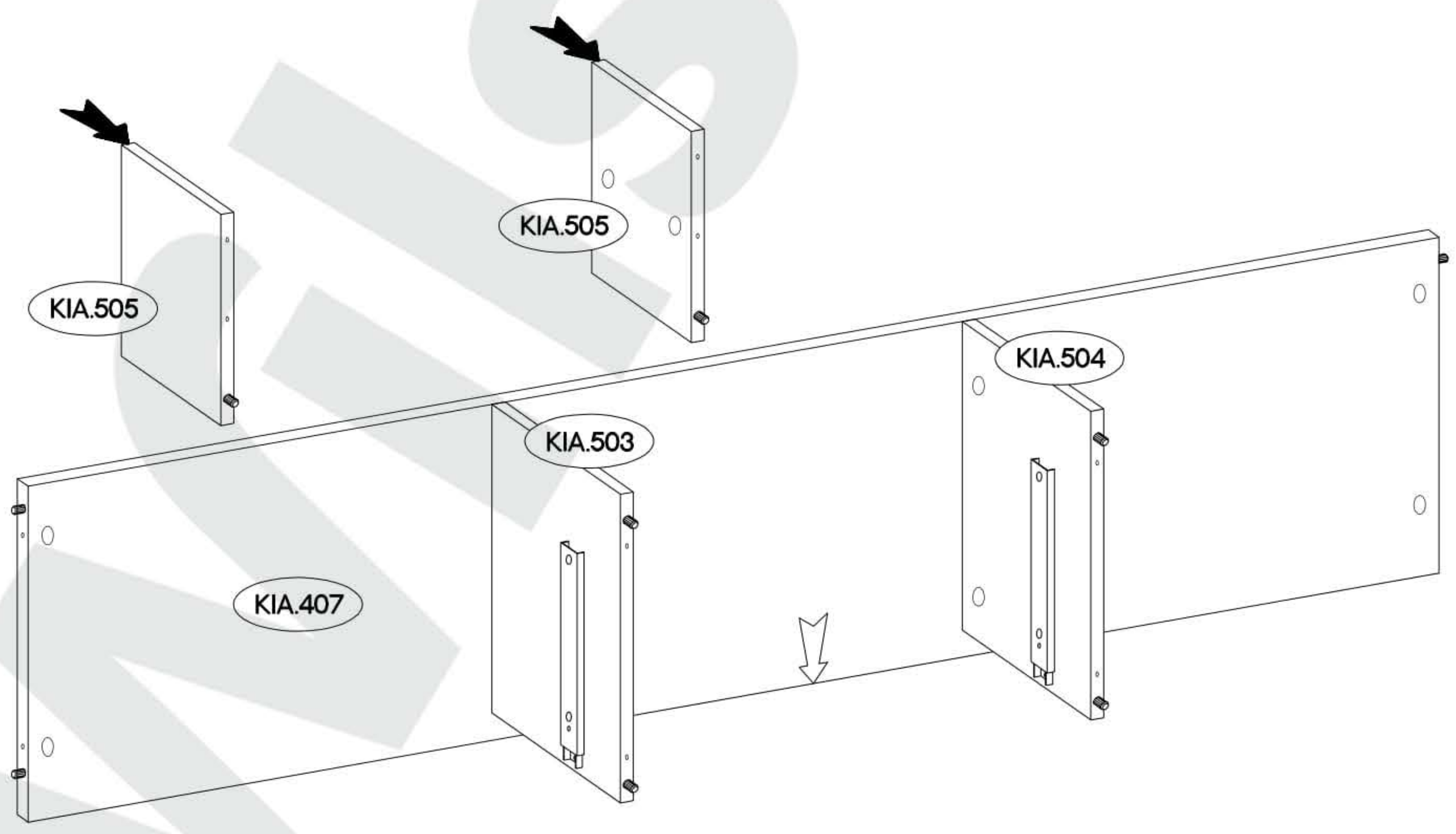
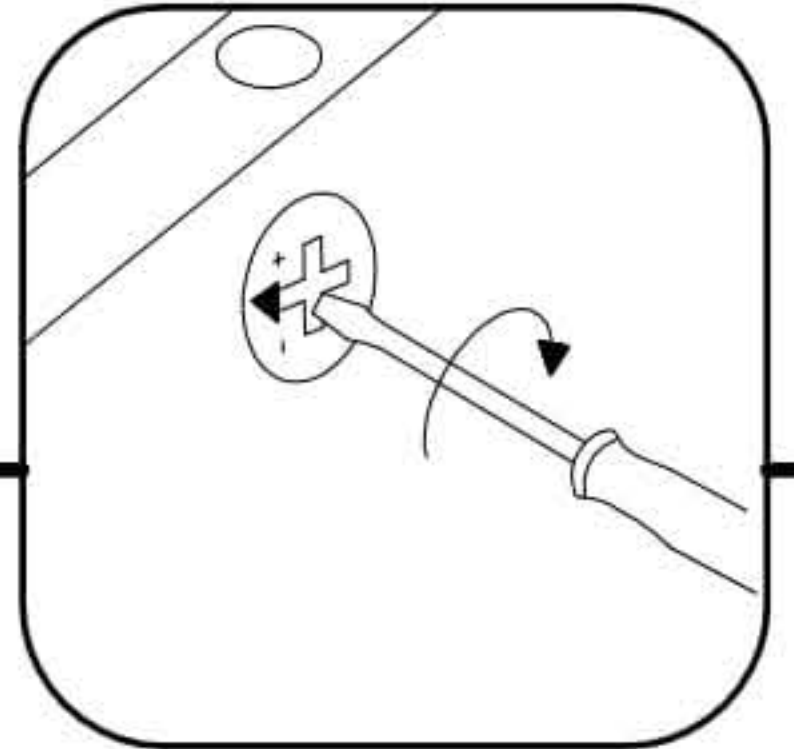
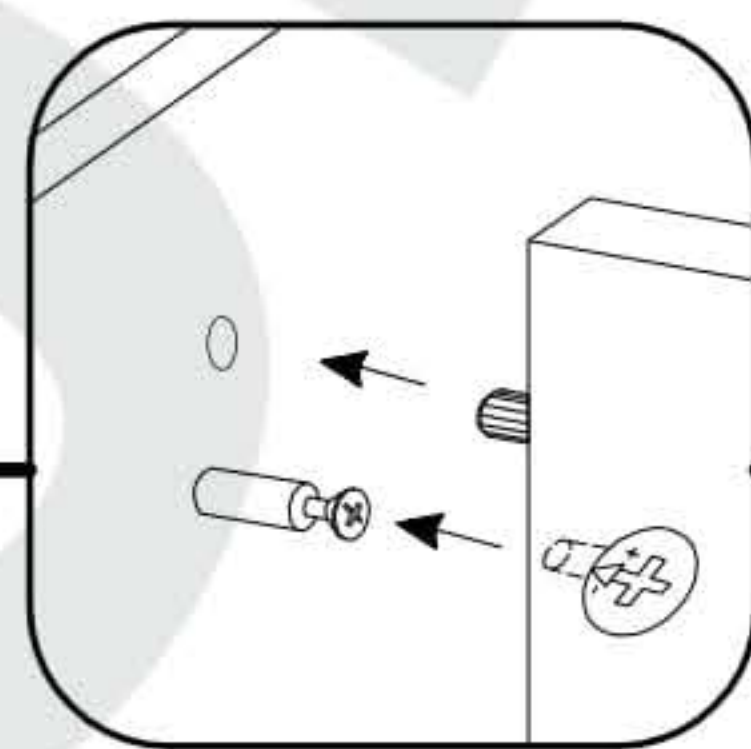
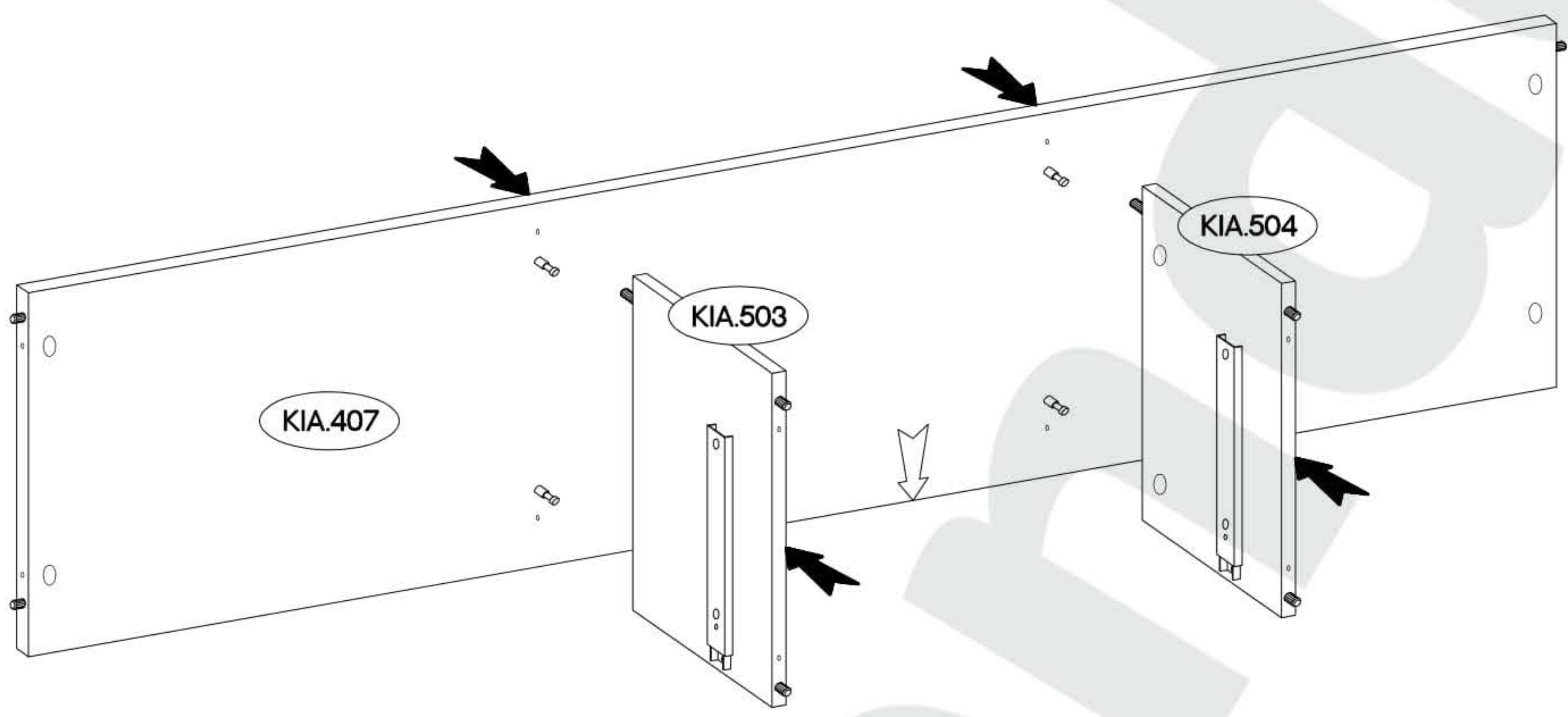
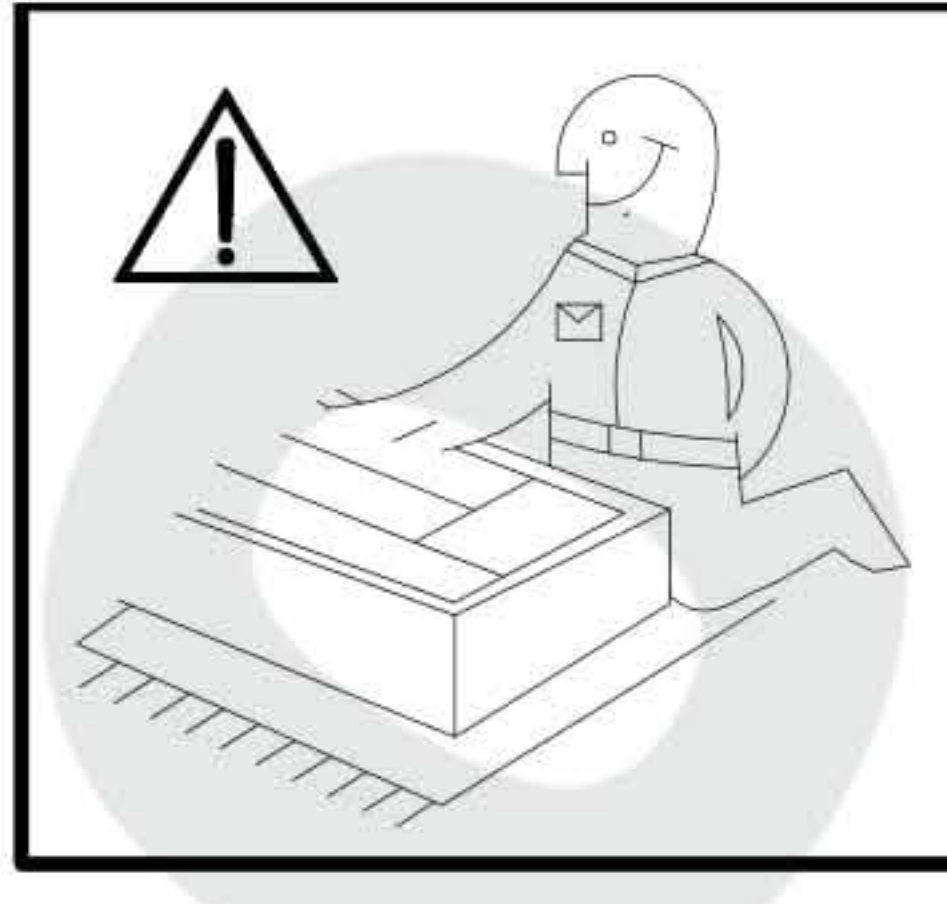

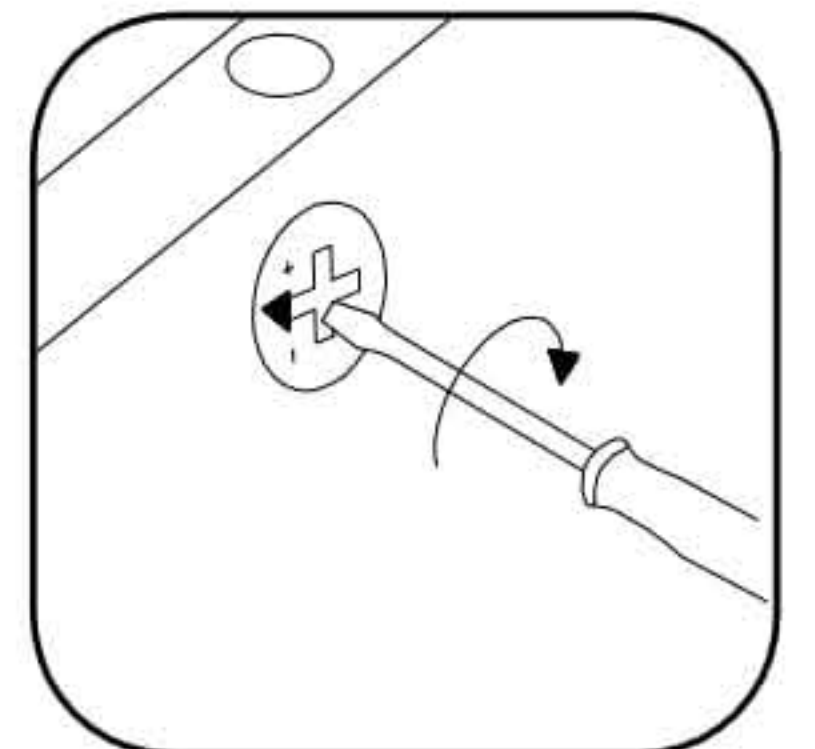
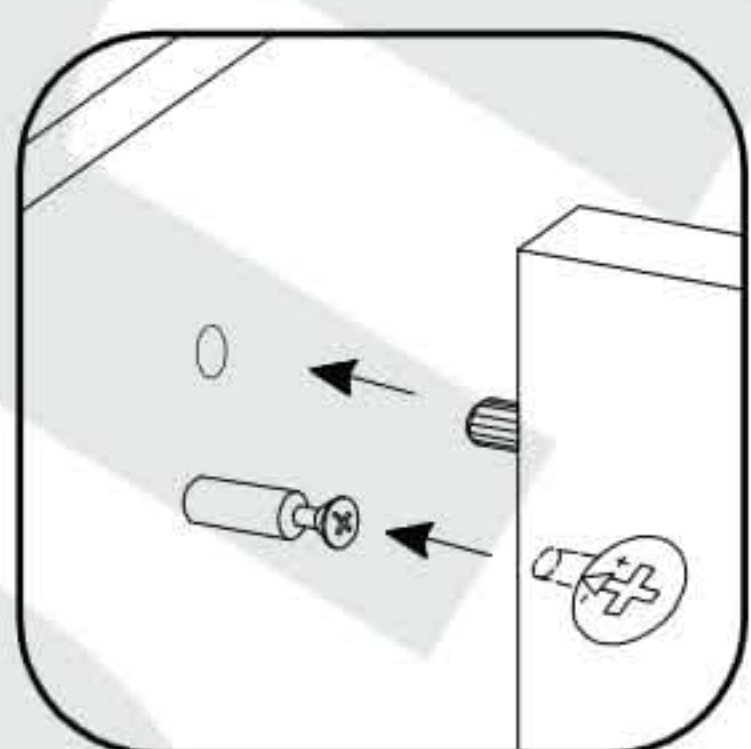
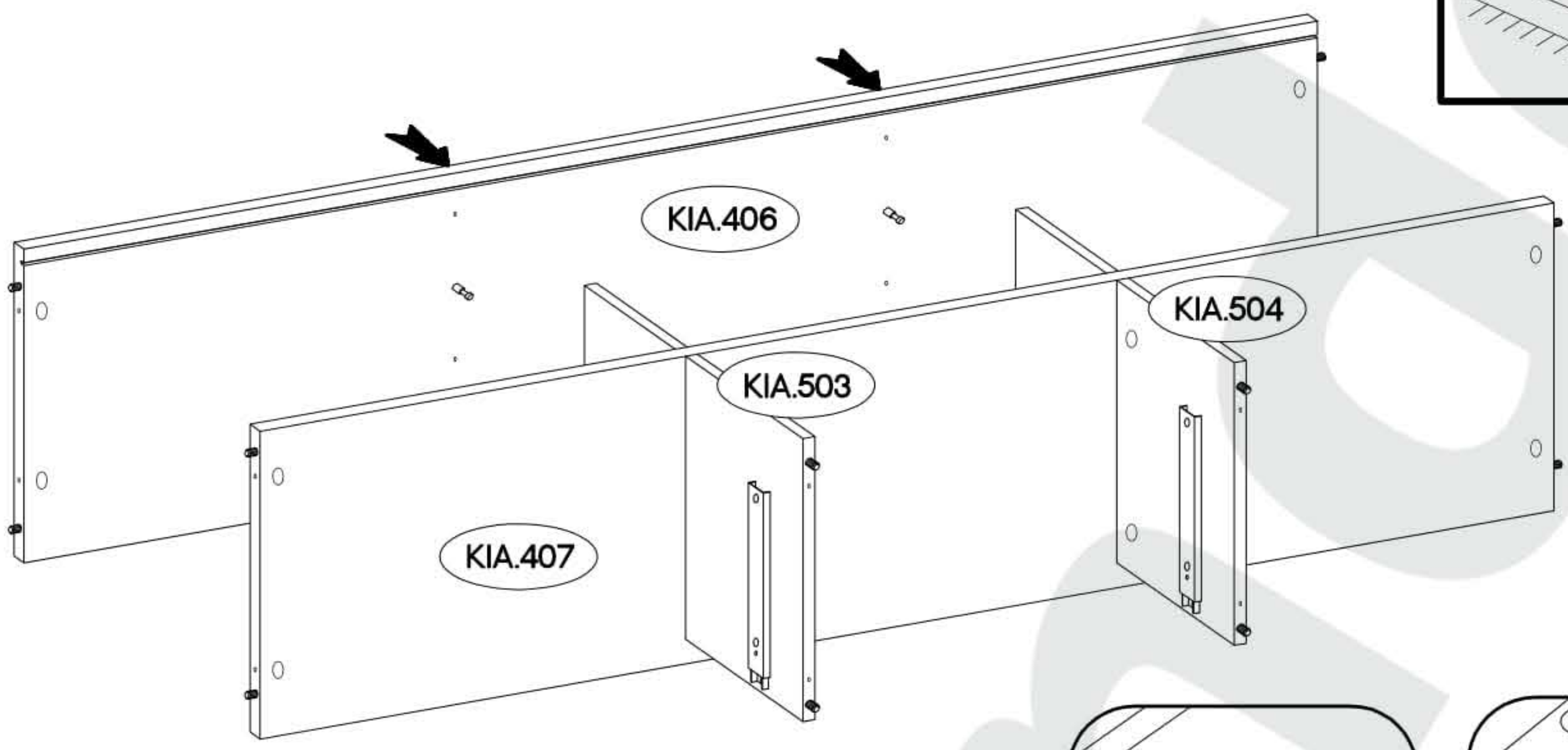
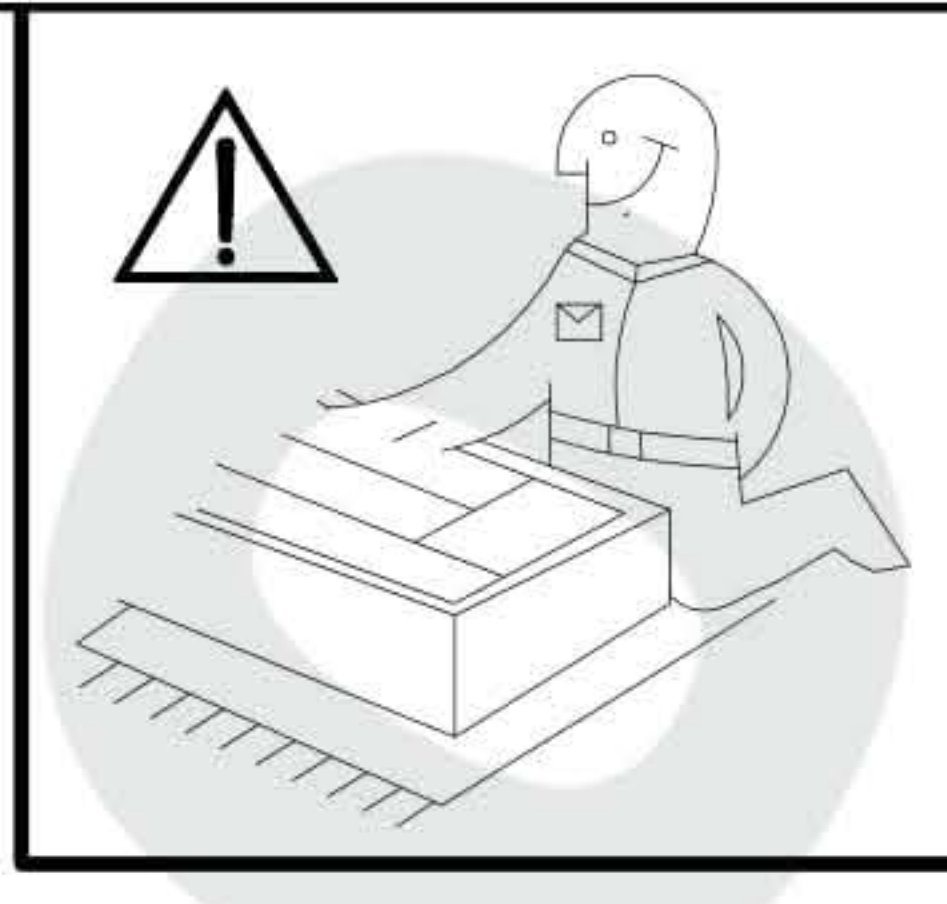

6,4 x 50mm		
	B	O
	4	1

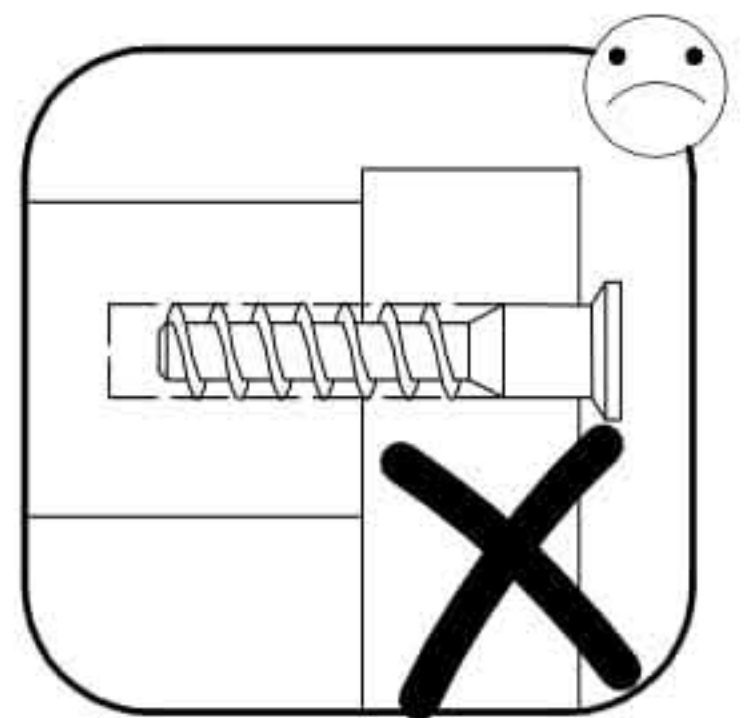
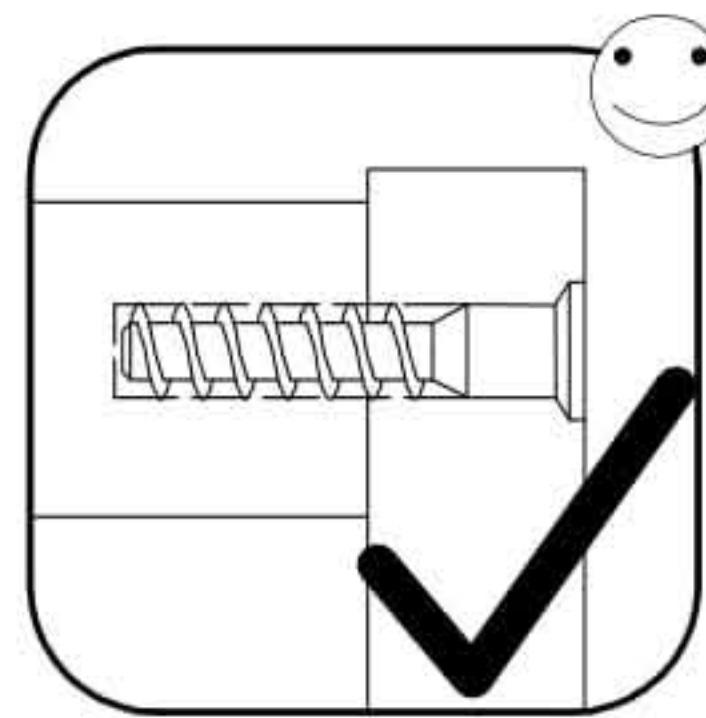
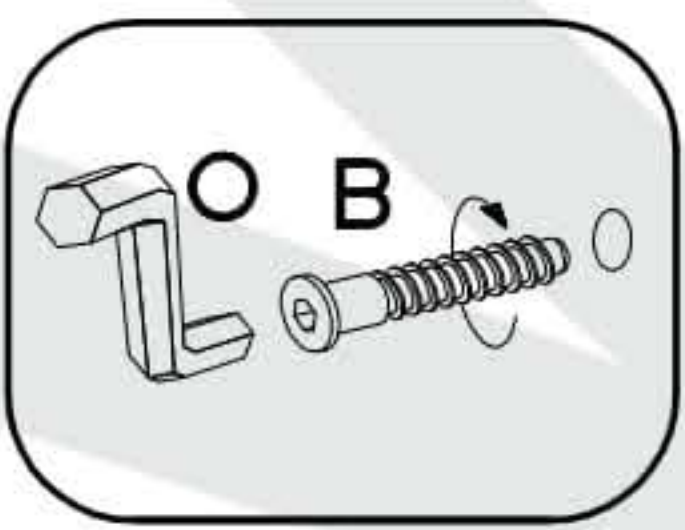
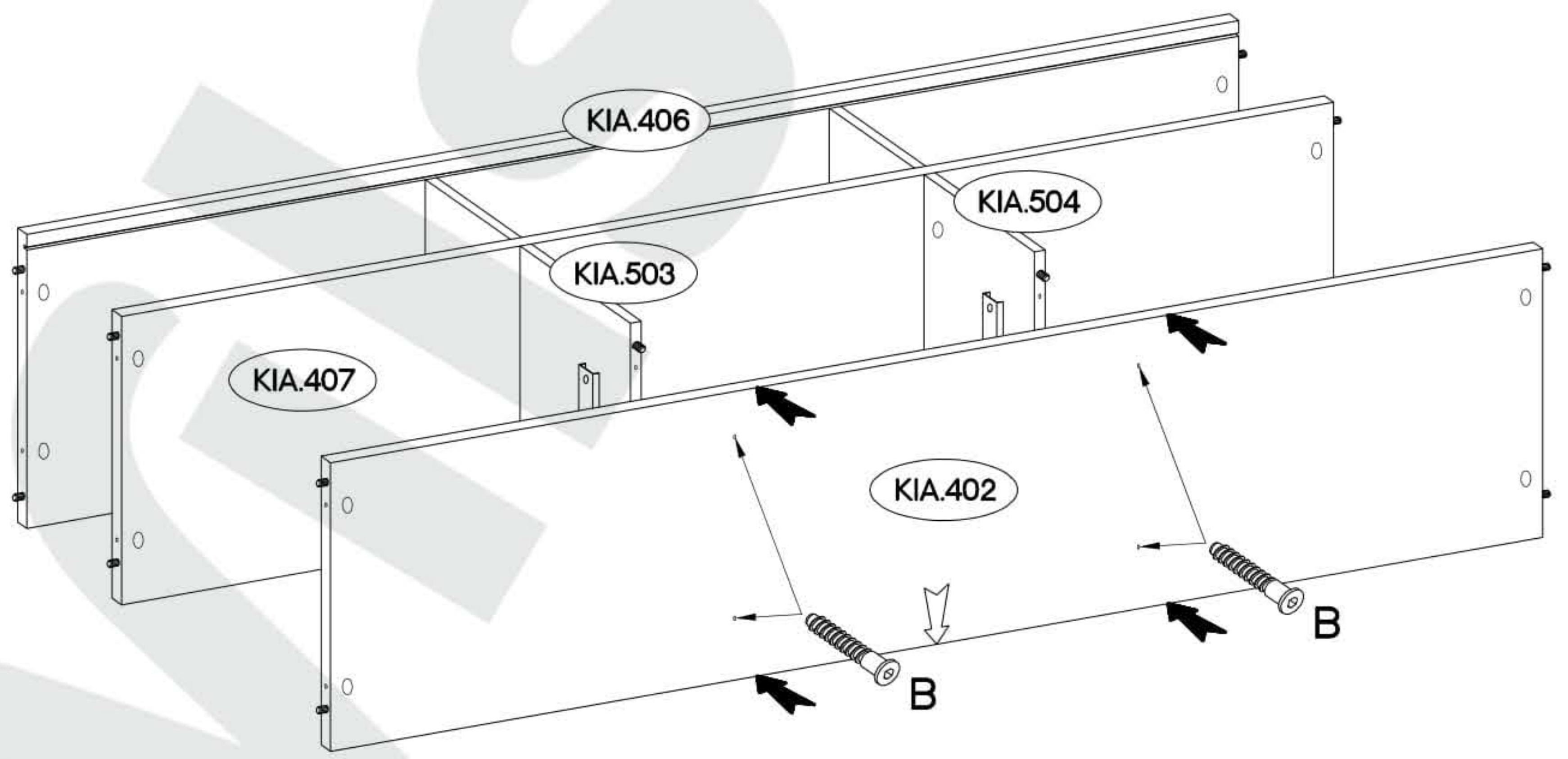

14

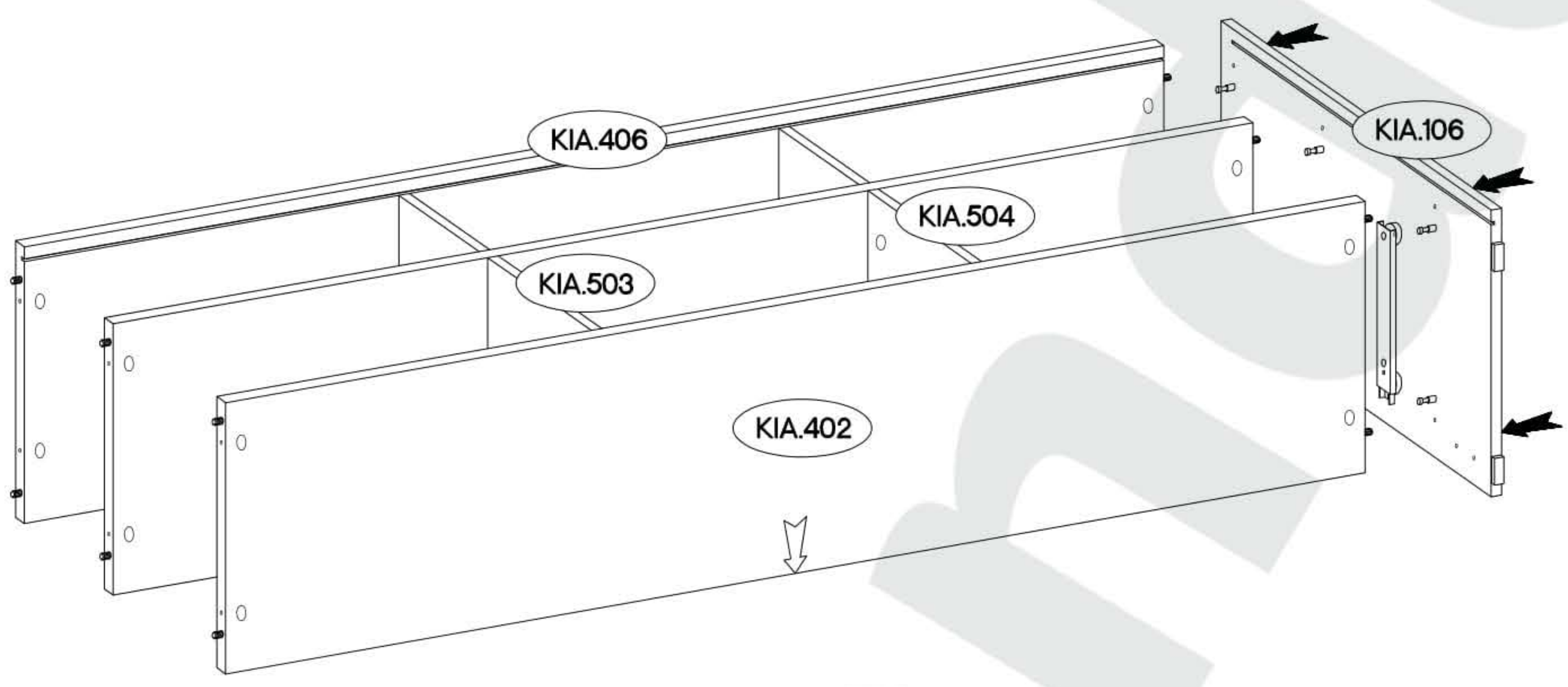
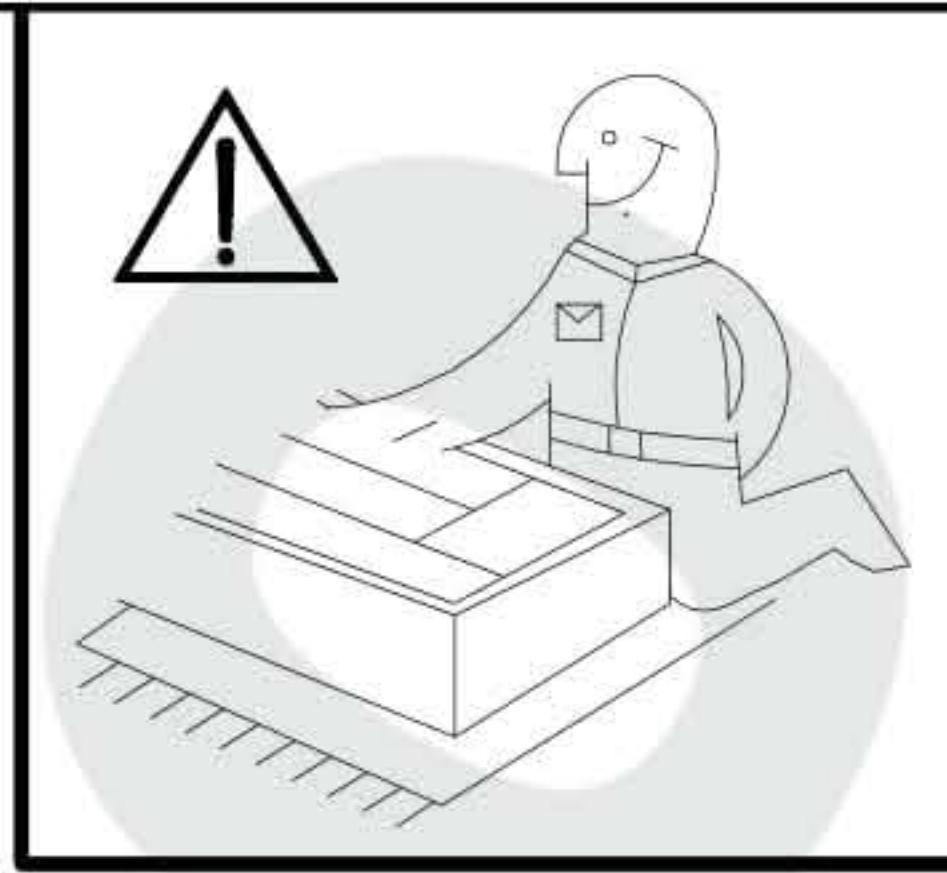

15

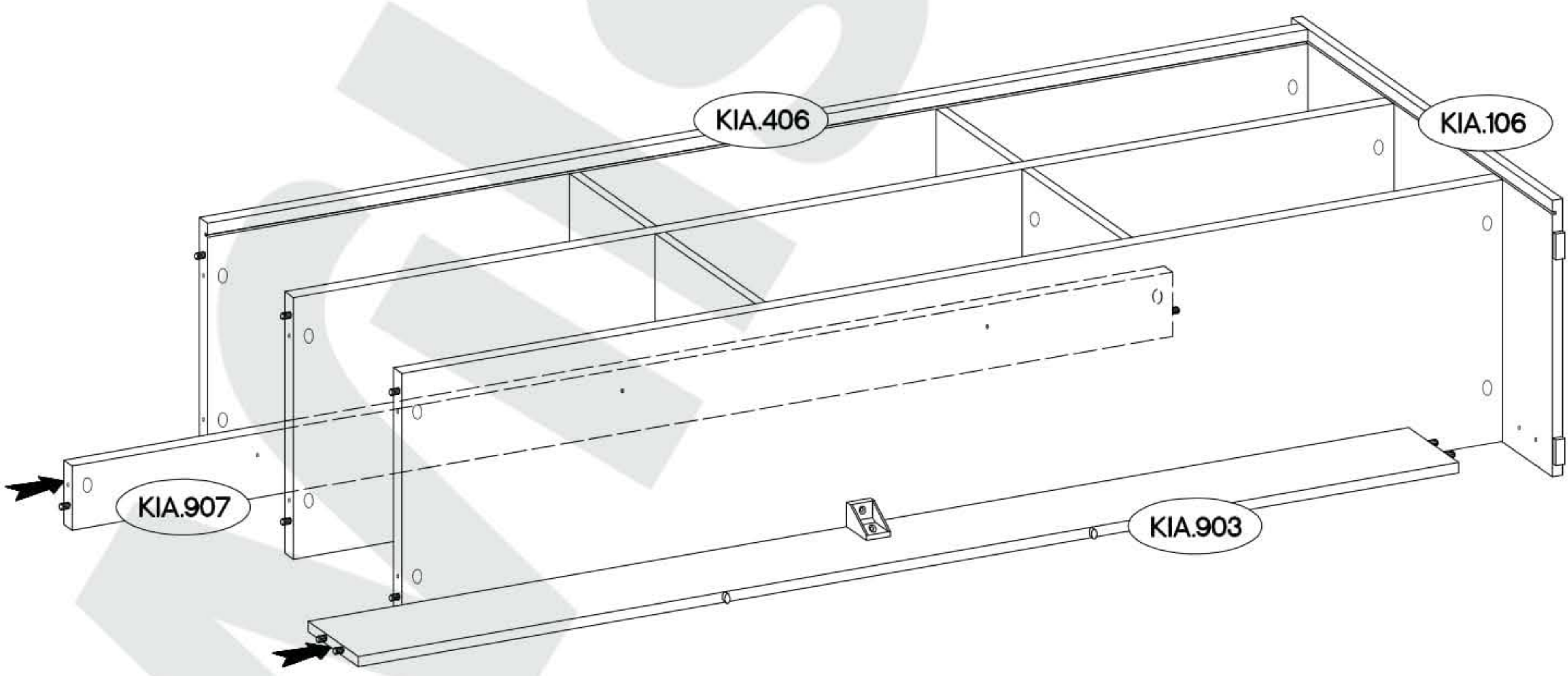
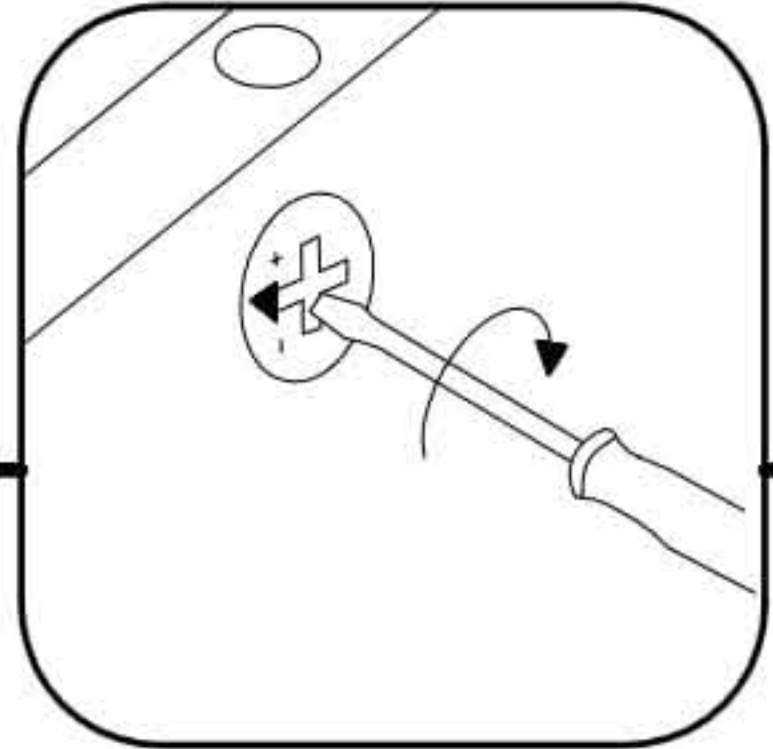
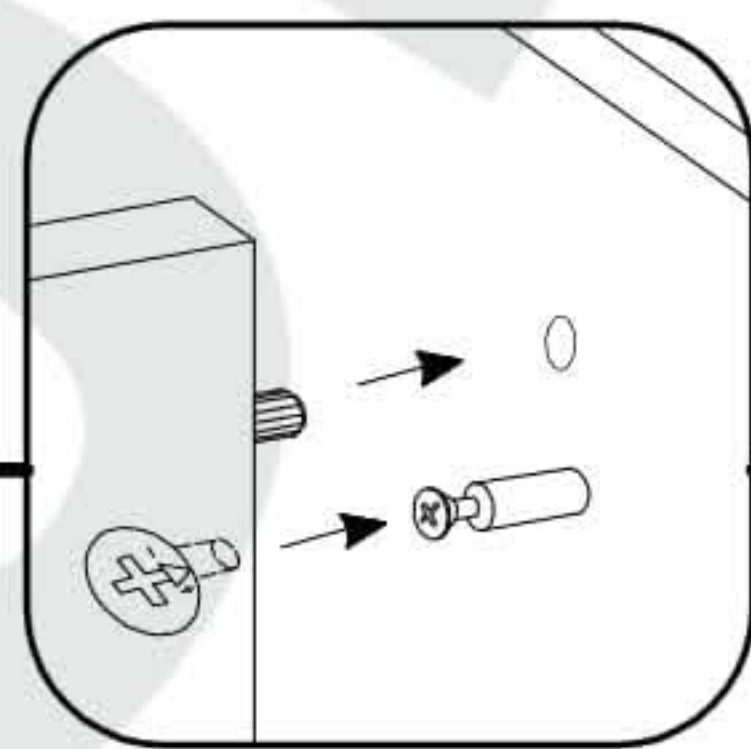

16

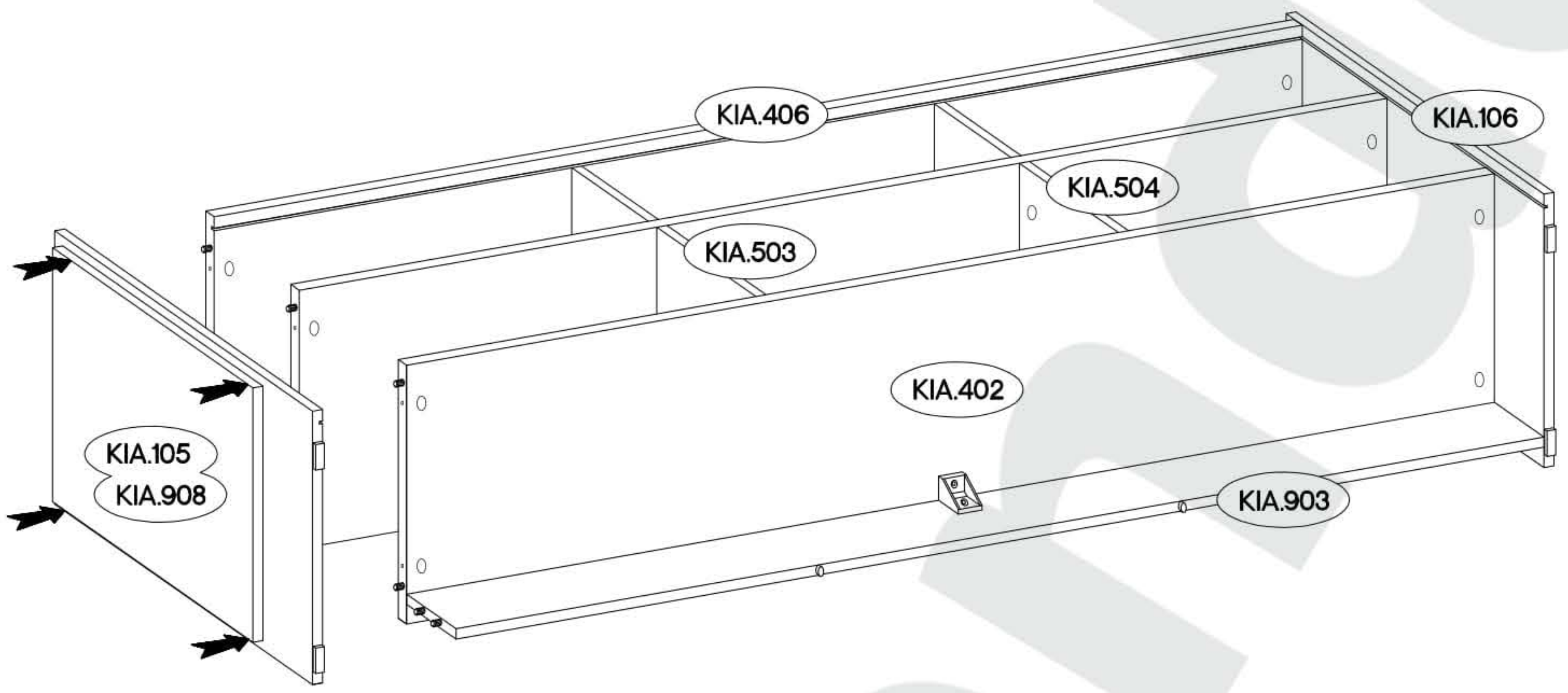
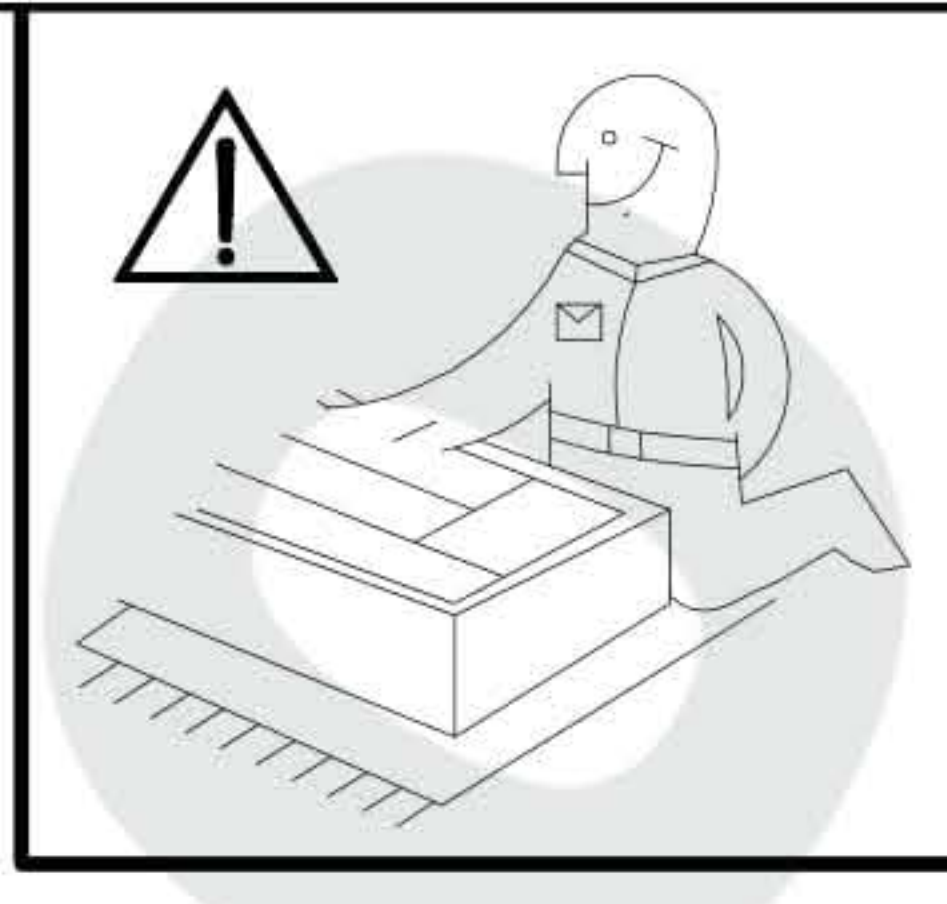
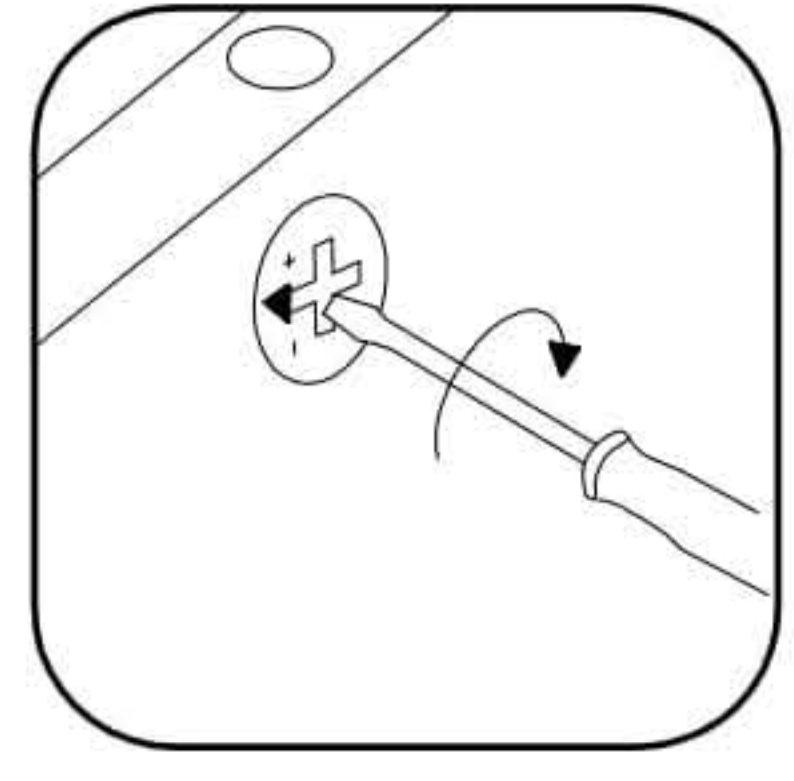
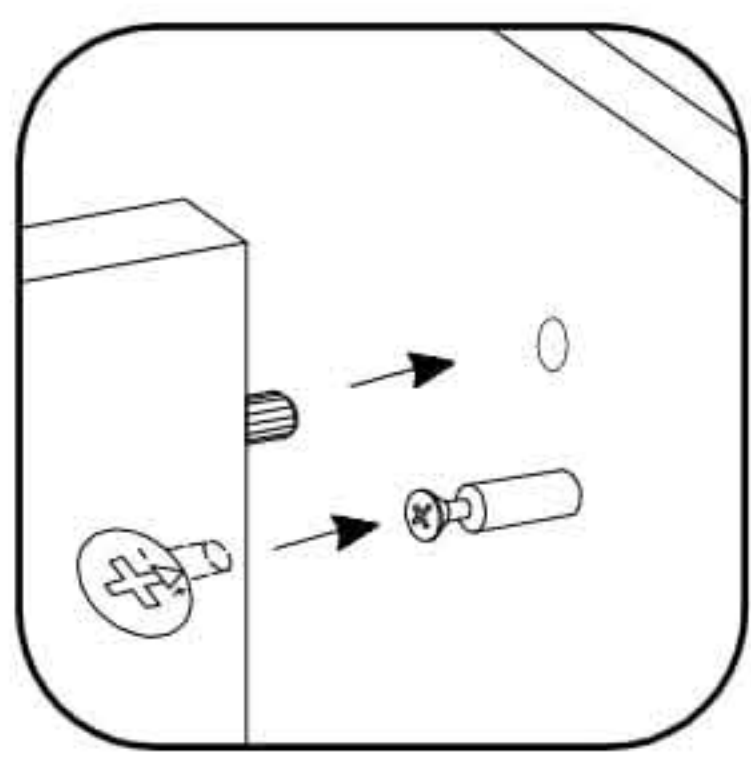



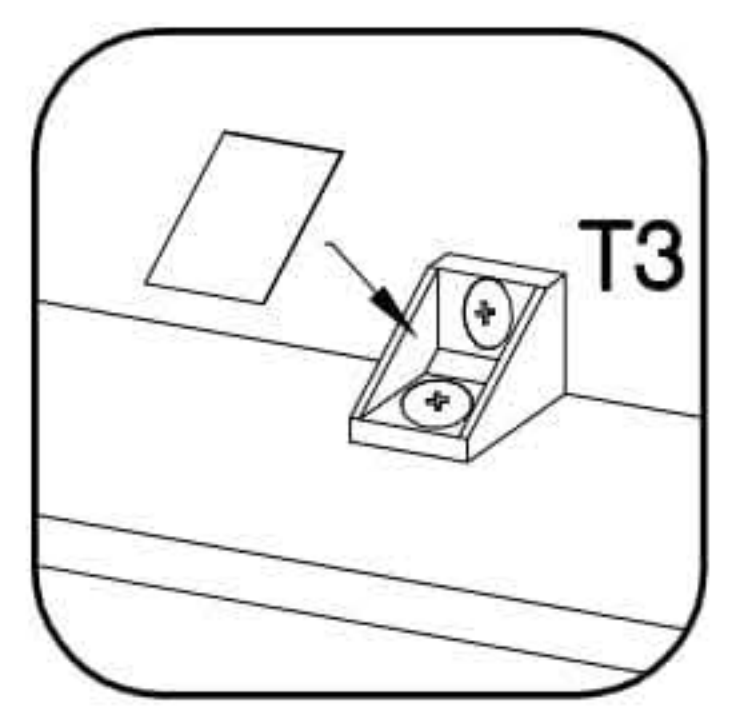
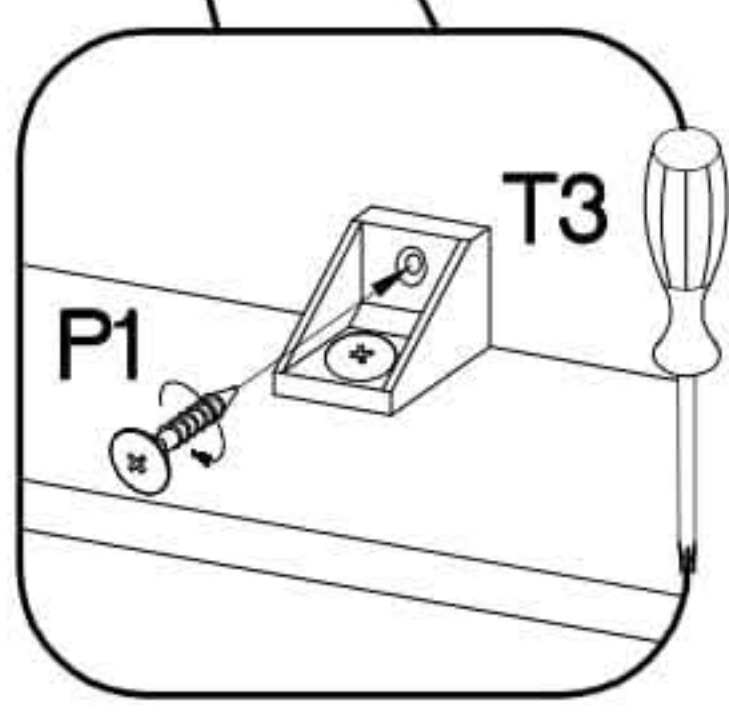
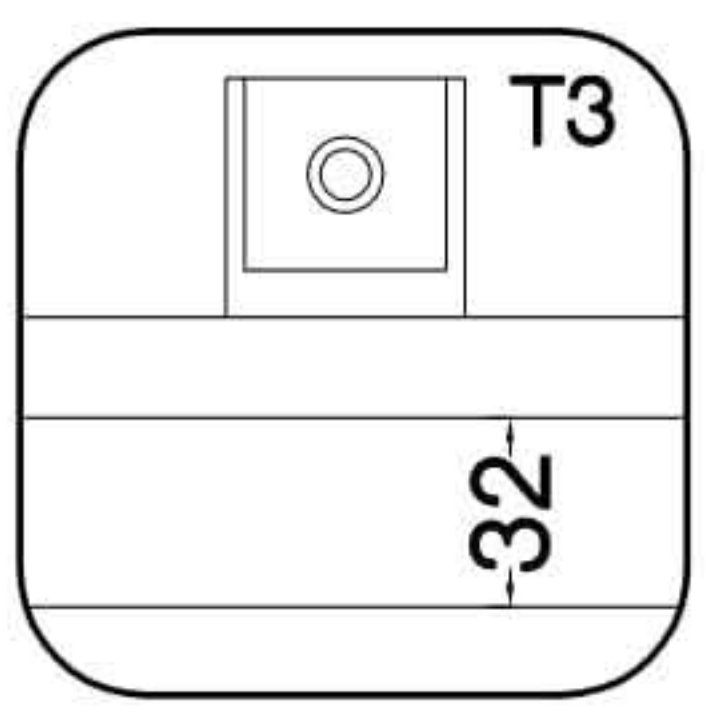
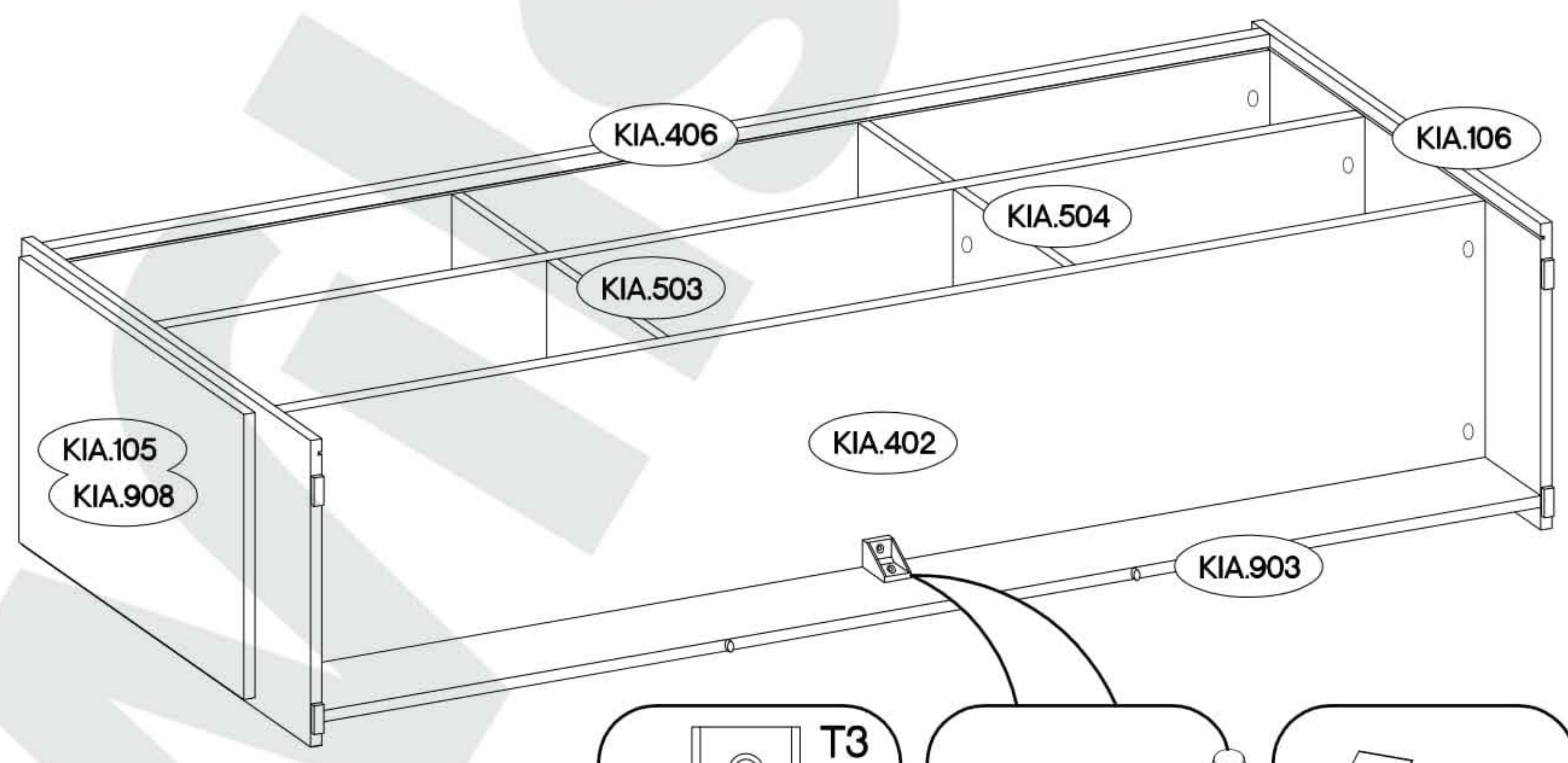
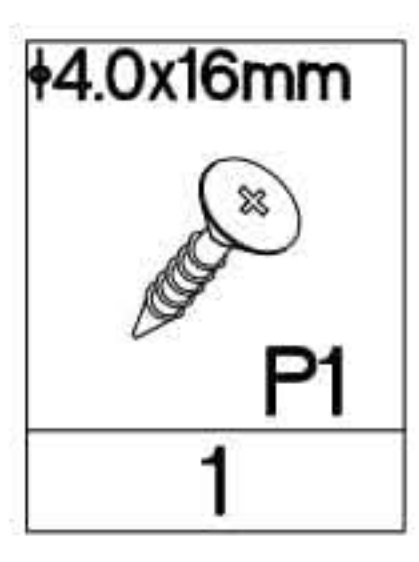

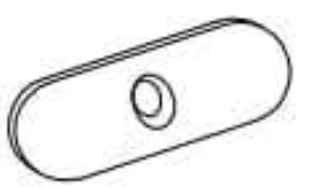
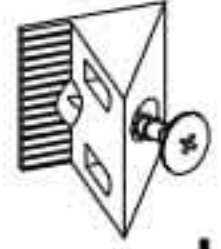

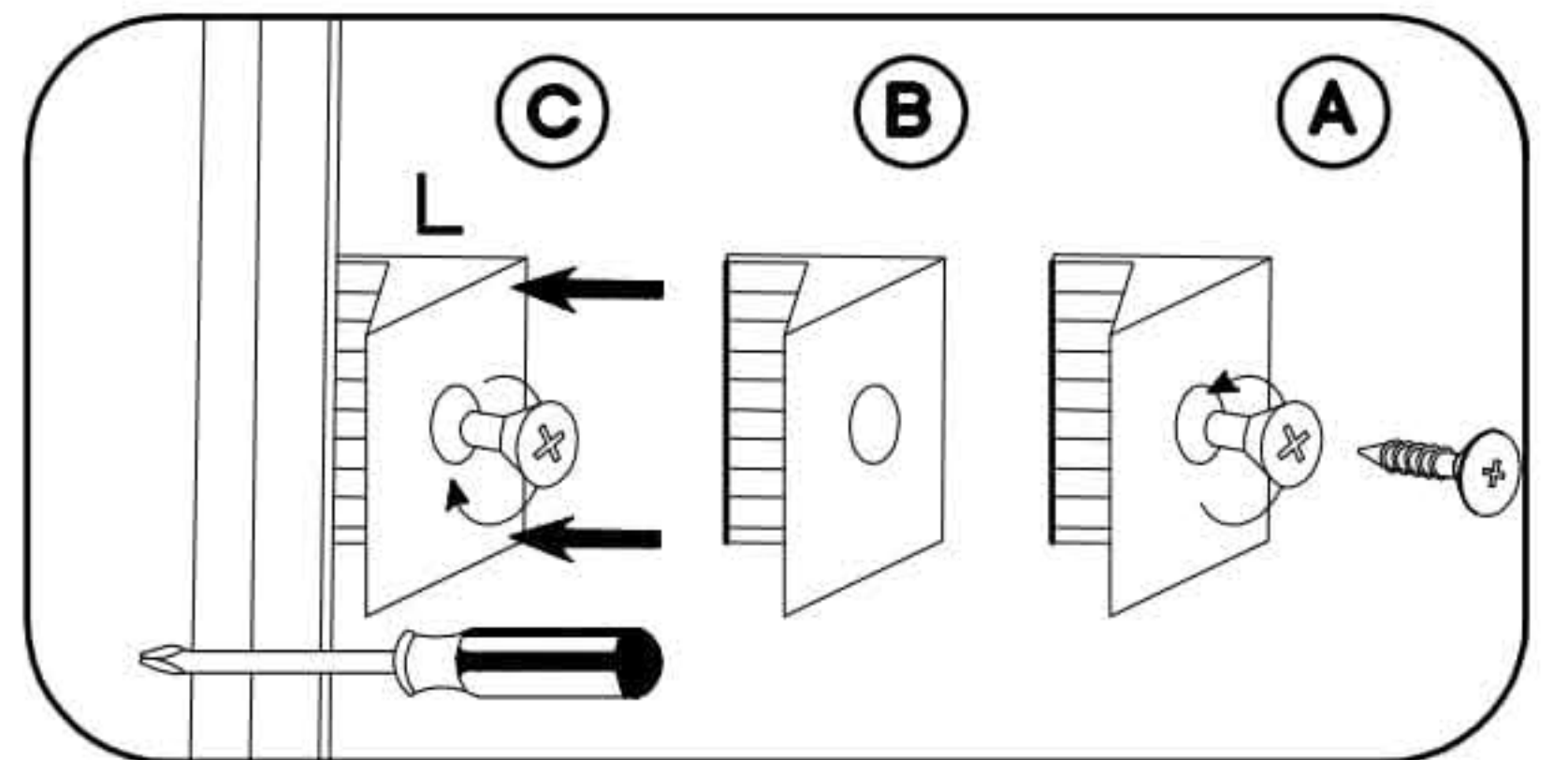
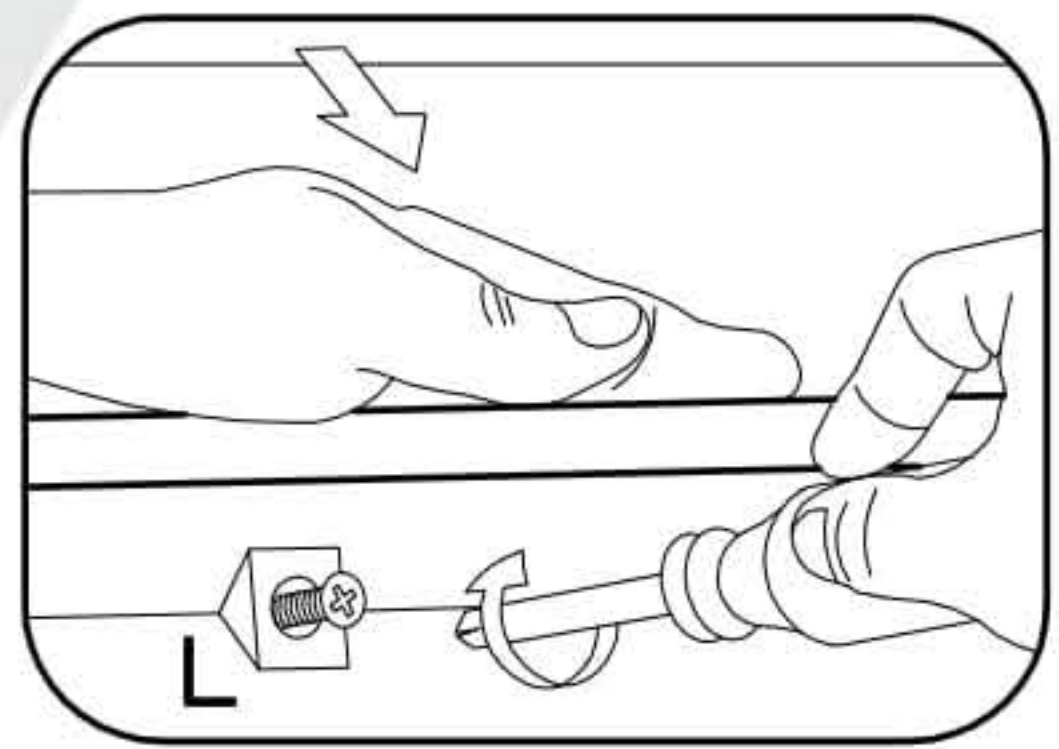
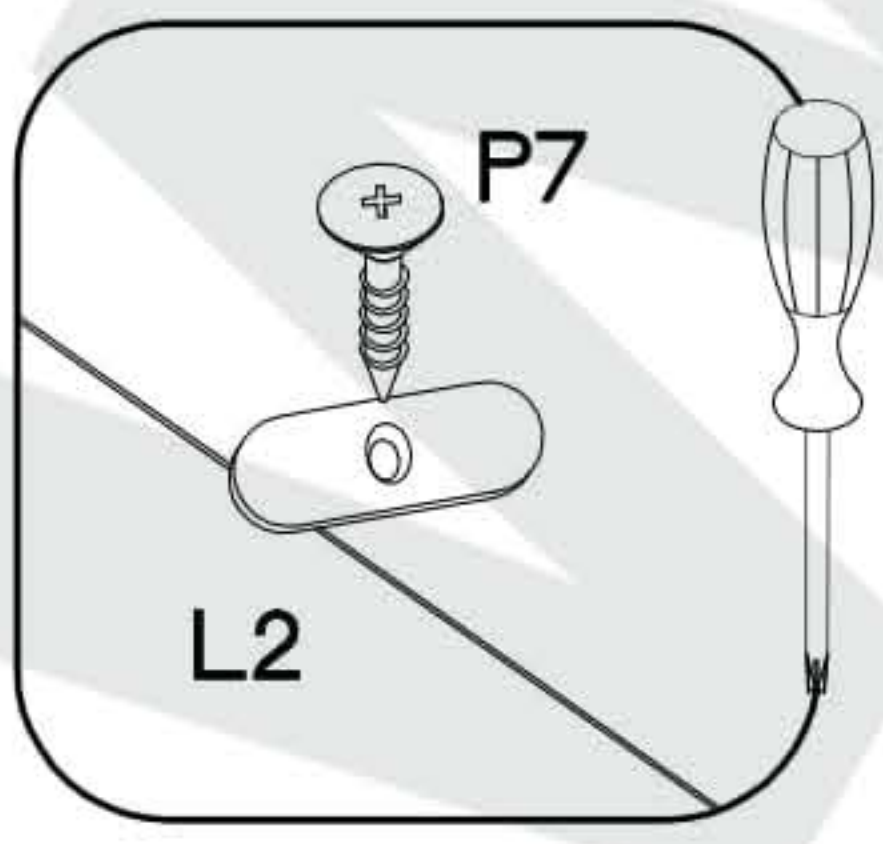
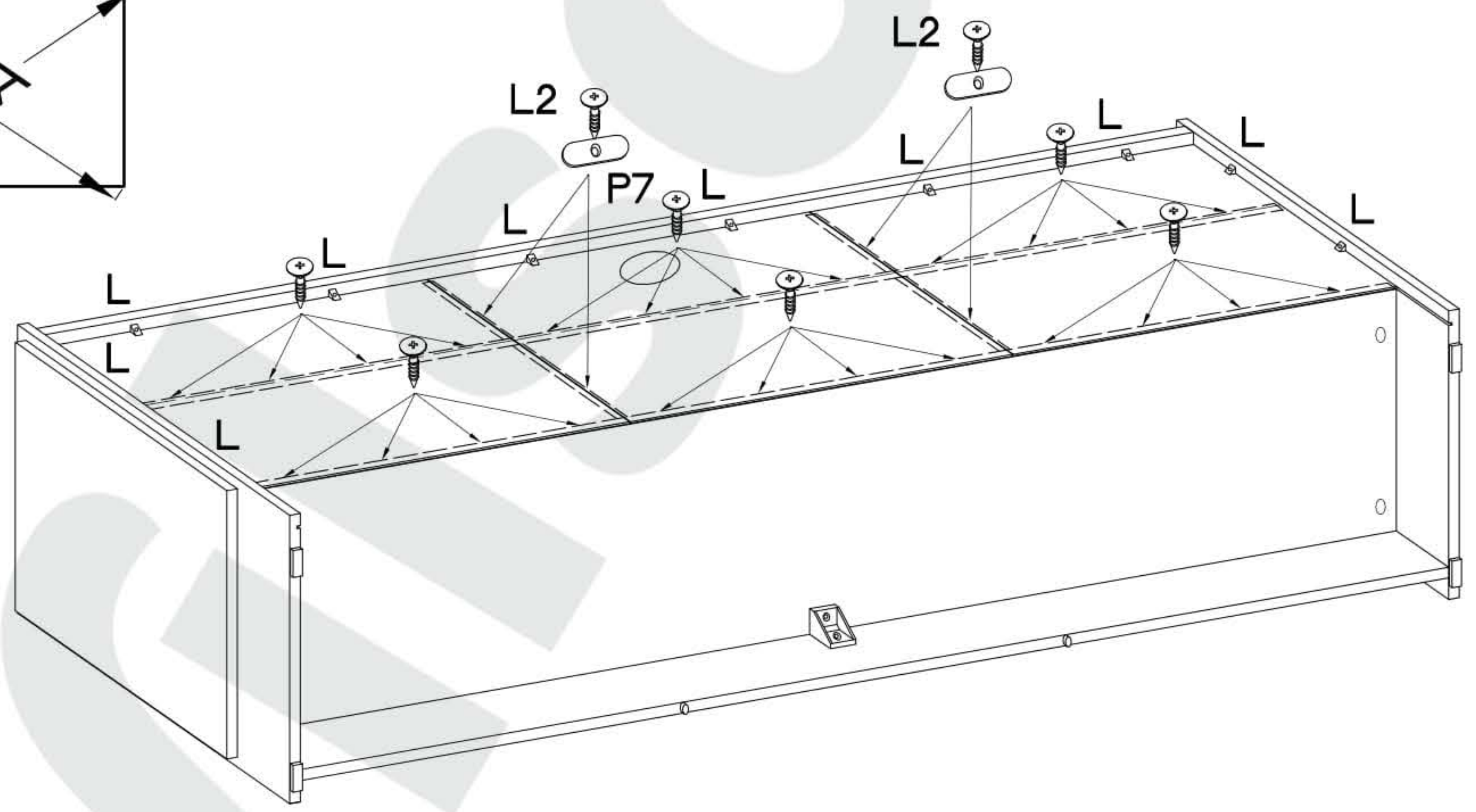
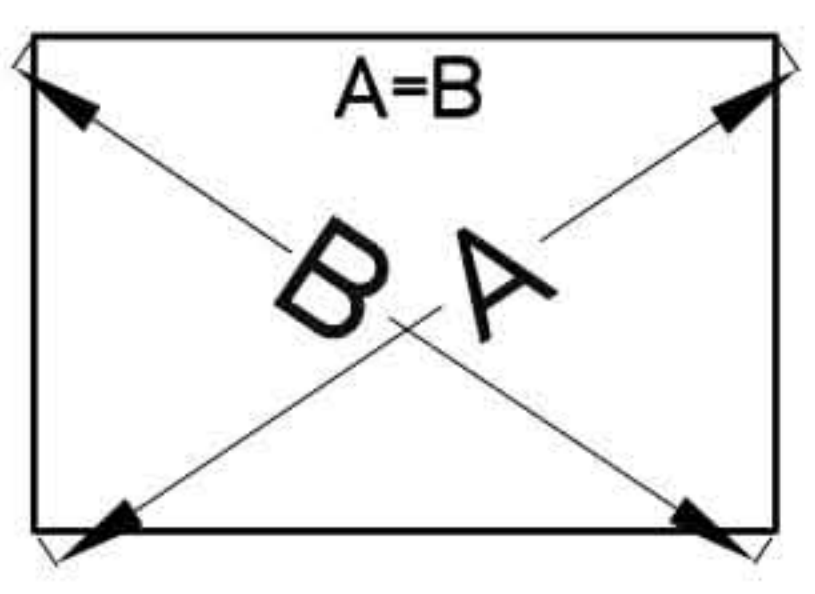
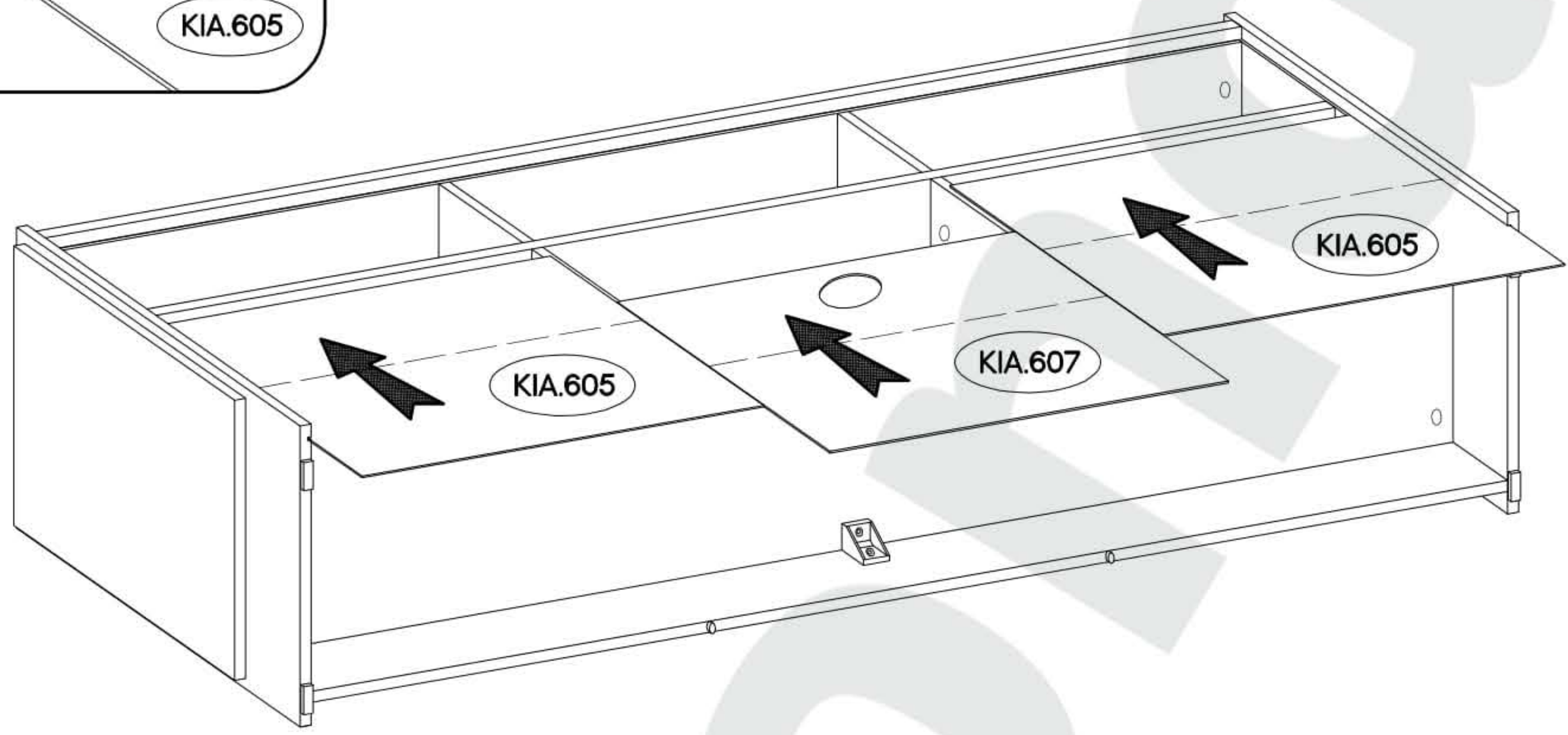
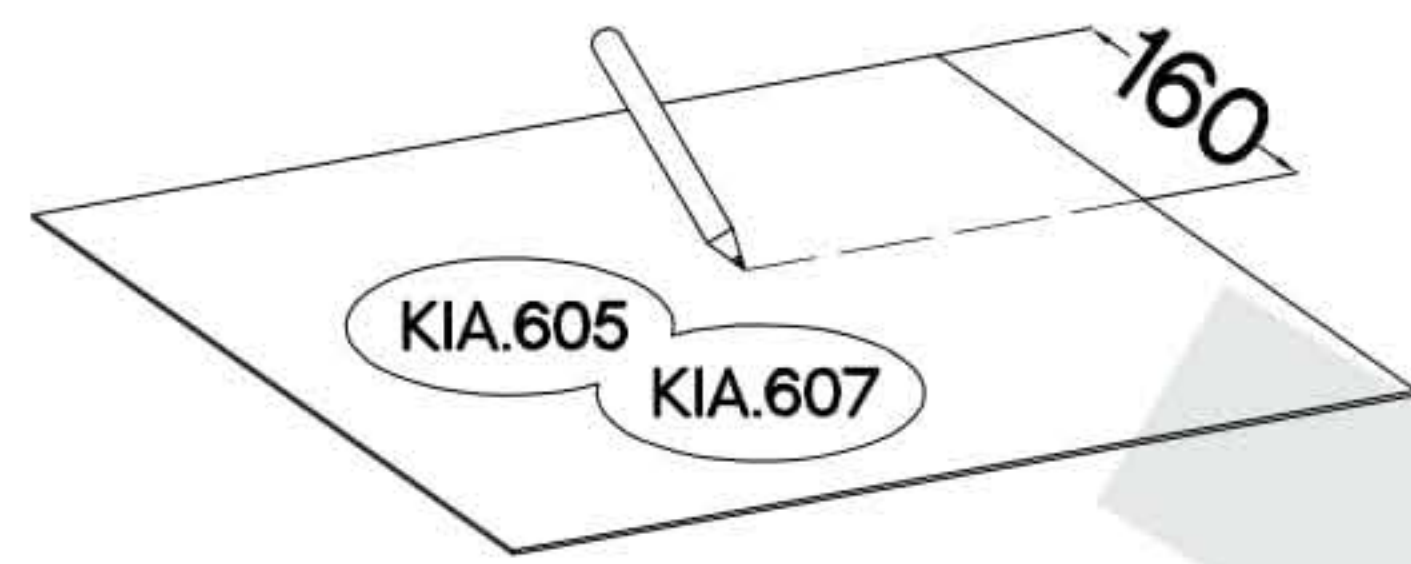
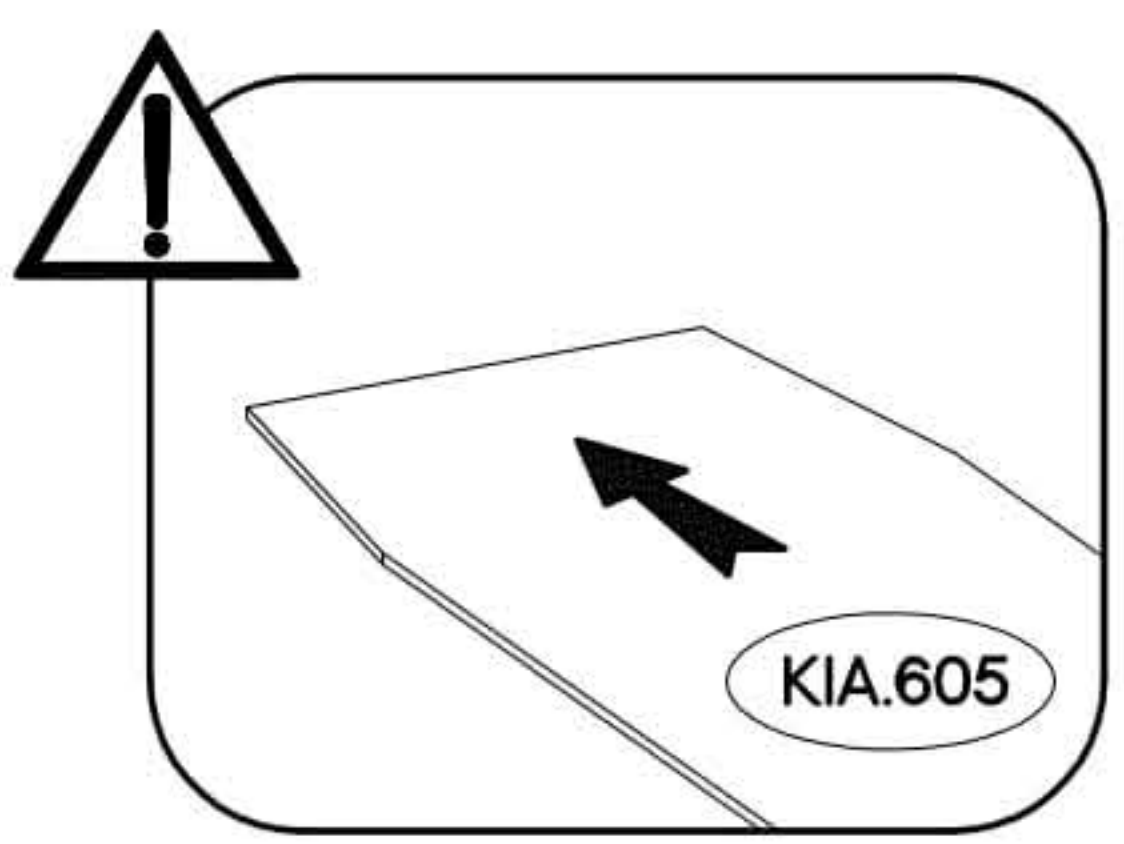
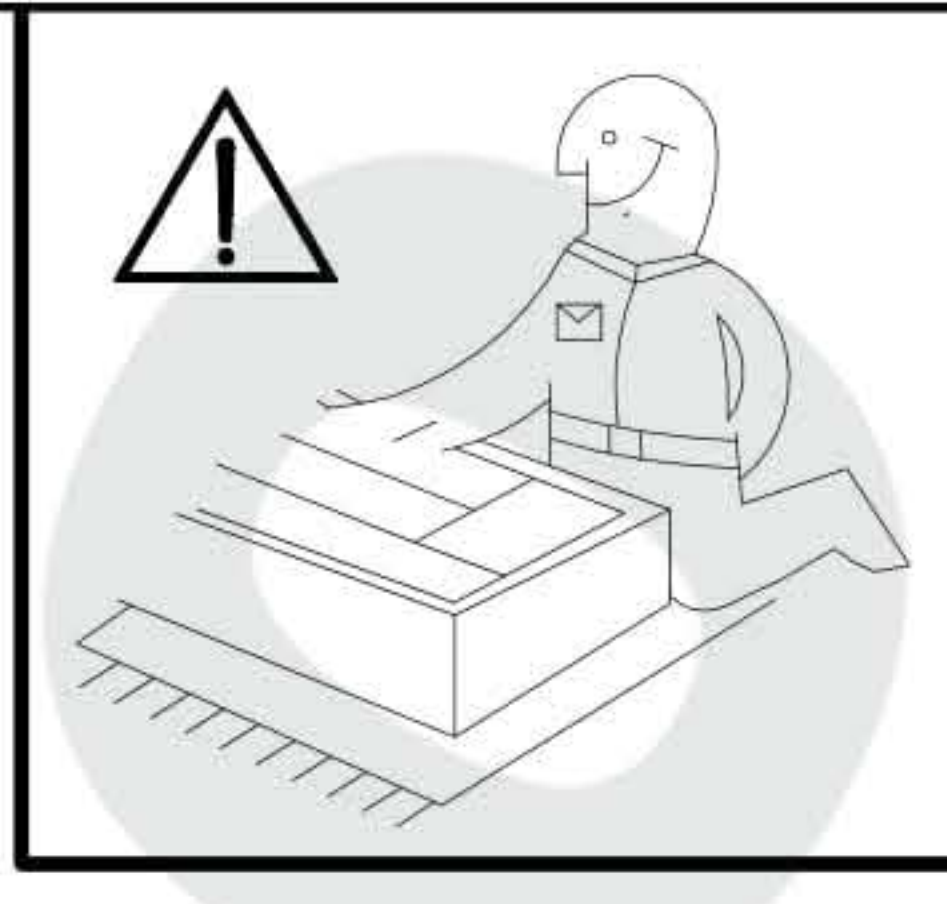
17



±3.0x20mm  P7 26	 L2 4	 L 10
---	---	---



3.5x25mm BLACK  P25 3	cza.  E 14	art.  E 4	L=128mm  S 3	M4x22mm  U 6	M4x9mm  U1 6
--	--	---	--	---	--

