

KOMODA 180

PL> INSTRUKCJA MONTAŻU
D >MONTAGEANLEITUNG
GB>ASSEMBLY INSTRUCTIONS
NL>HANDLEIDING VOOR DE MONTAGE
F >MODEL D'EMPLOI
CZ> POKYNY PRO INSTALACI
SK> INSTRUKCJA MONTAŽUNÁVOD

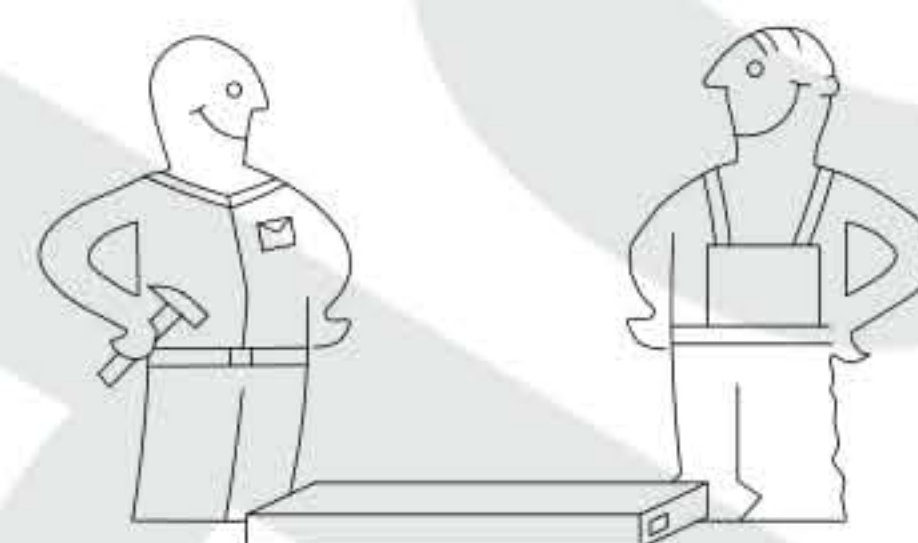

NA INŠTALÁCIU
HR> UPUTE ZA MONTAŽU
SRB> УПУТСТВО ЗА УГРАДЊУ

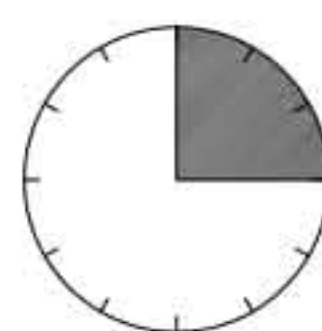

180 minut
 180 minuten
 180 minutes
 180 minutes

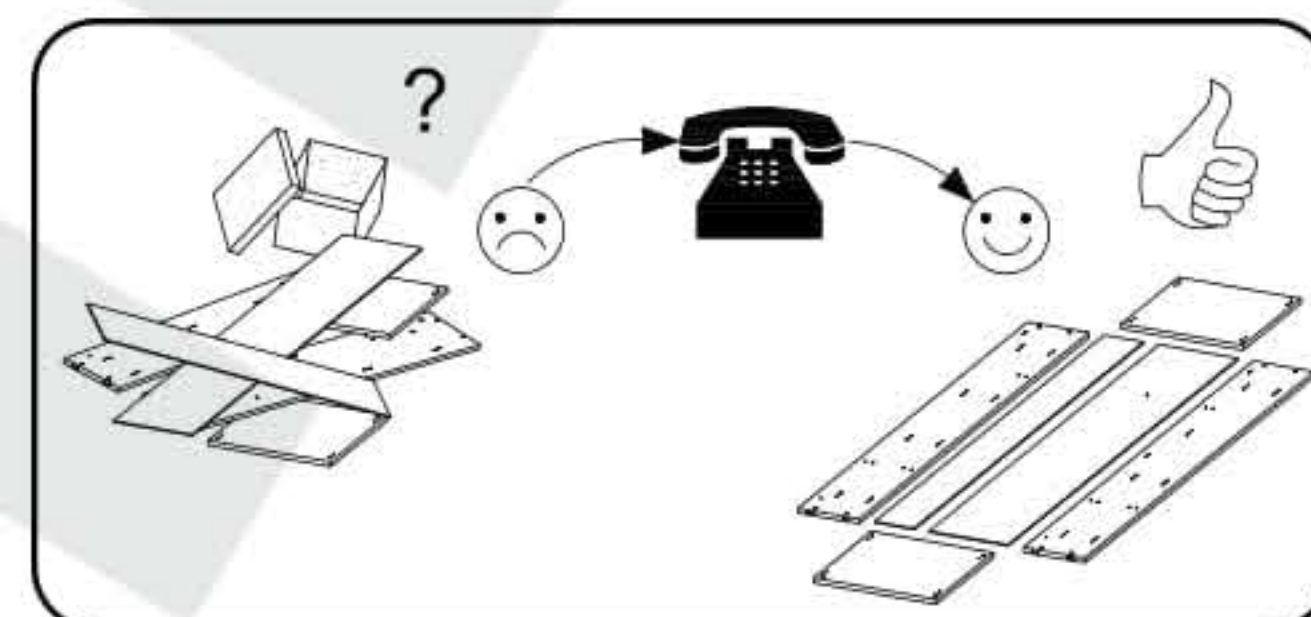
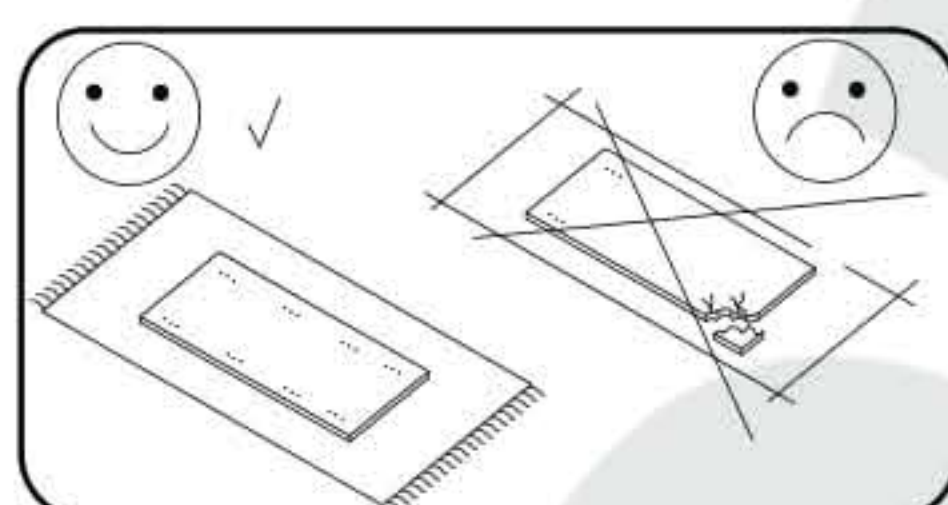
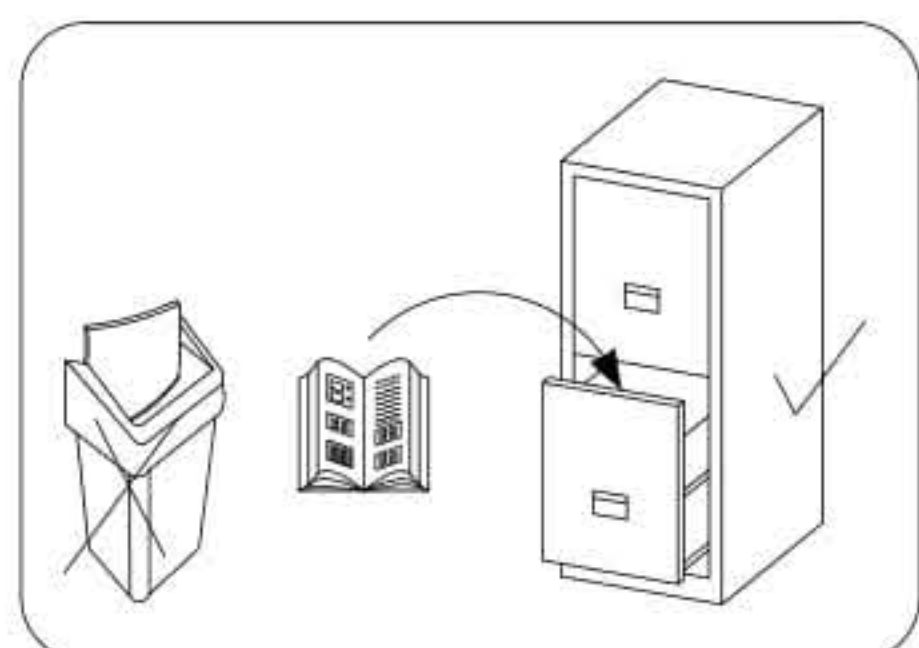
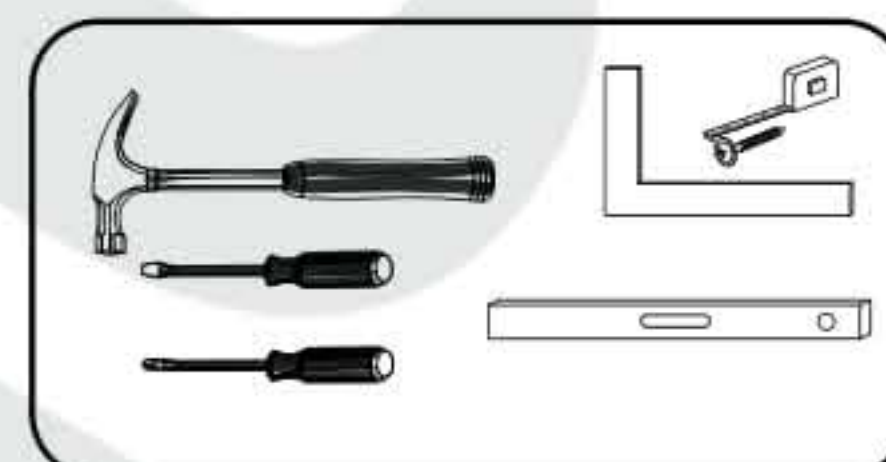

! Uwaga / Achtung / Caution / Opgelet / Attention / !
Pozornost / Pozornost' / Pažnja / Пажња

PL>Czyszczenie należy wykonać wyłącznie za pomocą ściereczki lub lekko nawilżonego ręcznika.
 Nie stosować środków czyszczących do szorowania.

Szanowny kliencie, jeśli podczas montażu stwierdzisz uszkodzenie lub brak części, proszę podaj jej kod alfanumeryczny lub zaznacz ją na instrukcji montażu i prześlij wraz z protokołem reklamacyjnym

D >Bitte nur mit einem Staubtuch oder leicht feuchtem Lappen reinigen. Keine scheuerenden Putzmittel verwenden.

Sehr geehrter Kunde, sollte ein Teil fehlen oder beschädigt sein, kreuzen Sie dies bitte deutlich auf der Montageanleitung an und schicken Sie die Montageanleitung mit ein.

GB>Please only clean with a duster or a damp cloth. Do not use any abrasive cleaners.

Dear customer, should there be any piece missing or damaged, kindly mark this piece clearly on the attached assembly instructions and return them to us.

NL>Reinig alleen met een stofdoek of een lichtjes vochtige doek. Gebruik geen schurende poetsmiddelen.

Geachte klant, in het geval van beschadiging of ontbrekende onderdelen tijdens de montage, gelieve de alfanumerieke code in de montagehandleiding te vermelden of te markeren en samen met het klachtenprotocol mee te sturen

F >Le nettoyage se fait uniquement à l'aide d'un torchon ou d'une serviette légèrement mouillée.

Cher client, en cas de dommages ou de pièces manquantes lors du montage, veuillez fournir ou marquer le code alphanumérique dans le manuel de montage et l'envoyer avec le protocole de réclamation

CZ>Čištění by mělo být prováděno pouze hadříkem nebo mírně navlhčeným hadříkem.
Nepoužívejte abrazivní čisticí prostředky.

Vážený zákazníku, pokud při montáži zjistíte poškozený nebo chybějící díl, uveďte jeho alfanumerický kód nebo jej označte v montážním návodu a zašlete spolu s reklamačním protokolem

SK>Čistenie by sa malo vykonávať iba handričkou alebo mierne navlhčenou utierkou. Nepoužívajte čistiace prostriedky na drhnutie..

Vážený zákazník, ak pri montáži nájdete poškodený alebo chýbajúci diel, uveďte jeho alfanumerický kód alebo ho označte na montážnom návode a zašlite spolu s reklamačným protokolom

HR>Čišćenje se smije vršiti samo krpom ili blago navlaženim ručnikom. Nemojte koristiti sredstva za čišćenje.













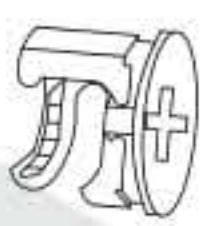



Poštovani kupče, ako tijekom sastavljanja nađete oštećeni dio ili dio koji nedostaje, molimo da dostavite njegov alfanumerički kod ili ga označite u priručniku za sastavljanje i pošaljite ga zajedno s protokolom reklamacije

SRB>Чишћење треба вршити само крпом или благо влажним пешкиром.Немојте користити средства за чишћење.

Поштовани купче, ако током монтаже нађете оштећен или недостаје део, наведите његов алфанумерички код или га означите у приручнику за монтажу и пошаљите га заједно са рекламационим протоколом

Karta serwisowa /Service Karte /Service card /Service kaart /Carte de service/ služební karta/služobný preukaz/servisna kartica/сервисна картица

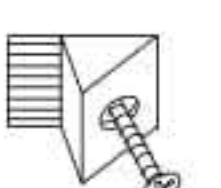
AKCESORIA / ZUBEHÖR / ACCESSORIES / ACCESSOIRES / ACCESSOIRES / PŘÍSLUŠENSTVÍ / DOPLNKY / PRIBOR / ПРИБОР

Ø8.0x35  D	 A	 B	 X	 NM	Ø5.0x30  P1	L-300  PKS	Ø5.0x50  O	4.0  Q
44	28	28	28	4	8	3	4	1
 FNY	Ø3.5x16  H	 S	 Z1	 L1	Ø3.0x30  P2	 I	Ø6.0x35  D1	
5	38	8	4	4	51	9	56	

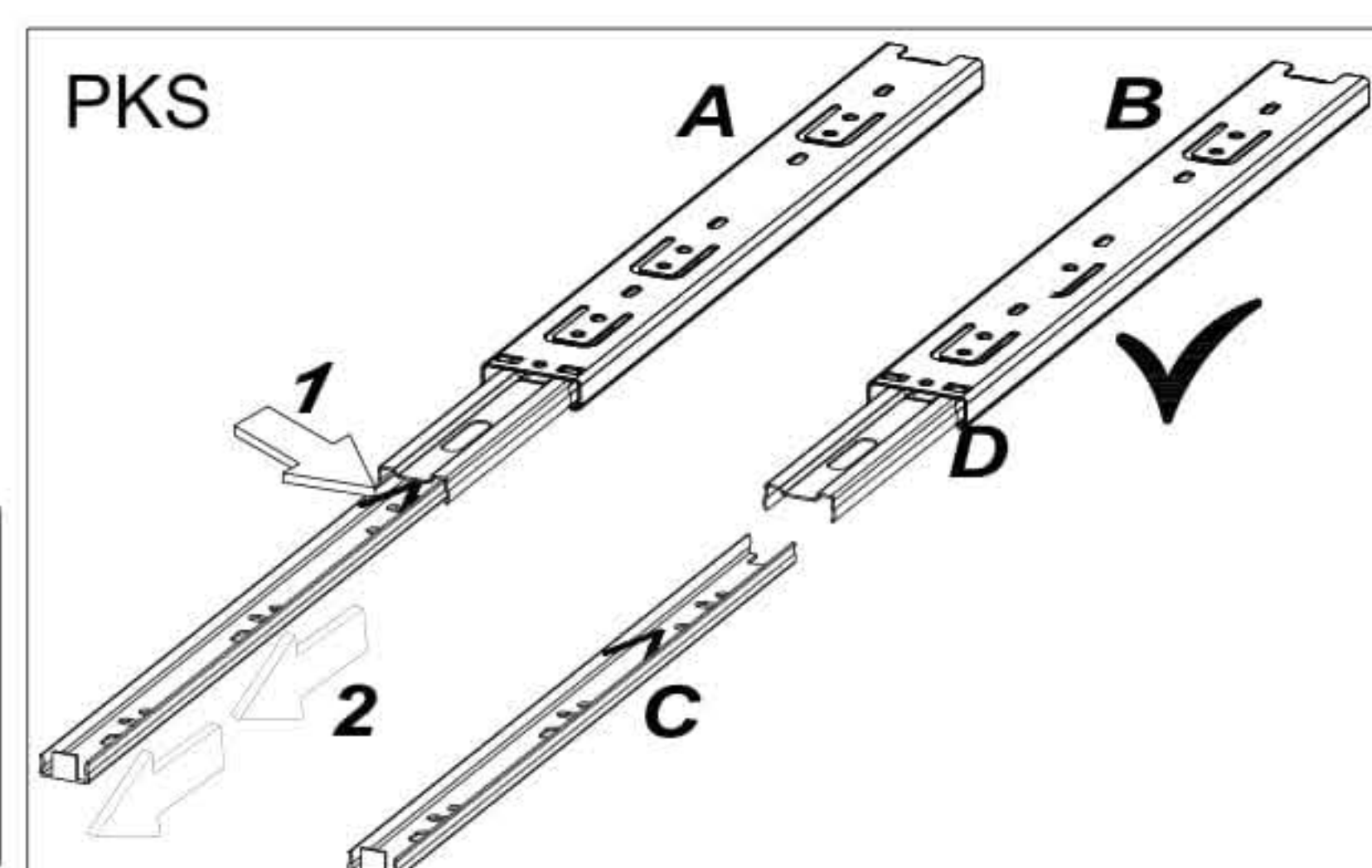
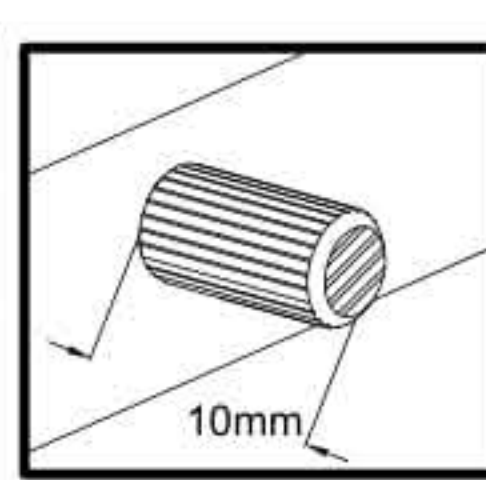
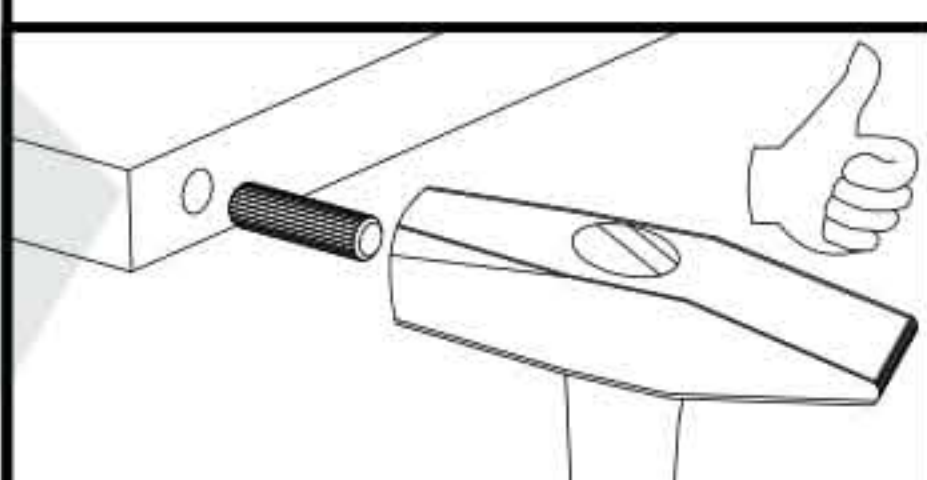
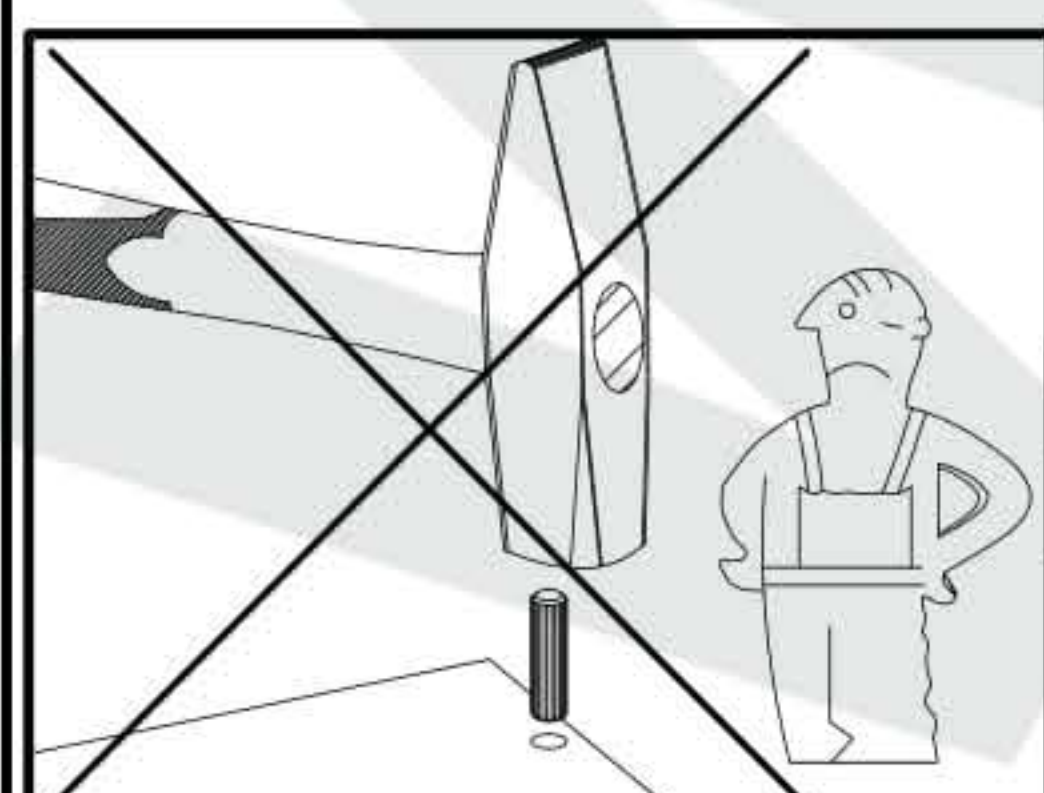

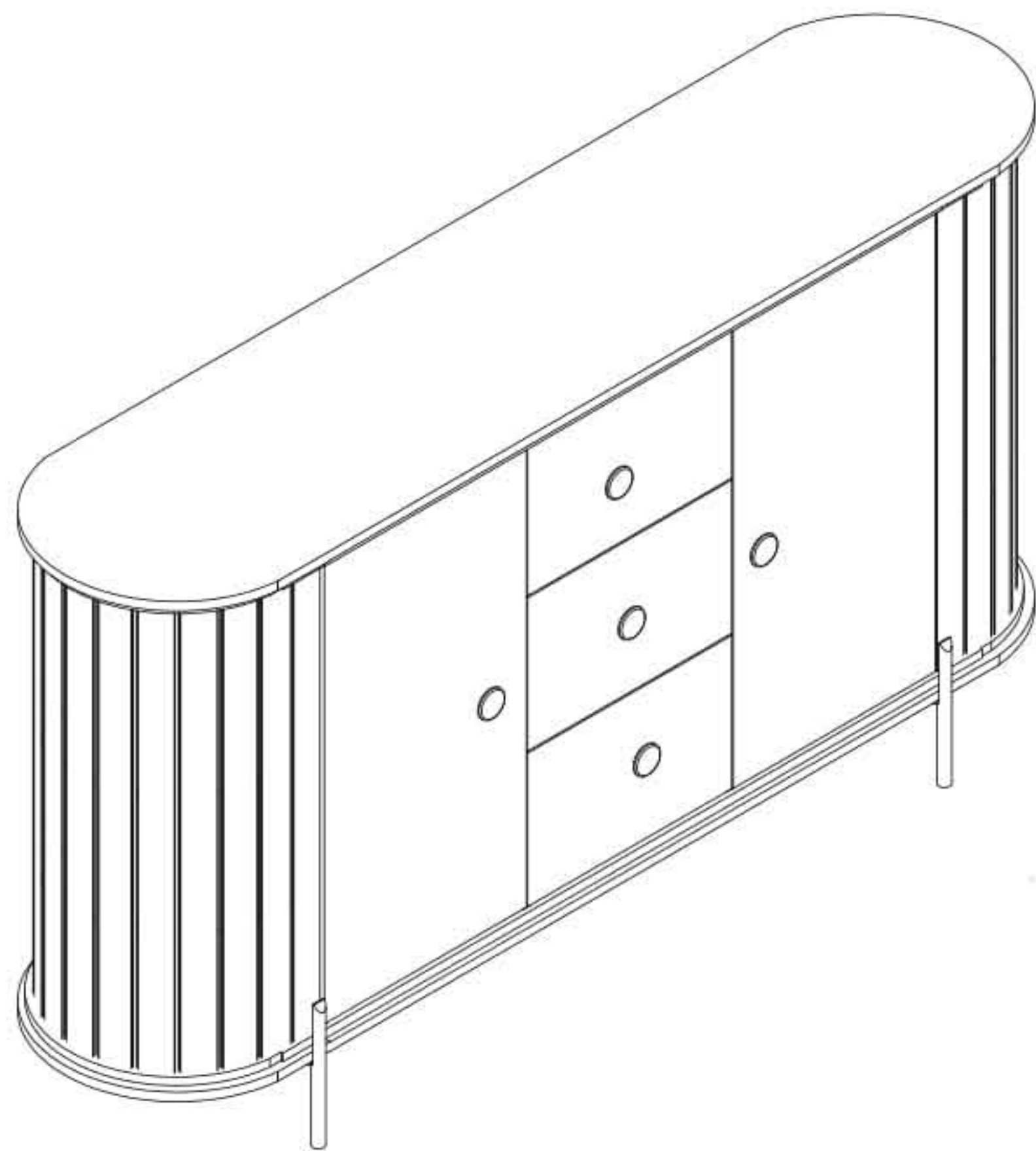

1.	1	1817	402	32
2.	1	1817	402	32
3.	1	660	385	16
4.	1	660	385	16
5.	1	660	350	16
6.	1	660	350	16
7.	2	385	345	16
8.	1	660	1177	16
9.	36	660		16
9A.	2	660		16
9B.	2	660		16
10.	3	216	388	16
11.	1	654	388	16
12.	1	654	388	16
13.	3	300	140	16
14.	3	300	140	16
15.	3	317	140	16
16.	3	305	347	3

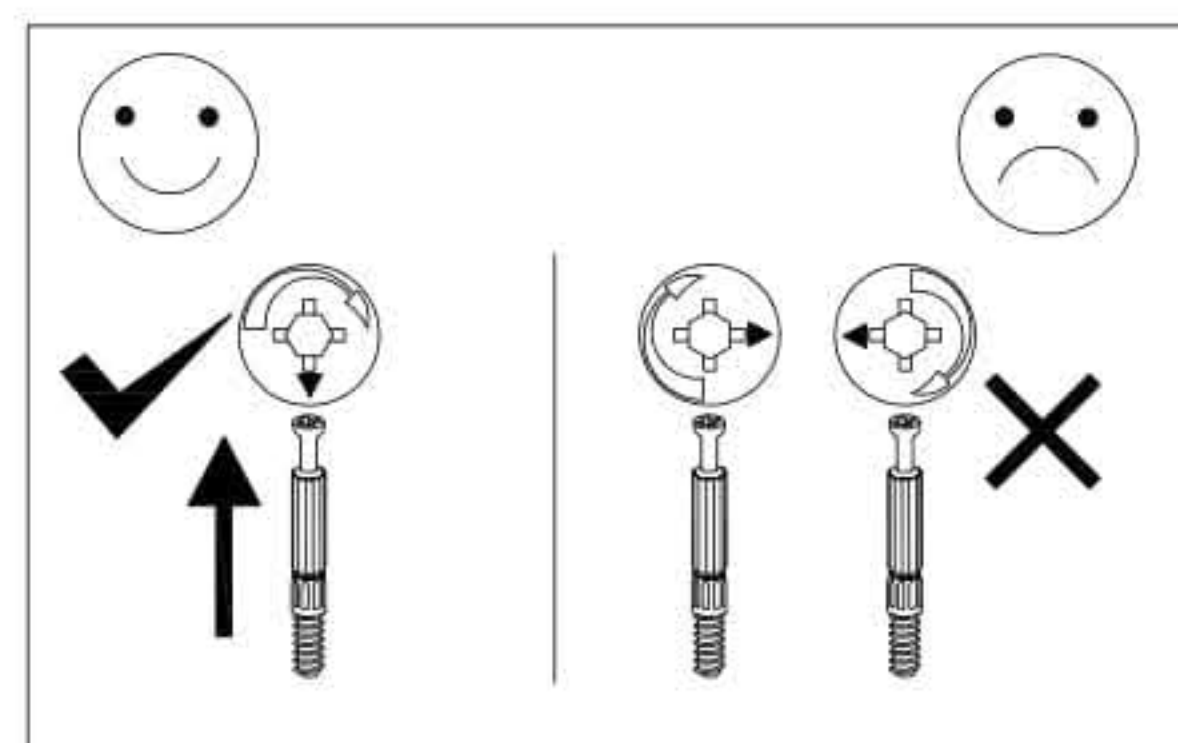
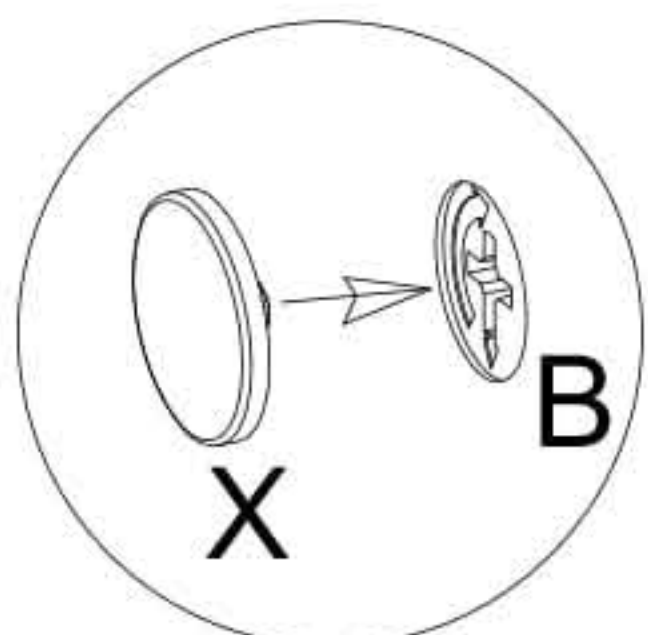
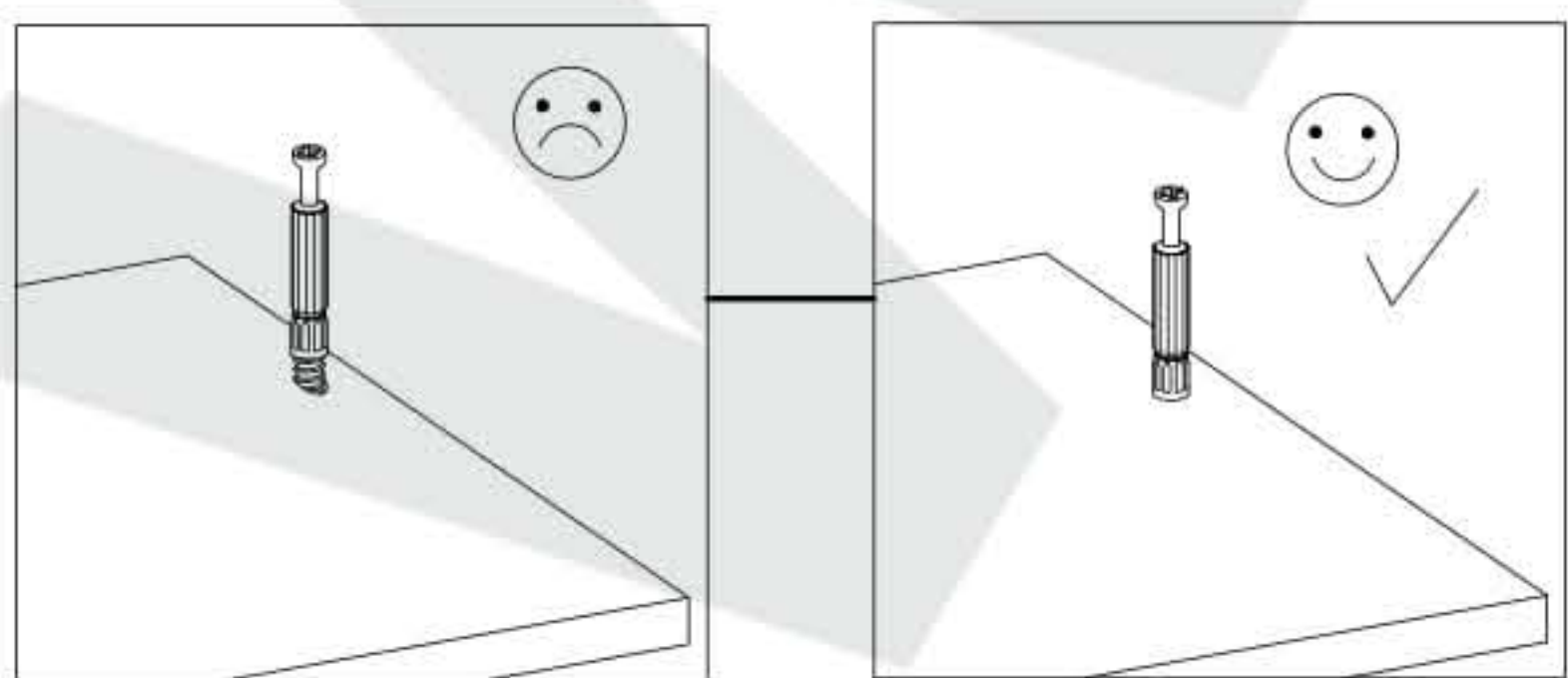
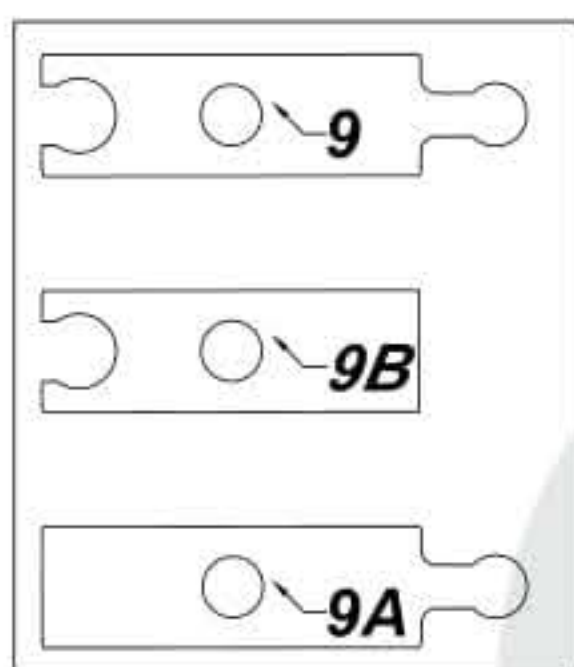
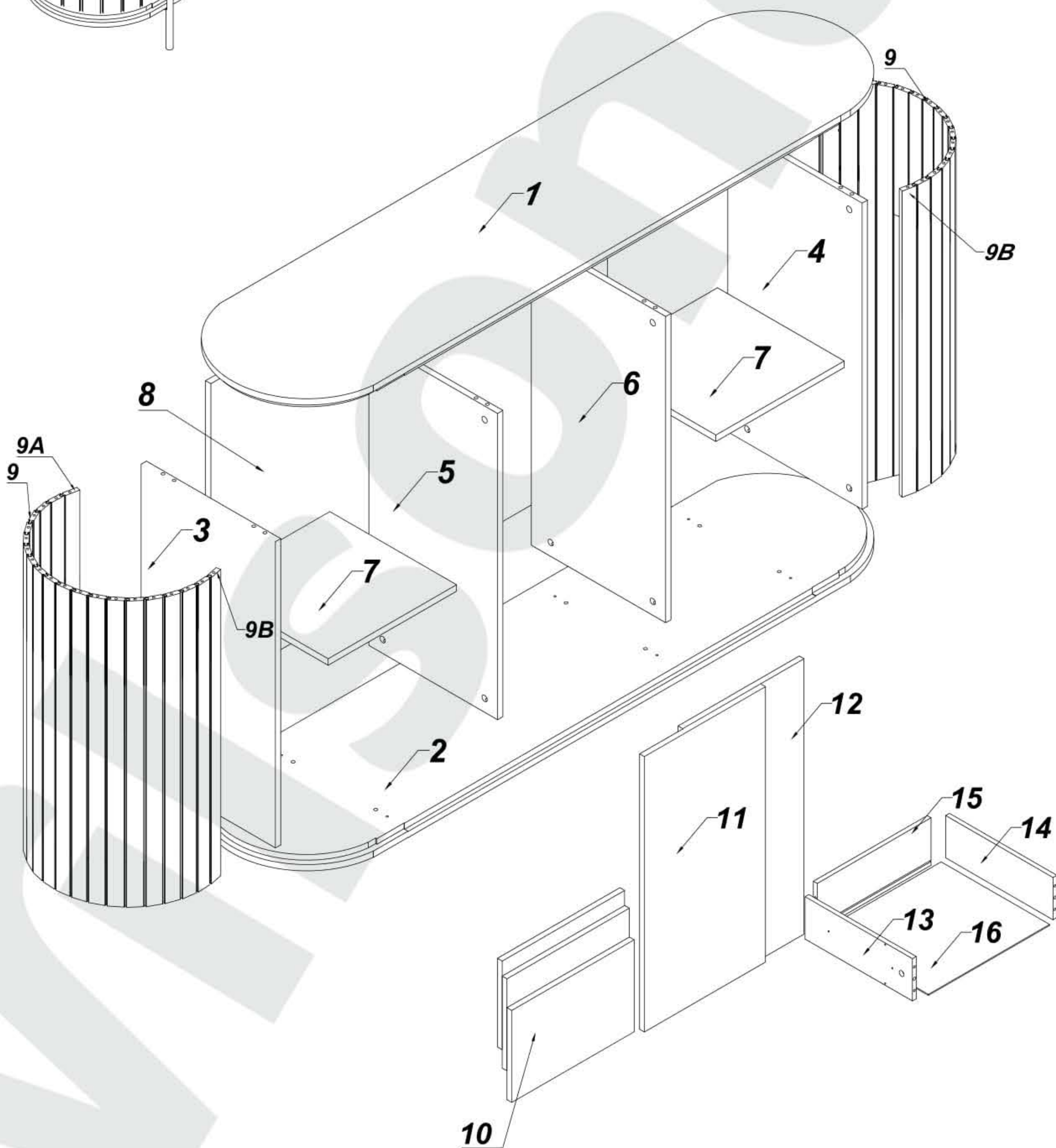

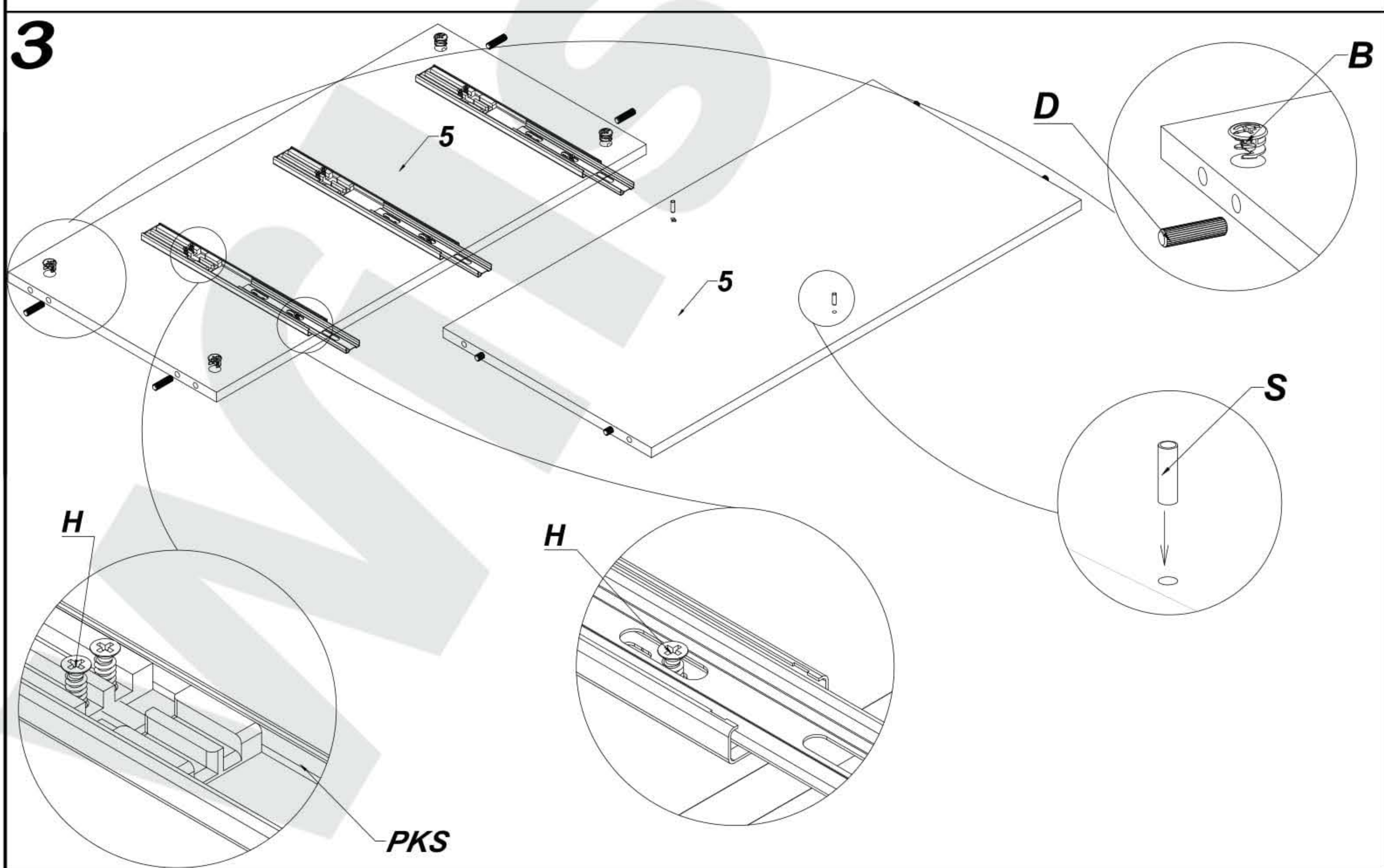
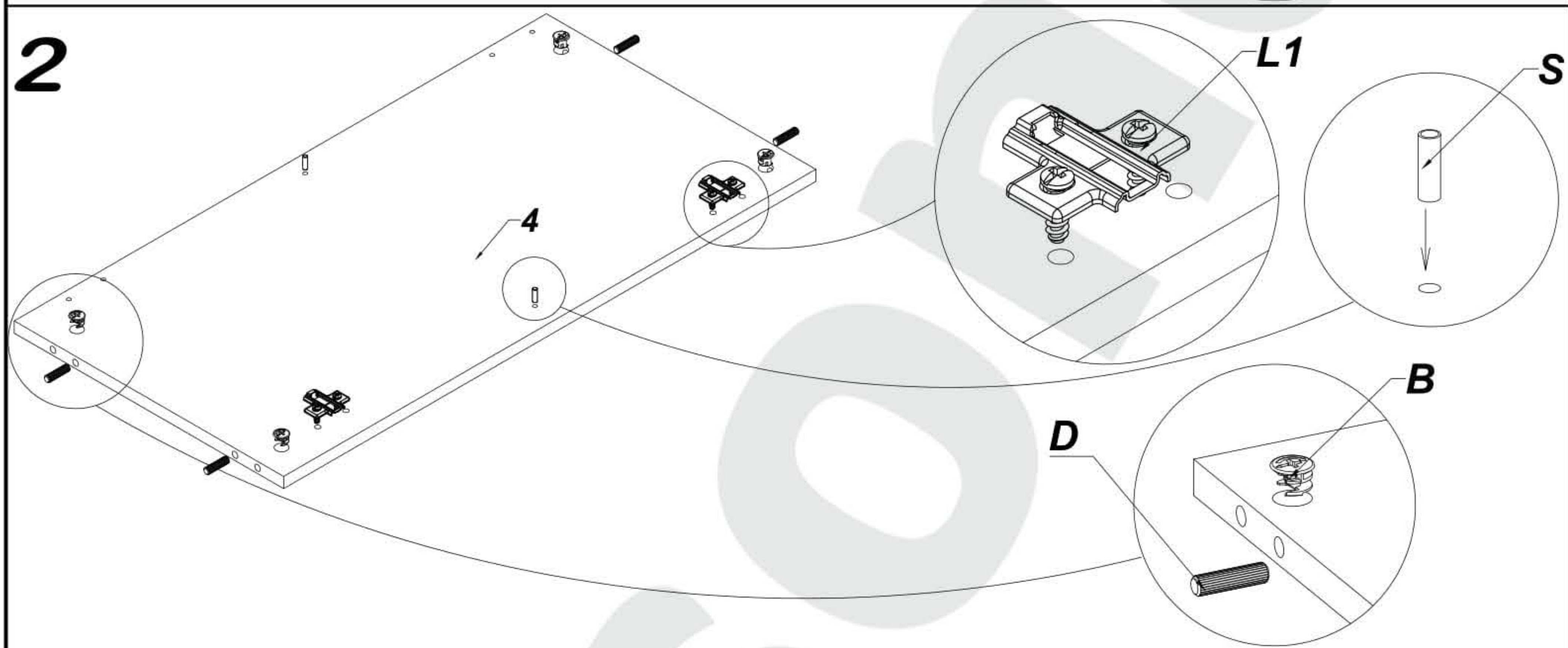
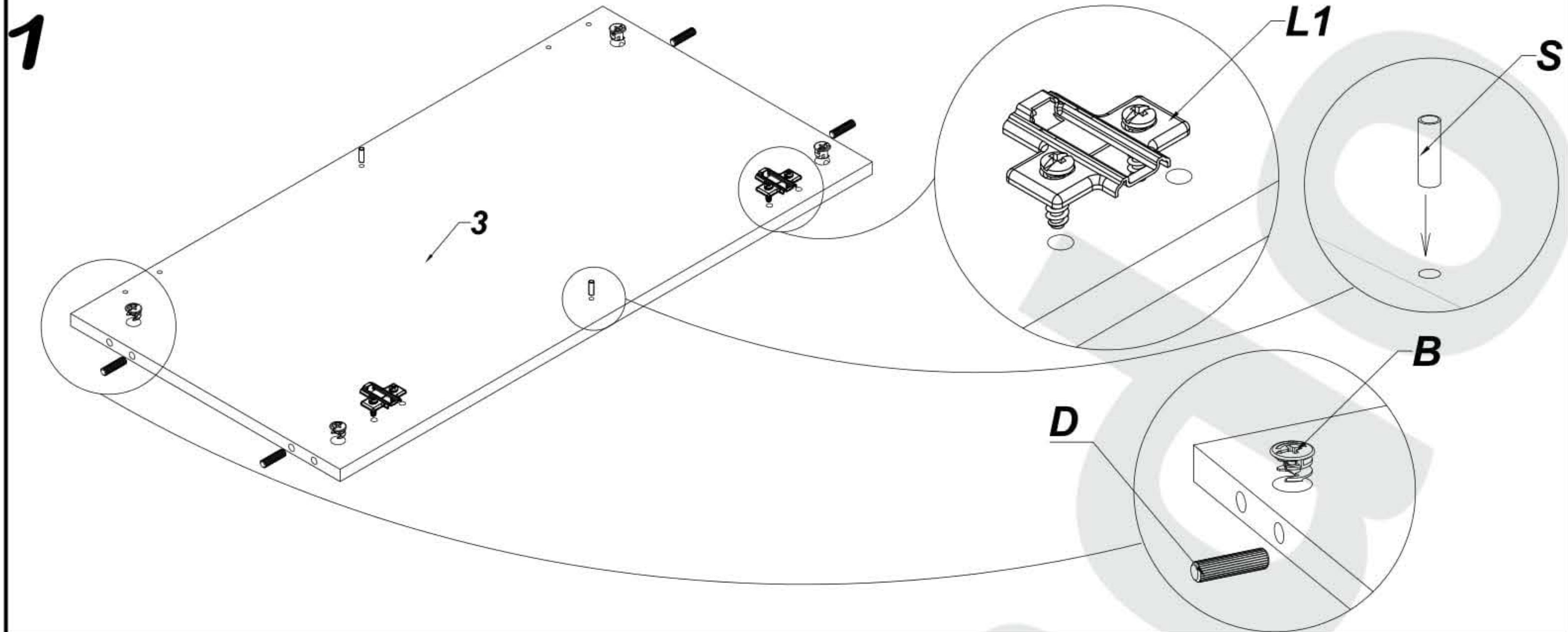

4

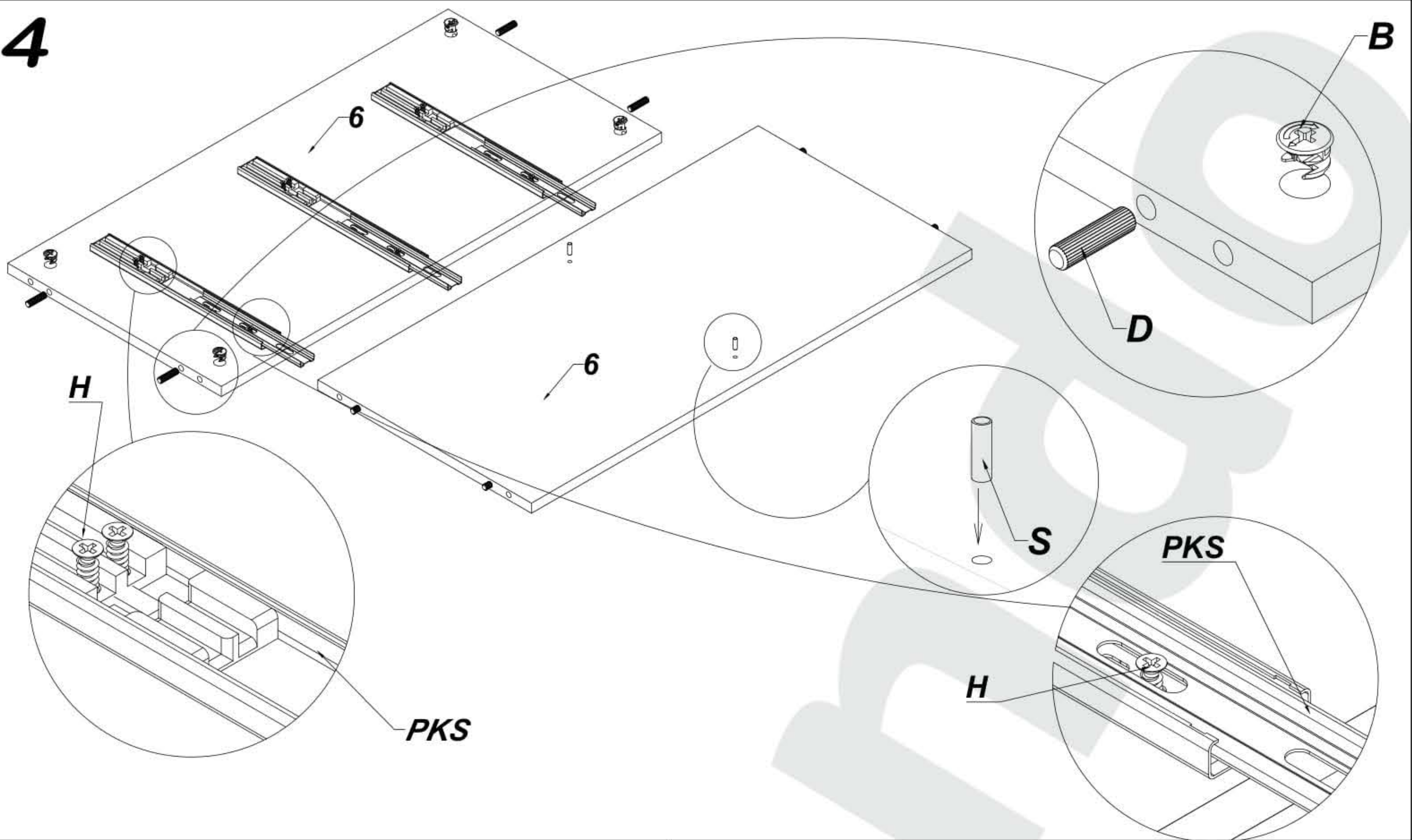

5

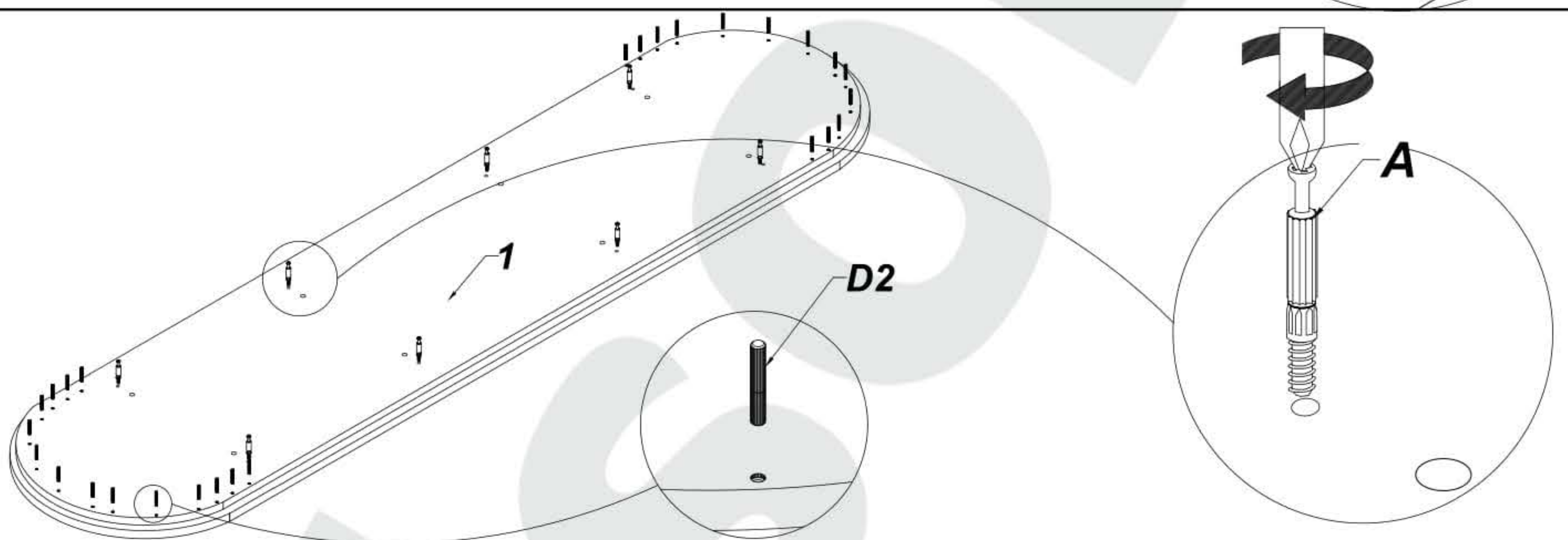

6

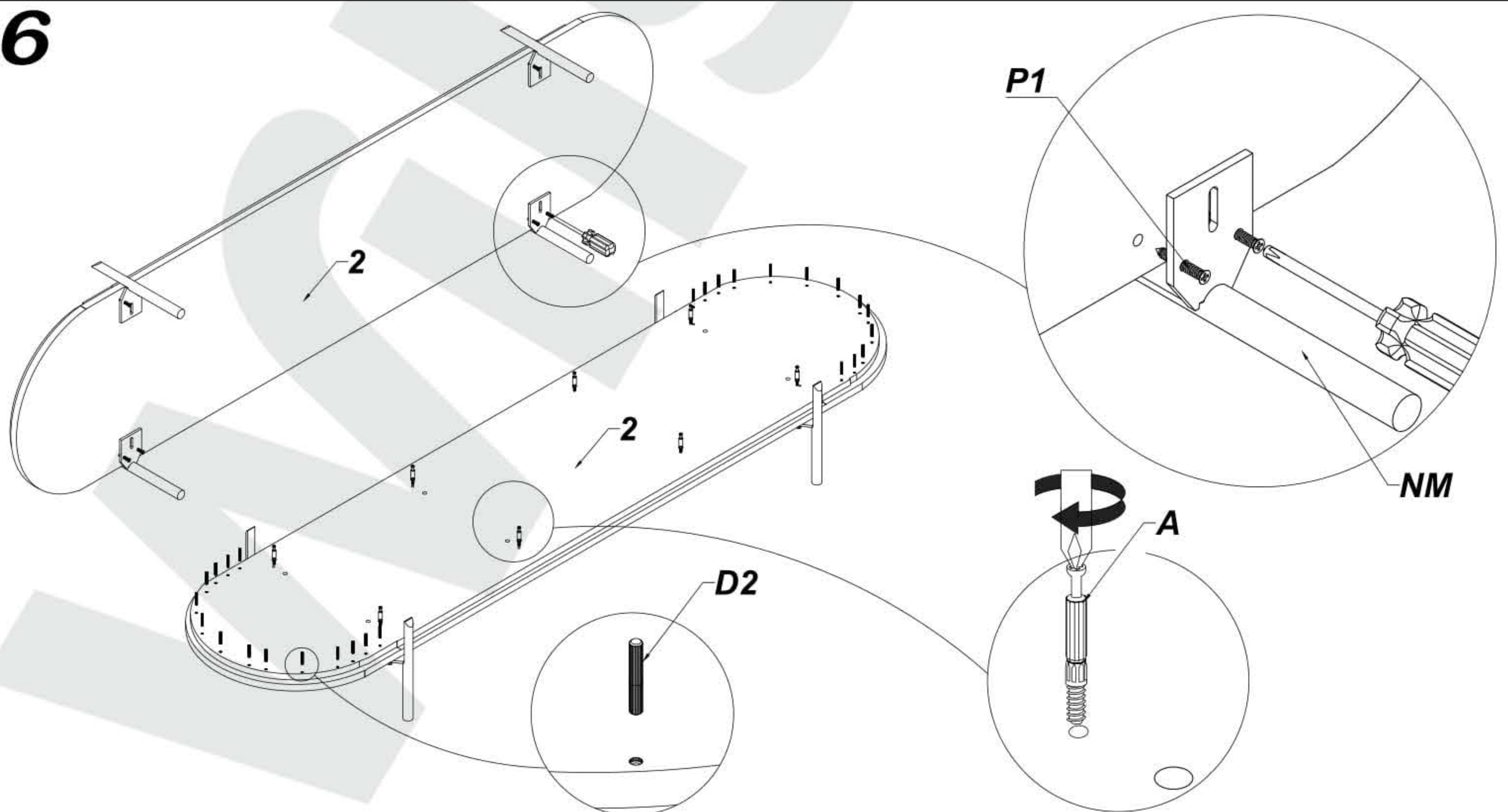

7

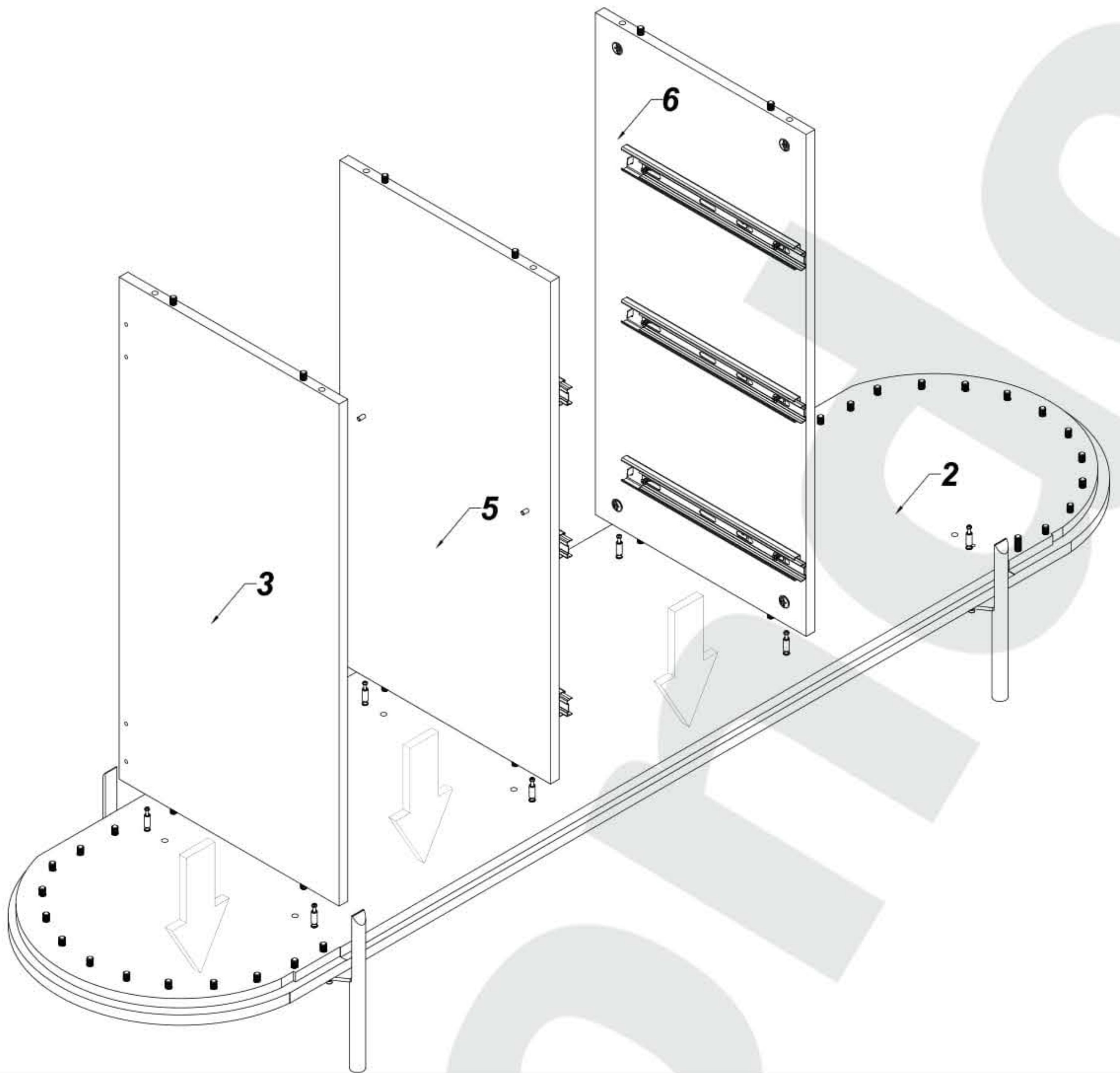

8

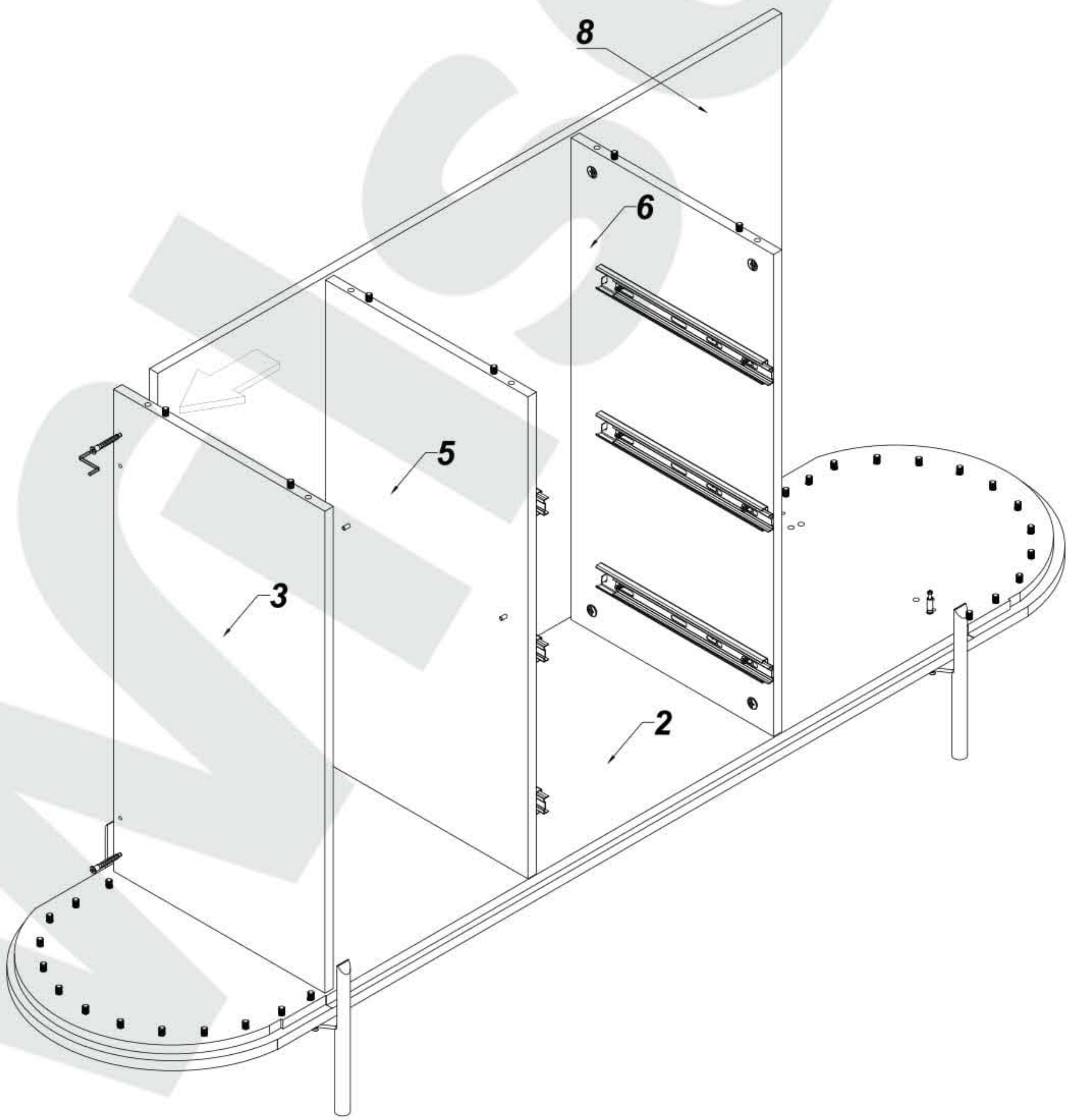

9

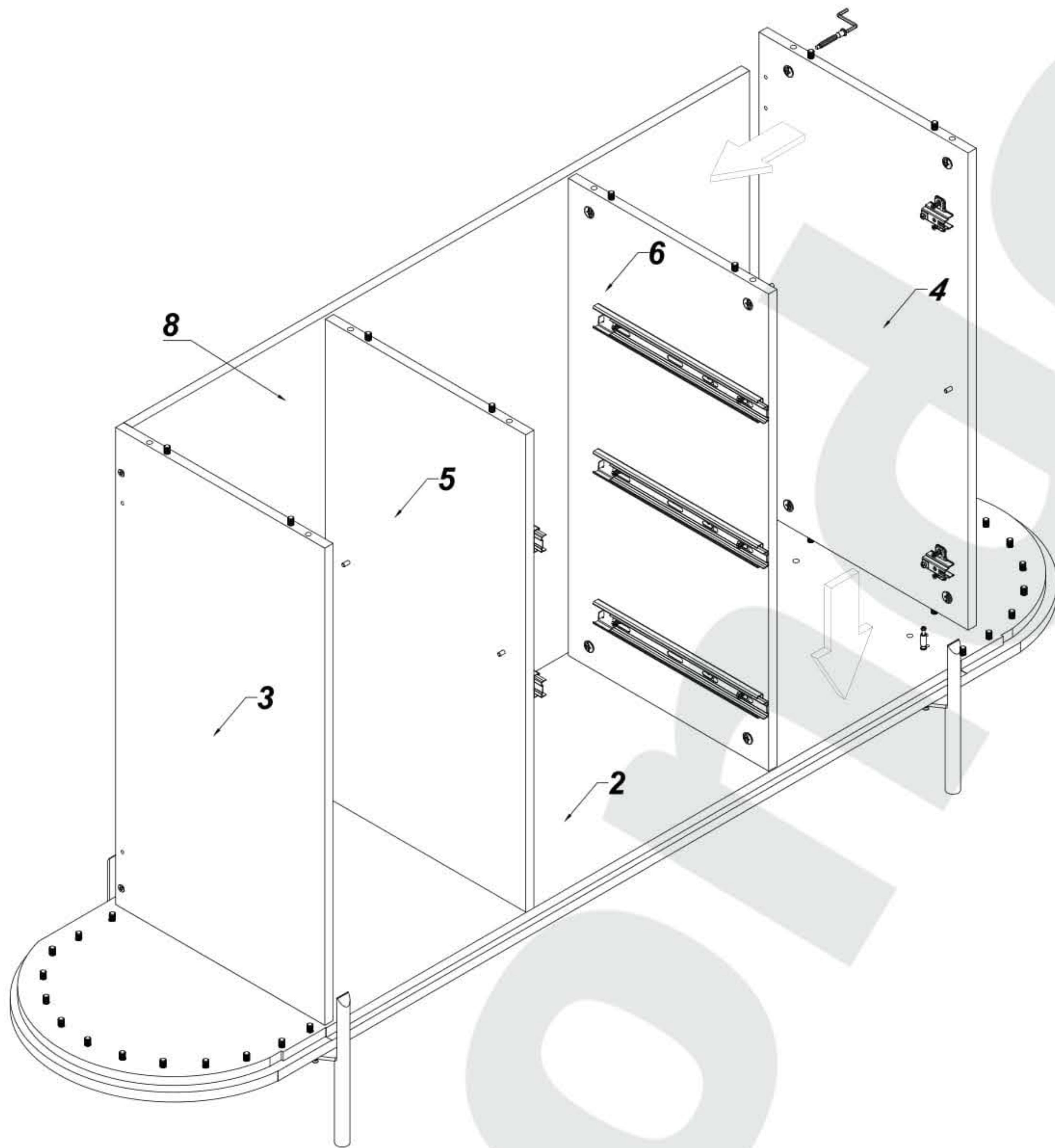

10

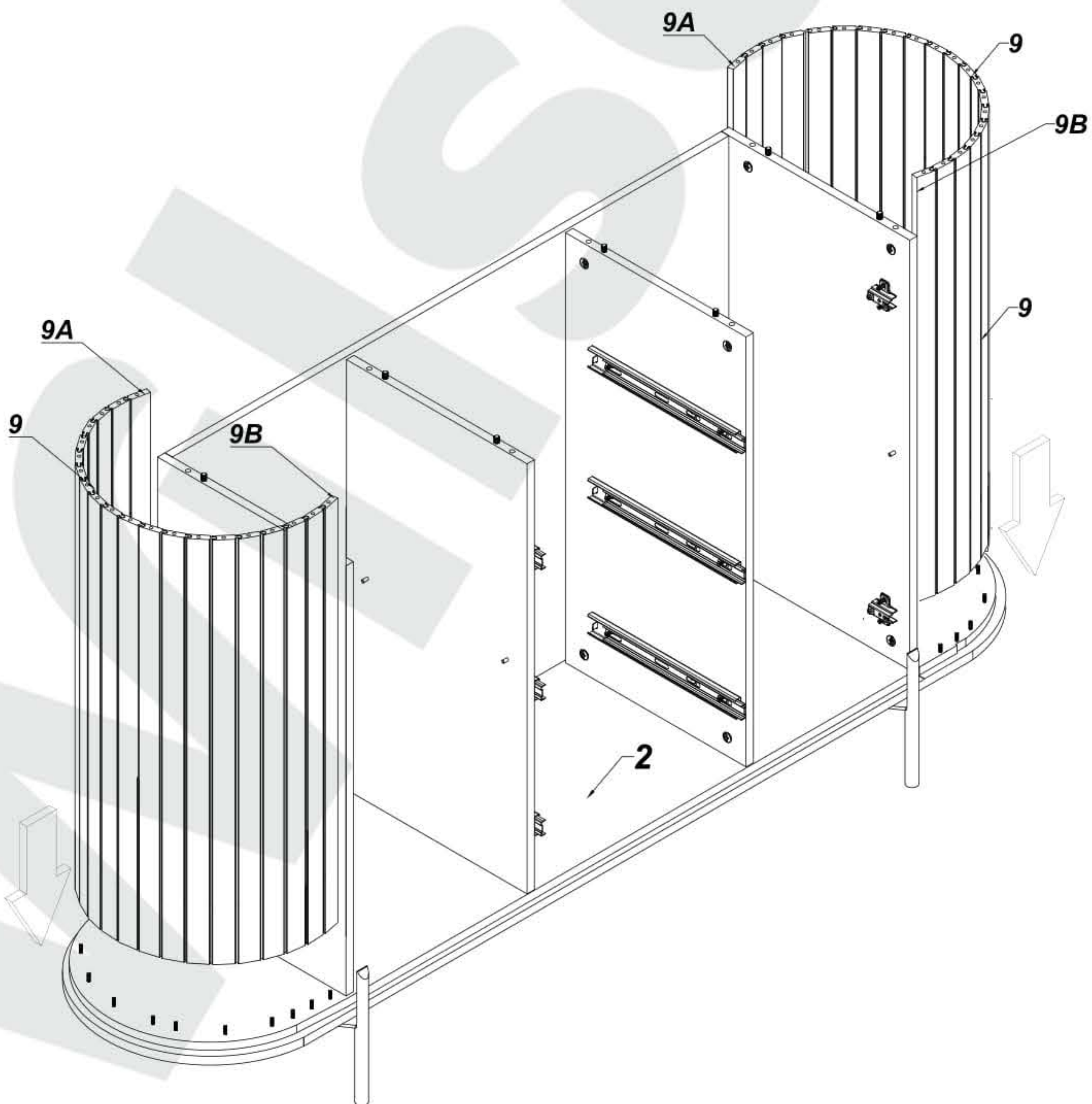

11

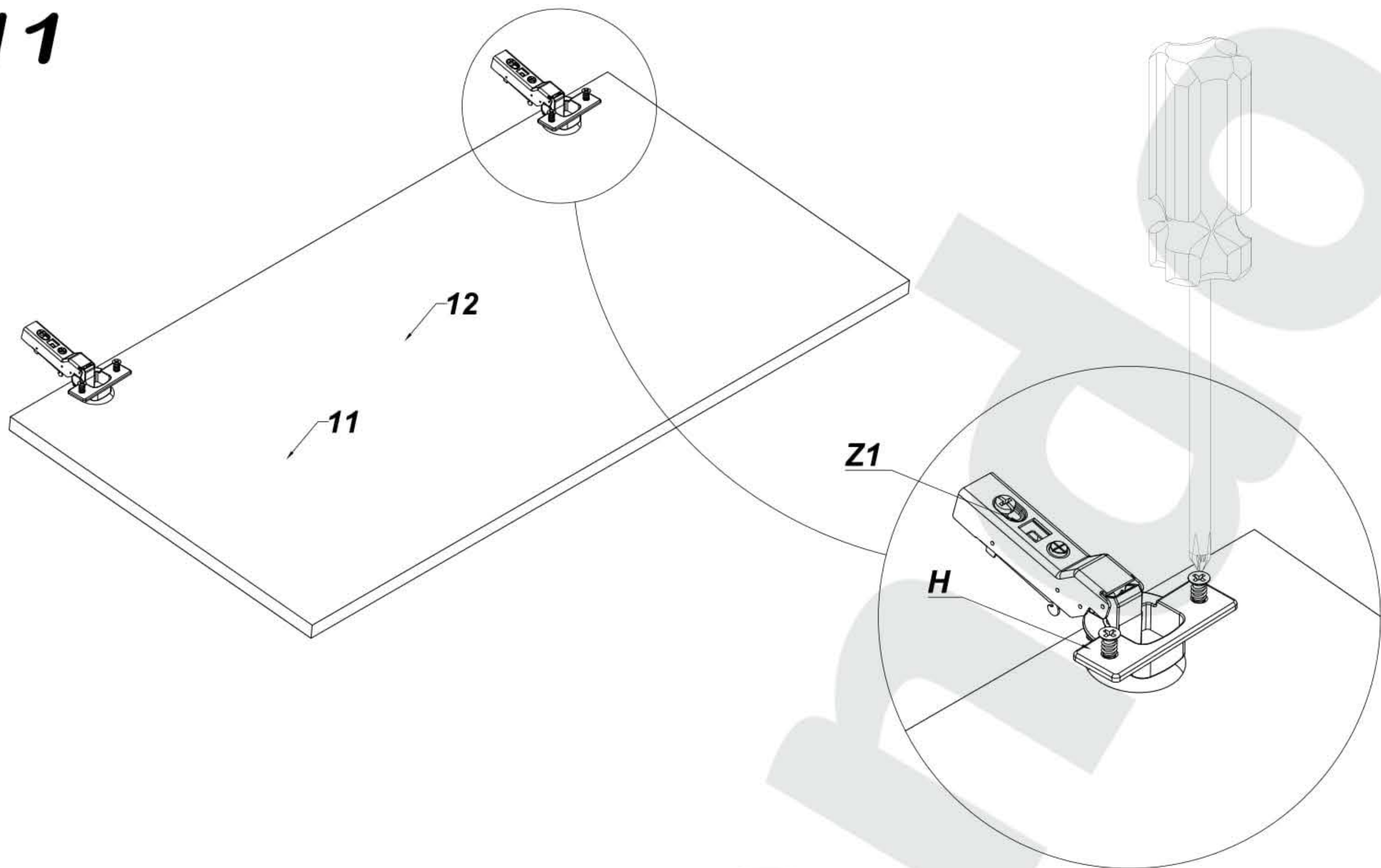

12

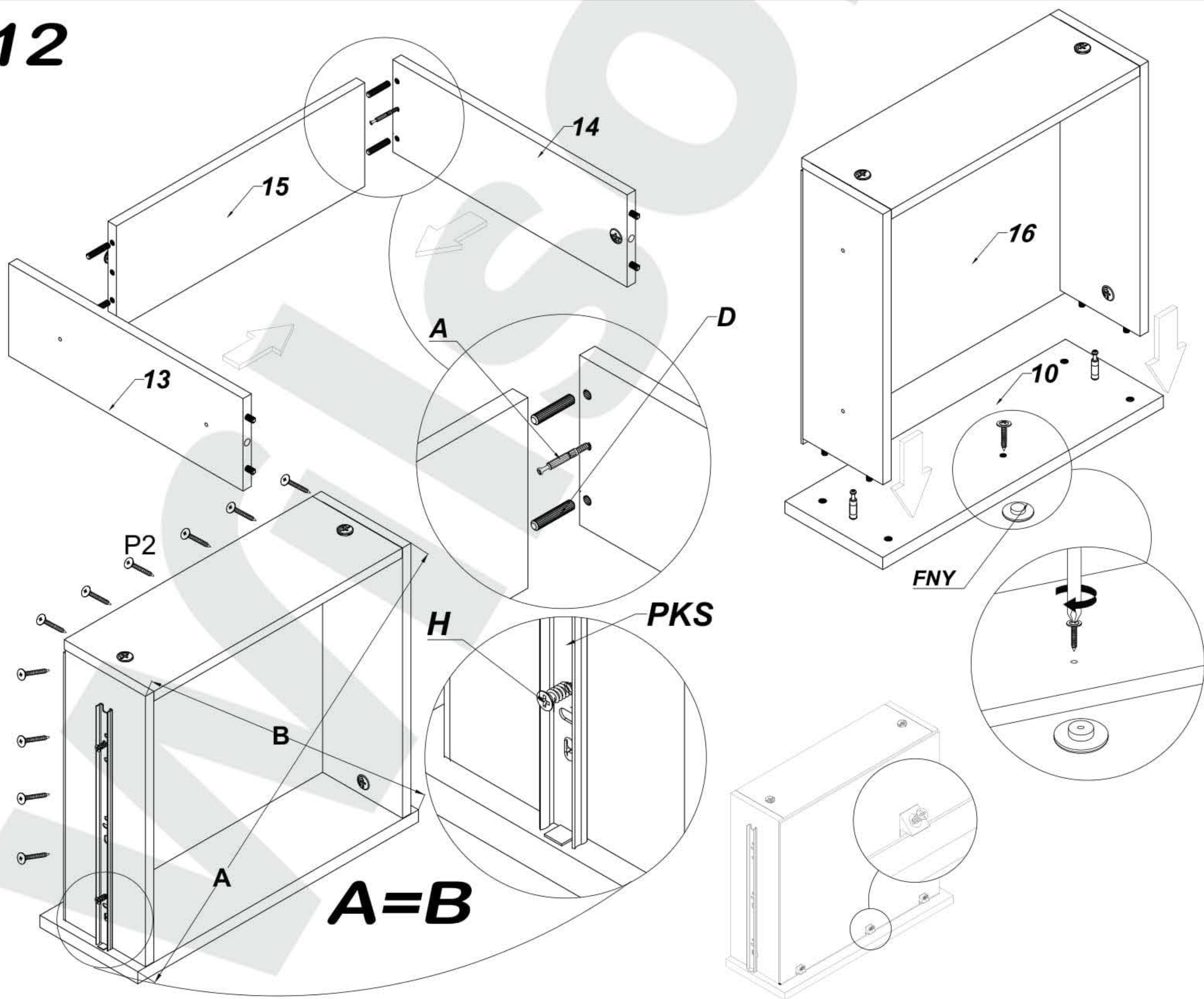

13

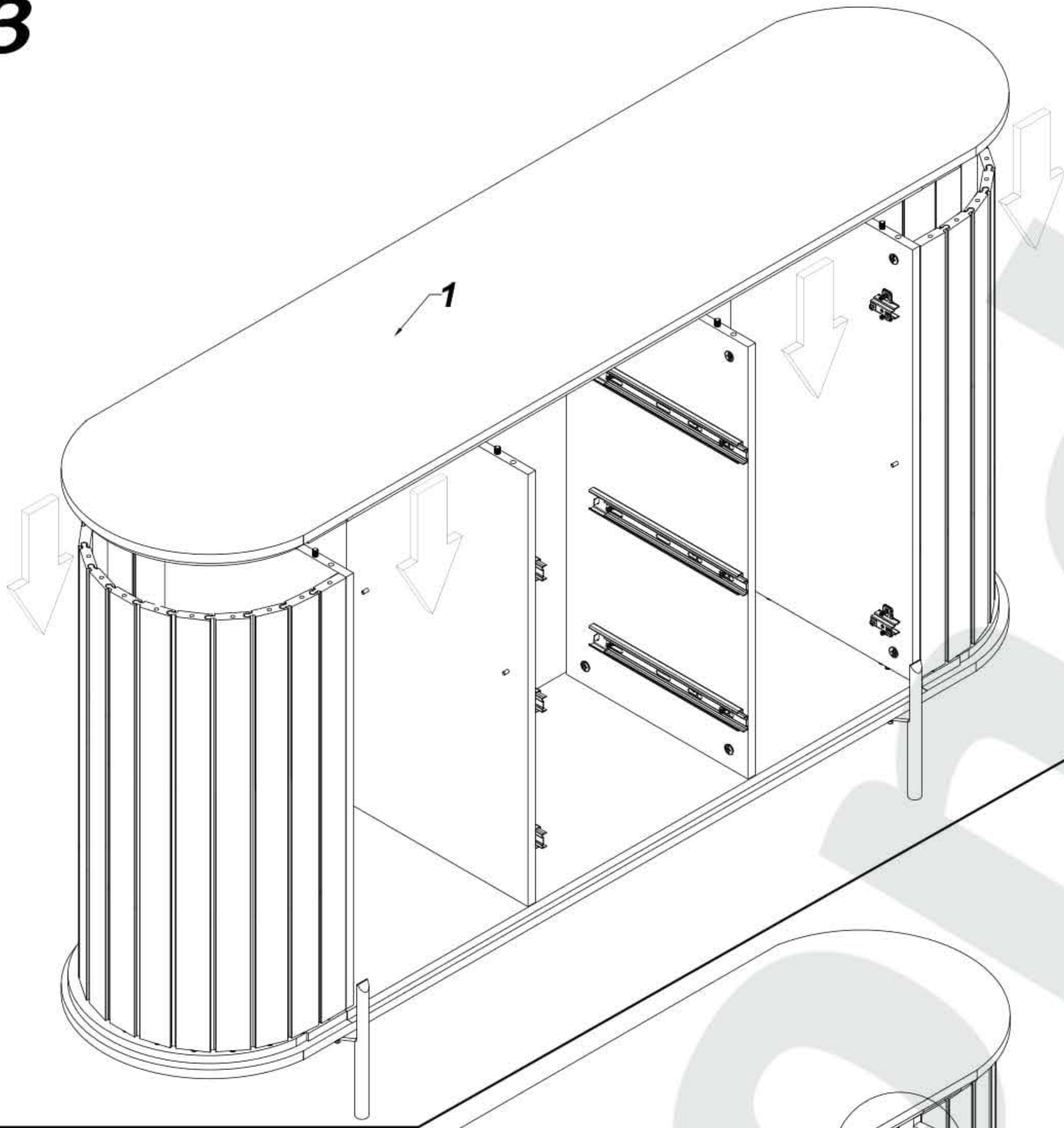

14

