

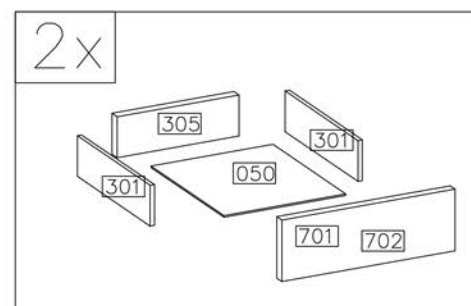

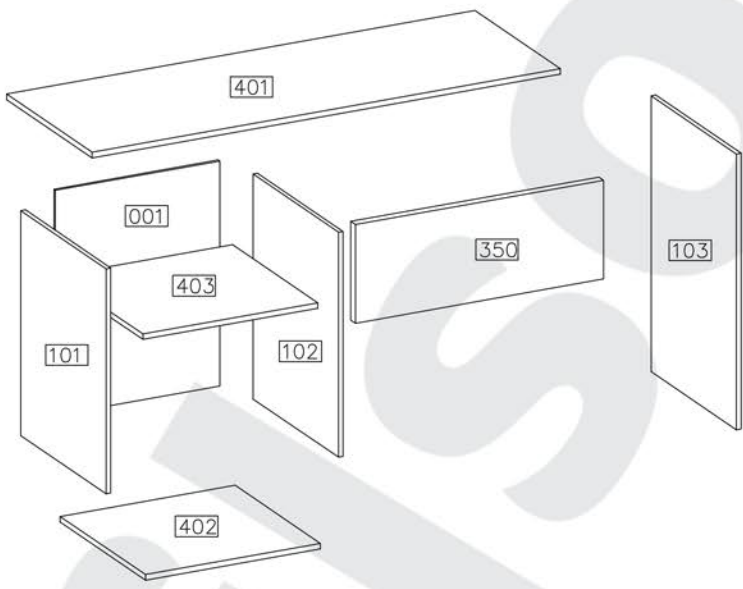

#	ART. NR	QUANTITY
1	401	1
2	402	1
3	403	1
4	101	1
5	102	1
6	103	1
7	350	1
8	701	1
9	702	1
10	301	4
11	305	2
12	050	2
13	001	1

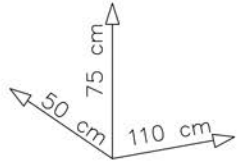
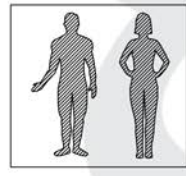
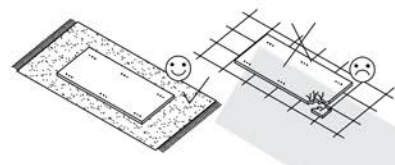

D1 26	C 26	E 26	A 41	S1 2	R2 2	P4 1	I4 2SET
F10 40	F4 4	B 8	E1 8	O 1	F1 2	P1 24	



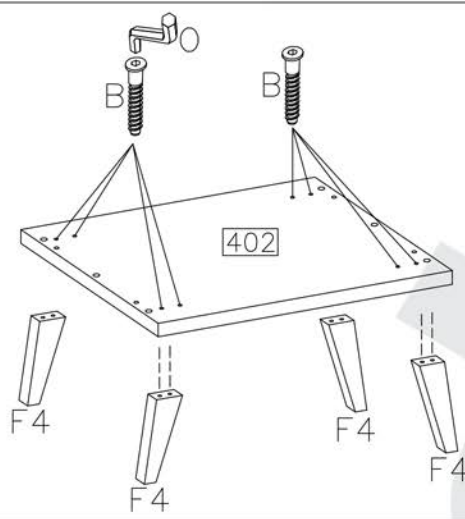

1

	
B	E1
8	8
	
F4	O
4	1



E10 B

2

	D1
10	
	A
6	
	C
4	

∅8x30mm ∅15/12mm

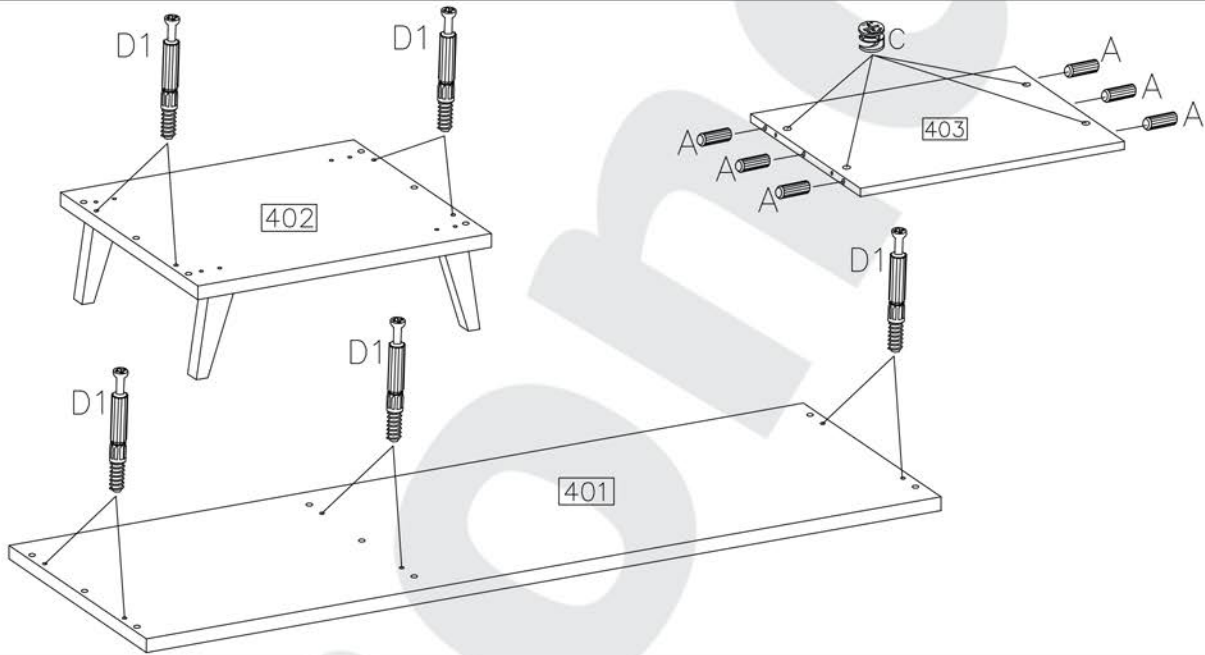
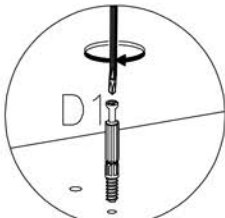

3

	A
12	
	C
8	
	D1
6	
	P1
12	



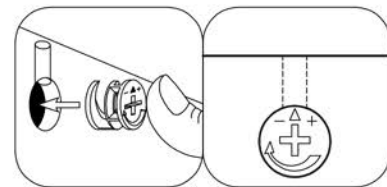
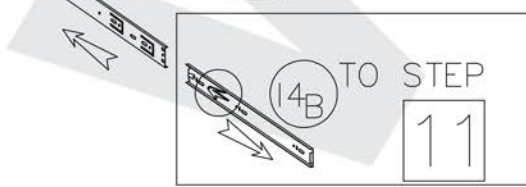
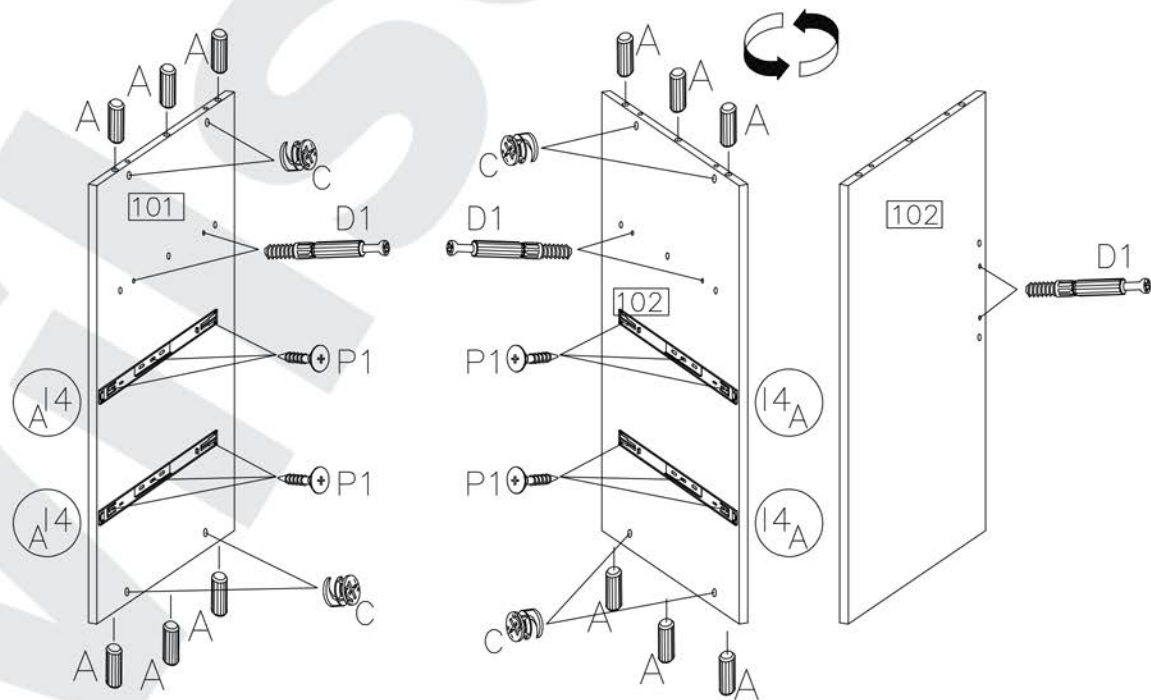

∅15/12mm ∅4.0x16mm

2SET

14



4

<p>∅8x30mm</p>  <p>A</p> <p>7</p>	 <p>D1</p> <p>2</p>
<p>∅15/12mm</p>  <p>C</p> <p>6</p>	 <p>F1</p> <p>2</p>

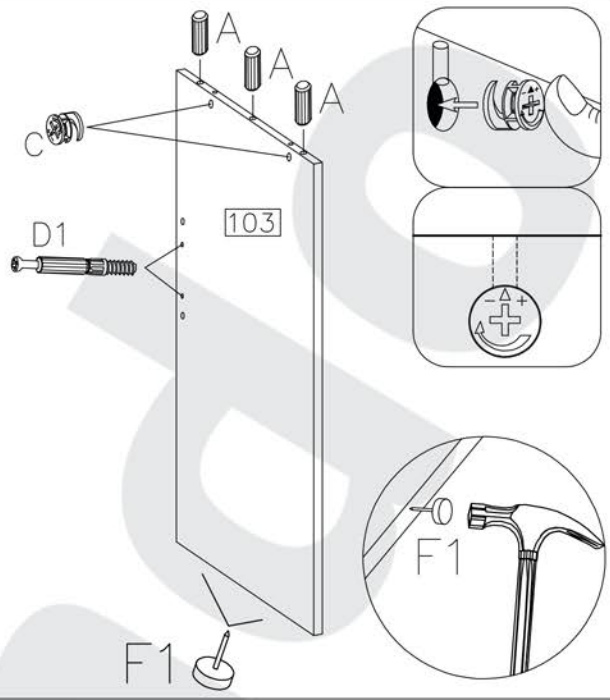
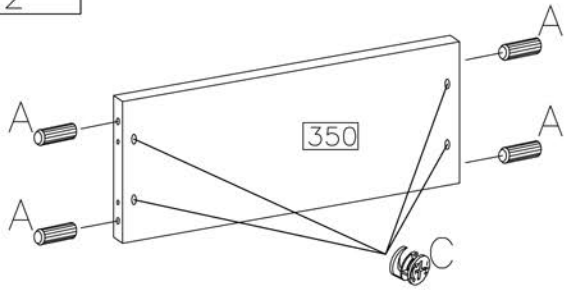

5

 <p>E</p> <p>8</p>
---

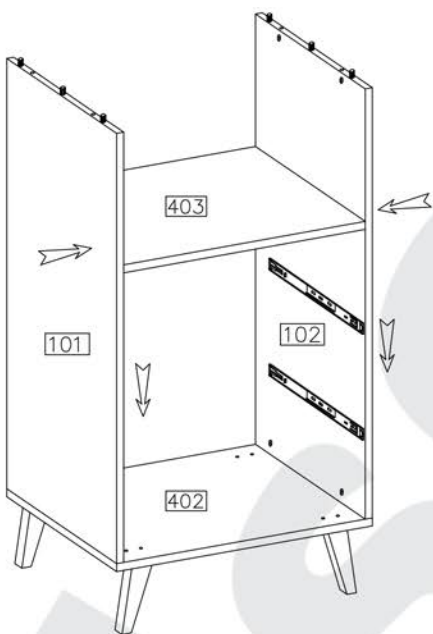

6

 <p>E</p> <p>2</p>
---

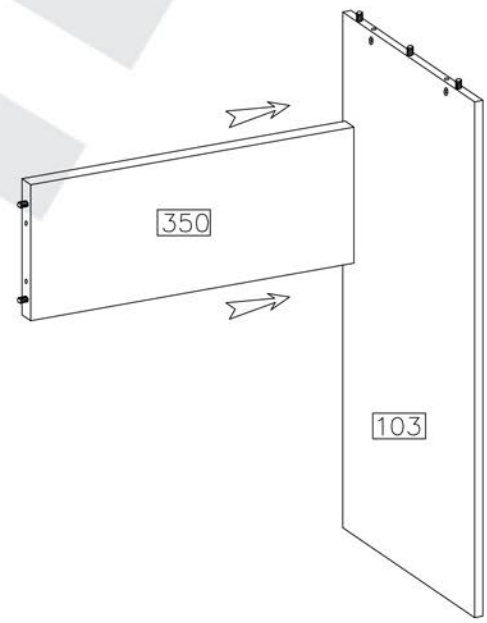

7

 <p>E</p> <p>8</p>
---

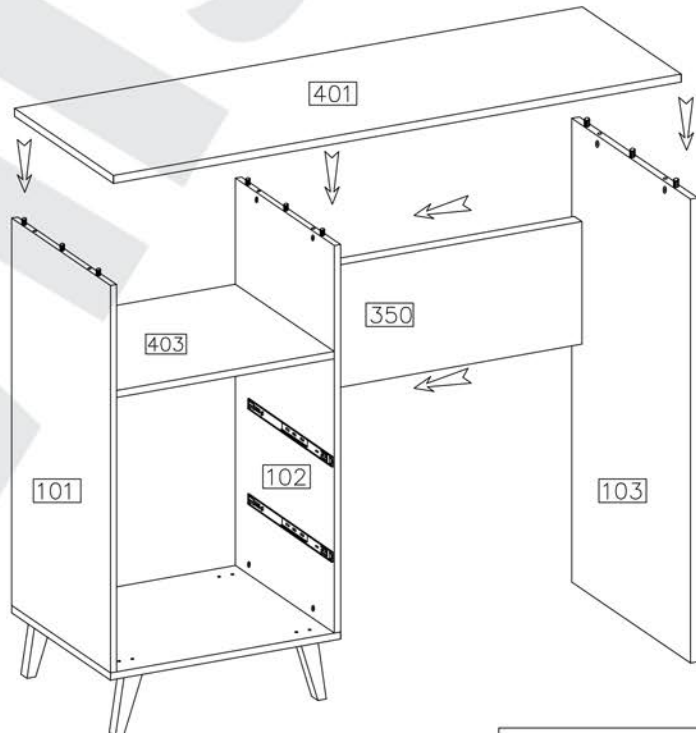

8

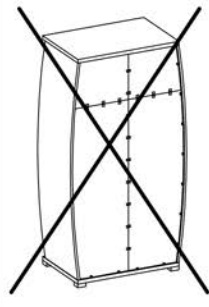
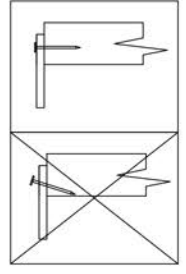
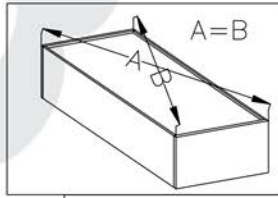
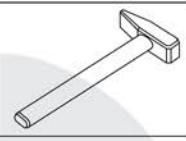
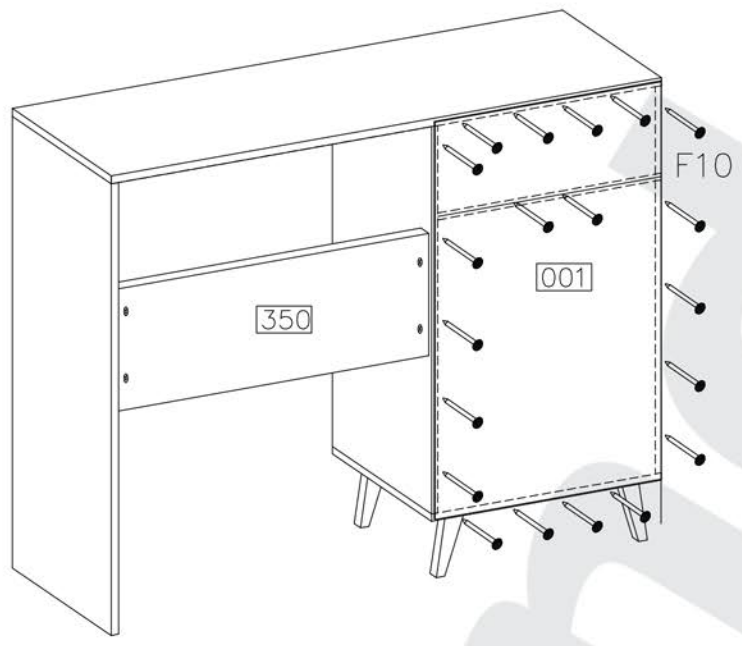

9

∅8x30mm



16



8

∅15/12mm



4

2x

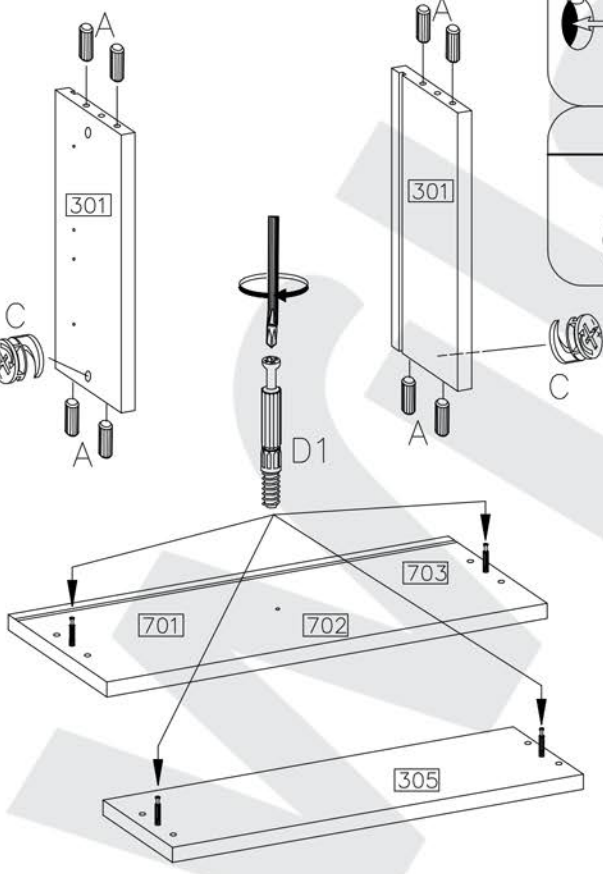
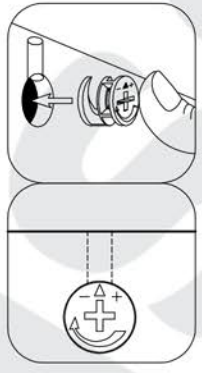

10



20

∅15/12mm





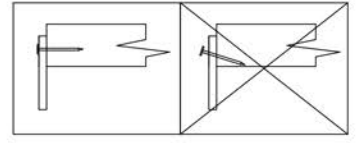
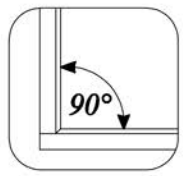
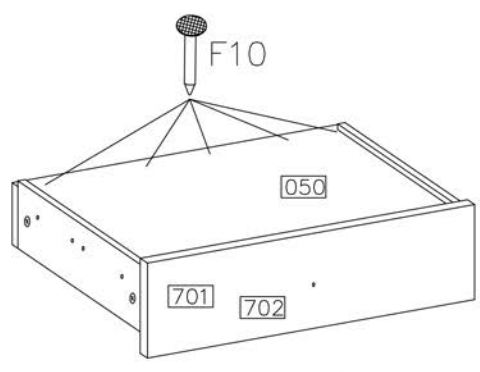
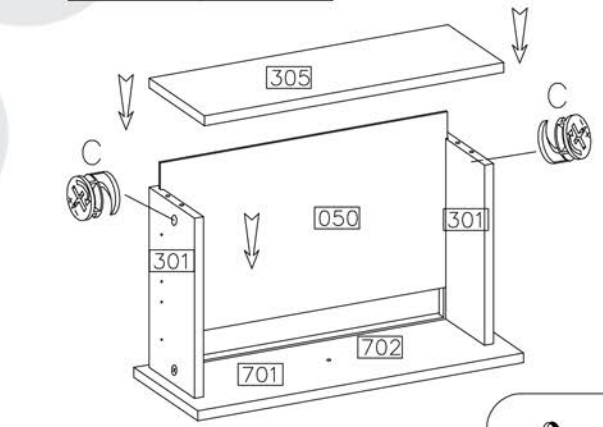
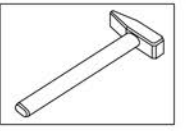

4

2x



11

	 S1	4.0x27mm  R2
	2	2
 E	 P1	 I4
8	12	2SET

2x

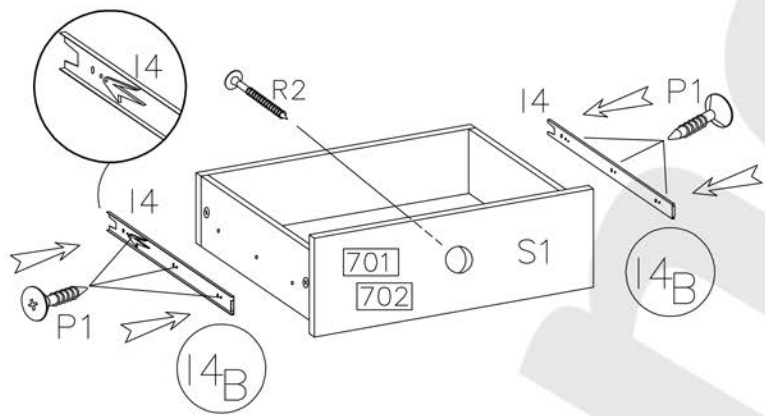
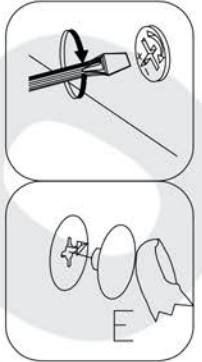

12

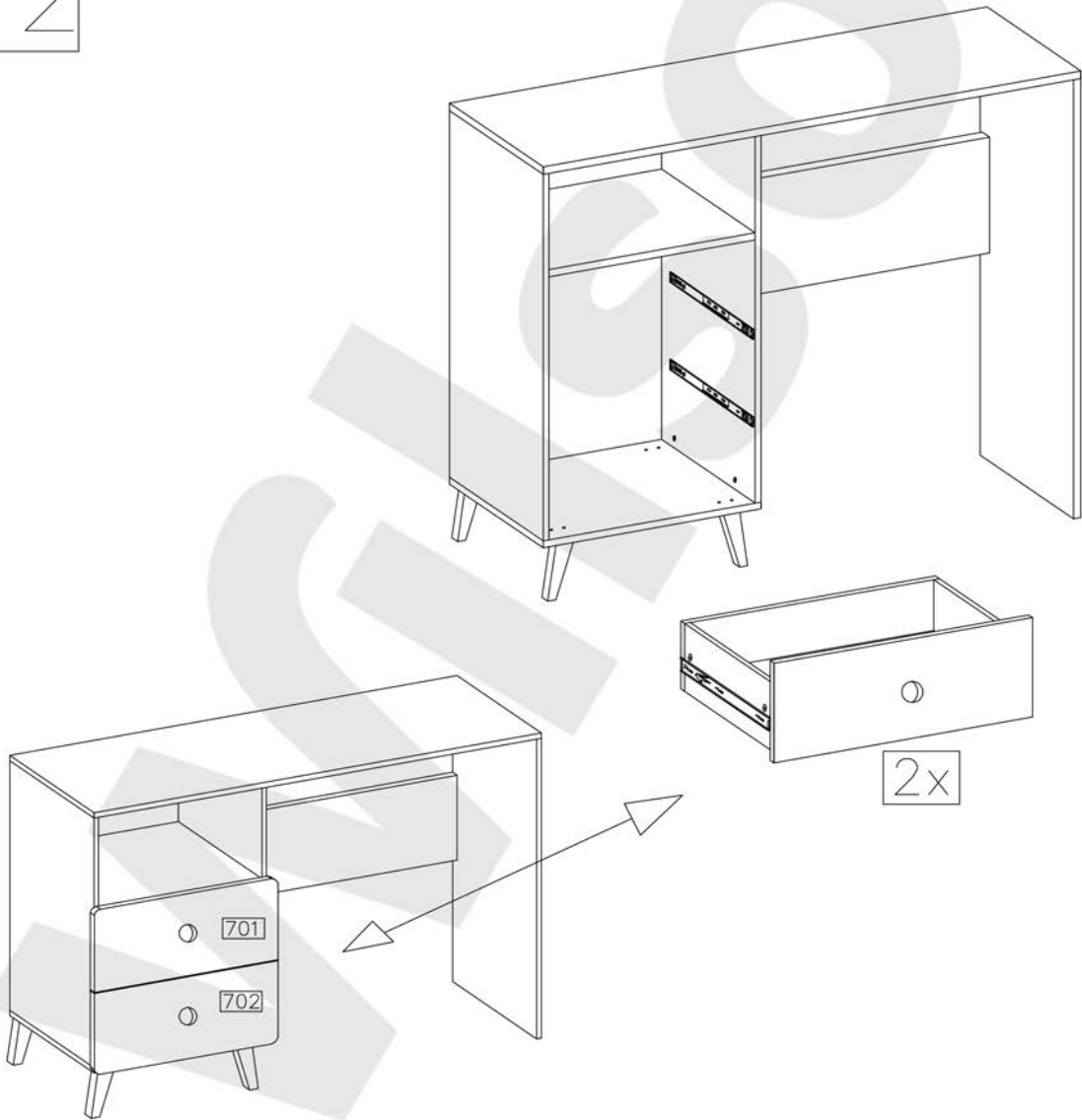

A

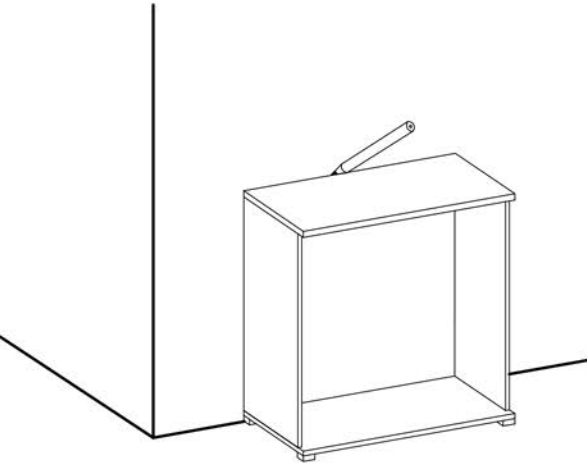

B

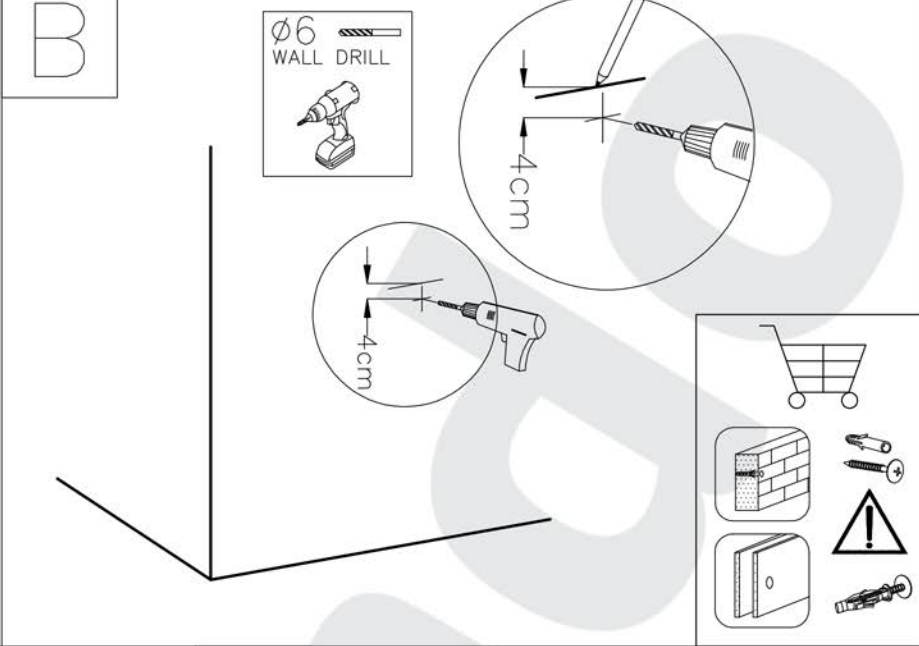

C

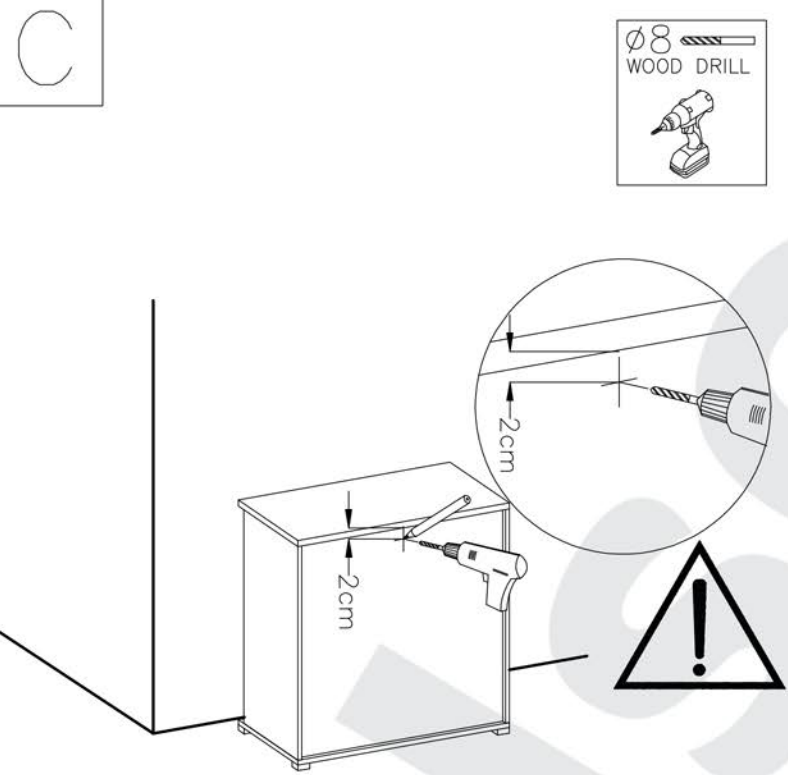

D

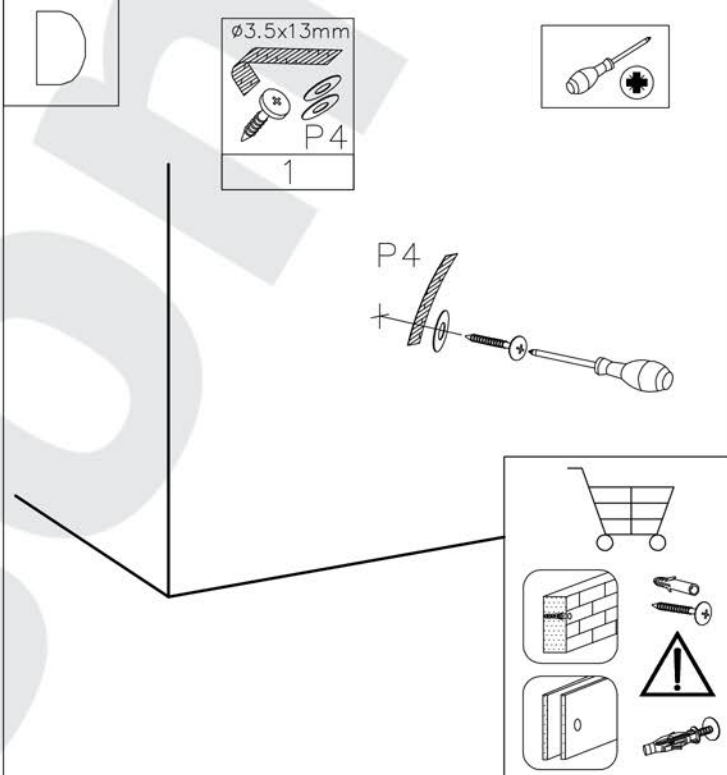

E

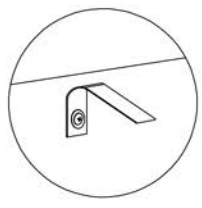
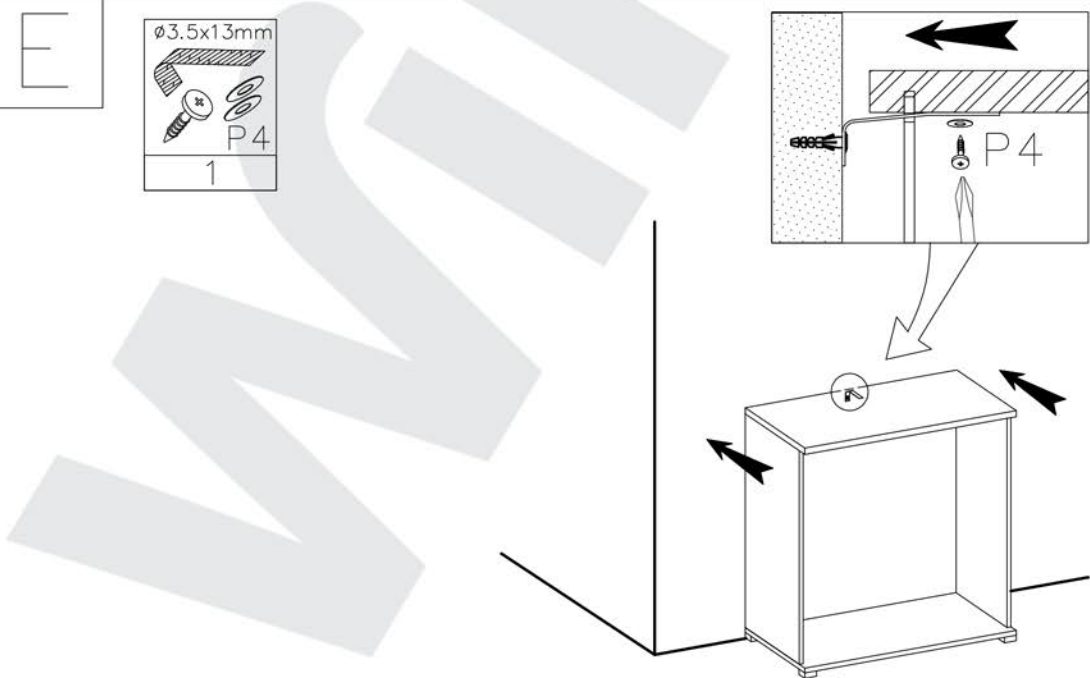

**PL-OSTRZEŻENIE PRZED WYWRÓCENIEM SIĘ**

Produkt musi być na stałe przymocowany do ściany dołączonymi uchwytemi, aby uniknąć śmiertelnego wypadku, gdy się przewróci. W pakiecie są tylko śruby pozwalające na przykręcenie uchwytów do produktu, które zapobiegają przewróceniu się produktu. Prosimy o skontaktowanie się ze specjalistycznym sklepem lub fachowcem w sprawie śrub lub kołków, które należy zastosować do danego typu ściany.

**GB-ANTI-TOPPLE WARNING!**

This product has to be permanently fixed to the wall with the bracket(s) included, to avoid fatal injury in case it topples over. The pack only contains screws for fastening the anti-topple bracket(s) itself to the product. Please contact your DIY or hardware store for advice on the correct type of screws/raw plugs for your type of wall.

**FR-AVERTISSEMENT ANTIBASCULEMENT**

Ce produit doit être fixé de manière permanente au mur à l'aide du/des support(s) inclus afin d'éviter des blessures mortelles en cas de basculement. L'emballage contient des vis pour attacher le(s) support(s) antibasculement au produit. Veuillez contacter votre magasin de bricolage ou votre quincaillerie pour obtenir des conseils sur le type de vis/chevilles adapté à votre mur.

**SK-VÝSTRAHA PRED PREVRÁTENÍM!**

Tento produkt musí byť natrvalo pripevnený k stene pomocou dodanej(-ých) konzoly (konzol), aby sa predišlo smrti ľnému úrazu v prípade, že sa prevráti. Balenie obsahuje iba skrutky, ktorými sa pripievajú k produktu samotné konzoly chrániace pred prevrátením. Kontaktujte miestnu predajňu pre domácich majstrov alebo železiarstvo, kde vám poradia ohľadom správneho typu skrutiek/príchytiiek pre váš typ steny.

**CZ-VAROVÁNÍ TÝKAJÍCÍ SE SKLOPENÍ!**

Tento výrobek musí být trvale připevněn na stěnu pomocí přiložených držáků, aby nedošlo ke smrtelnému zranění, kdyby se sklopil. Sada obsahuje pouze šroubky pro upevnění držáků zabraňujících sklopení k výrobku. Ohledně správného typu vrutů/hmoždinek pro daný typ stěny se obraťte na vhodný obchod nebo železářství.

**DE-ACHTUNG KIPPGEFAHR!**

Dieses Produkt muss mit der/den mitgelieferten Halterung(en) dauerhaft an der Wand befestigt werden, um tödliche Verletzungen im Falle eines Umkippens zu vermeiden. Die Verpackung enthält lediglich Schrauben zur Befestigung der Kippschutzhalterung(en) am Produkt. Für Informationen zur richtigen Schrauben-/Dübelart für Ihren Wandtyp wenden Sie sich bitte an Ihren Baumarkt.

**SRB-UPOZORENJE PRIJE KIPANJA!**

Proizvod mora biti trajno pričvršćen na zid priloženim zagradama kako bi se izbegle smrtne nesreće ako se prevrne. Postoje samo u paketu šrafovi koji omogućavaju da se ručke zavrnju na proizvodu, sprečavajući prevrtanje proizvoda. Molimo kontaktirajte specijaliste prodavnica ili specijalista u vezi sa vijcima ili čepovima koji će se koristiti za vrstu zida.

**HR-UPOZORENJE O ZAŠTITI OD PREVRTANJA!**

Proizvod mora biti trajno učvršćen na zid s pomoću isporučenih nosača kako bi se u slučaju prevrtanja proizvoda izbjegle smrtonosne ozljede. S proizvodom se isporučuju samo vijci za pričvršćivanje zaštitnih nosača na proizvod. Molimo Vas da od svog prodavača zatražite savjet o vrsti vijaka/tipli koje su najprikladnije za Vaš zid.

**HU-BORULÁS VESZÉLYE – FIGYELEM!**

A terméket fixen rögzíteni kell a falhoz a mellékelt tartóelem(ek) segítségével. Ellenkez ő esetben halálos sérülést okozhat, ha felborul. A csomag csak a borulásgátló tartóelem(ek)nek a termékhez való rögzítésére szolgáló csavarokat tartalmazza. Érdekl ődjön a DIY boltban vagy egy barkácsboltban, hogy milyen a megfelelő csavar, illetve tipli az adott faltípushoz.

**SL-OPOZORILO O ZAŠČITI PRED PREVRNITVIJO!**

Ta izdelek je treba s priloženimi nosilci trajno pritrditi na steno, da se izognete smrtnim poškodbam v primeru prevrnitve izdelka. Paket vsebuje le vijake za pritrditev zaščitnih nosilcev na izdelek. Strokovnjaka ali trgovino z opremo za dom povprašajte za nasvet glede pravičnega tipa vijakov/zidnih vložkov, ki so najbolj primerni za uporabo na vaši steni.

**NL-WAARSCHUWING KANTELBEVEILIGING!**

Dit product moet met de haak/haken permanent bevestigd worden aan de muur om verwondingen met dodelijke afloop te voorkomen indien deze omkantelt. De verpakking bevat enkel schroeven om de haken voor kantenbeveiliging op het product vast te maken. Contacteer uw doe-het-zelfzaak of bouwmarkt voor advies over het correcte type schroeven/rawlplugs voor uw soort muur.

