

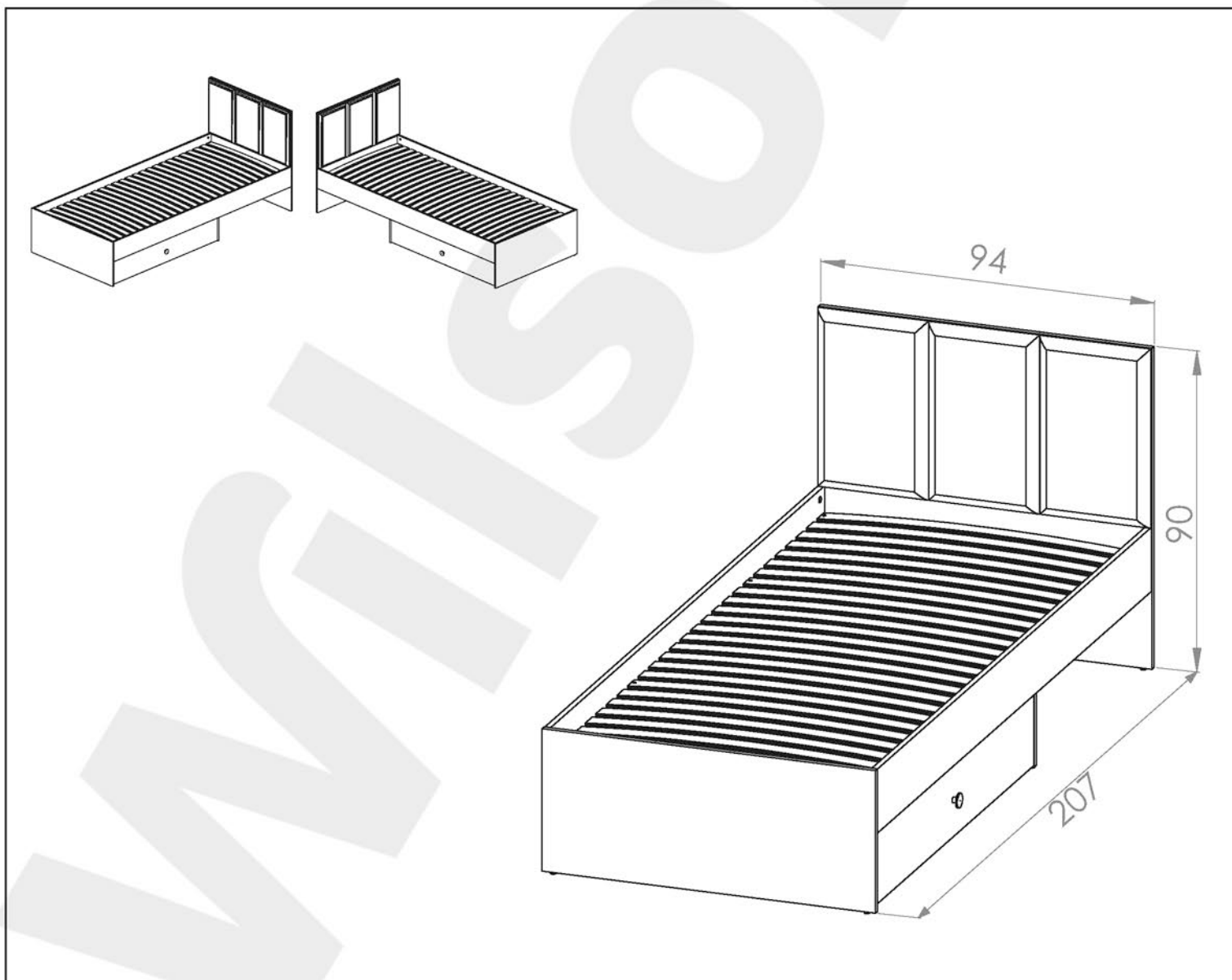

PL - Instrukcja montażu, bezpieczeństwo i utylizacji mebla. / BG - Инструкции за монтаж, безопасност и изхвърляне на мебелите. / CZ - Pokyny pro montáž, bezpečnost a likvidaci nábytku. / DE - Hinweise zur Montage, Sicherheit und Entsorgung der Möbel. / EN - Instructions for assembly, safety and disposal of the furniture. / ES - Instrucciones de montaje, seguridad y eliminación del mobiliario. / EST - Juhised mööbli kokkupanekuks, ohutuseks ja utiliseerimiseks. / FR - Instructions pour le montage, la sécurité et l'élimination des meubles. / HR - Upute za montažu, sigurnost i zbrinjavanje namještaja. / HU - A bútörök összeszerelésére, biztonságára és ártalmatlanítására vonatkozó utasítások. / I - Istruzioni per il montaggio, la sicurezza e lo smaltimento dei mobili. / LT - Baldų surinkimo, saugos ir utilizavimo instrukcijos. / LV - Norādījumi par mēbeļu montāžu, drošību un utilizāciju. / NL - Instructies voor montage, veiligheid en afvoer van het meubilair. / P - Instruções de montagem, segurança e descarte dos móveis. / RO - Instrucțiuni pentru asamblarea, siguranța și eliminarea mobilierului. / RU - Инструкция по сборке, безопасности и утилизации мебели. / SE - Instruktioner för montering, säkerhet och kassering av möblerna. / SK - Návod na montáž, bezpečnosť a likvidáciu nábytku. / SLO - Navodila za montažo, varnost in odlaganje pohištva. / SRB - Упутство за монтажу, безбедност и одлагање намештаја. / TR - Mobilyalann montajı, güvenliği ve imhasına ilişkin talimatlar. / UKR - Інструкція з монтажу, безпеки та утилізації меблів.

PL - Przed rozpoczęciem zapoznać się z instrukcją montażu / BG - Преди да започнете се отнасят към инструкциите за инсталиране / CZ - Před zahájením naleznete v montážním návodu / DE - Vor die montage, bitte beiliegende anweisungen folgen / EN - Before starting, refer to the assembling advice in annex / ES - Antes de comenzar referirse a las instrucciones de instalación / EST - Enne käivitamist vaadake paigaldusjuhiseid / FR - Avant de commencer, se reporter aux conseils de montage en annexe / HR - Prije početka pogledajte upute za instalaciju / HU - Megkezdése előtt olvassa el a telepítési utasításokat / I - Avanti di cominciare, riportate agli consigli di montaggio / LT - Prieš pradedant kreiptis į montavimo instrukcija / LV - Pirms sākt montāžu, iepazīties ar instrukciju / NL - Voordat u begint Zie de installatie-instructies / P - Antes de começar a consultar as instruções de instalação / RO - Înainte de a începe să consultați instrucțiunile de instalare / RU - Перед началом обратитесь к инструкции по установке / S - Innan du börjar se Installationsanvisningen / SK - Pred začatím nájdete v montážnom návode / SLO - Pred začetkom glejte navodila za nameštitev / SRB - Пре почетка погледајте упутства за инсталацију / TR - Kurulumla basl madan once, montaj talimatnamesini sirasiyla takip edin. / UKR - Перед початком зверніться до інструкції з установки /

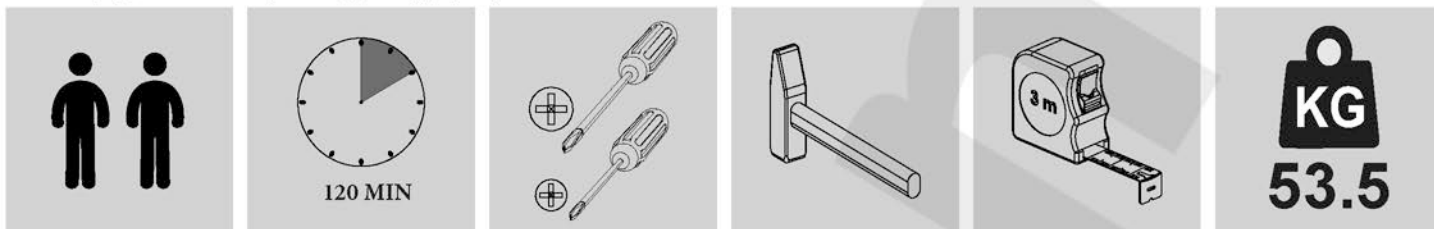

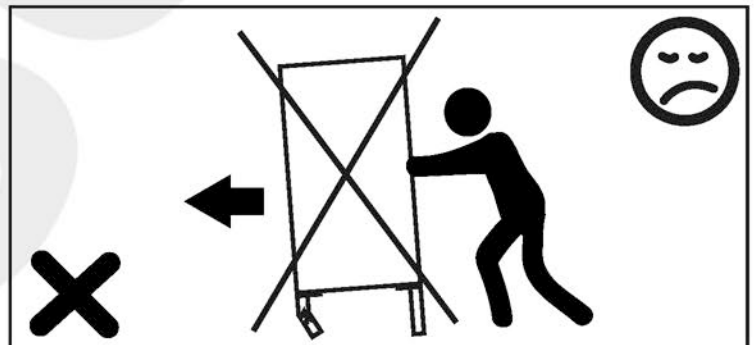
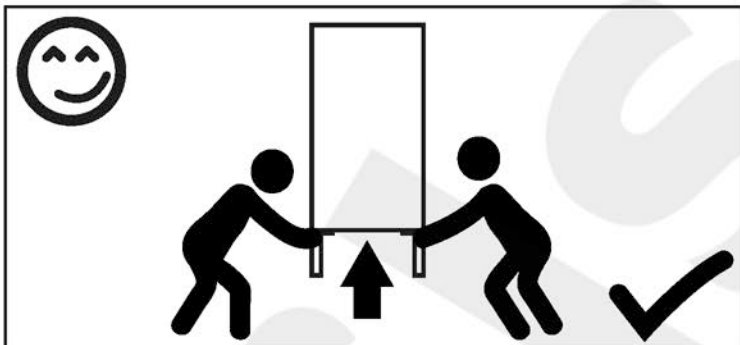
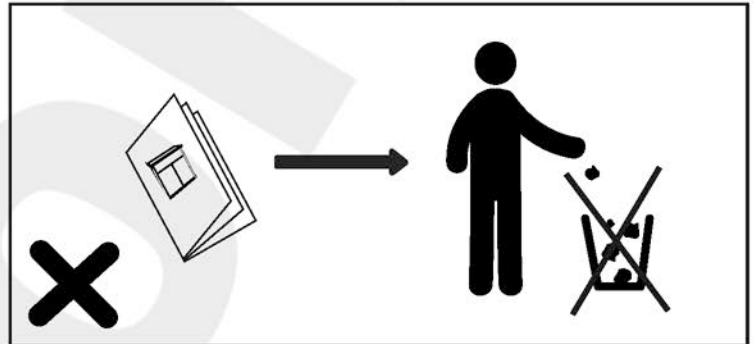
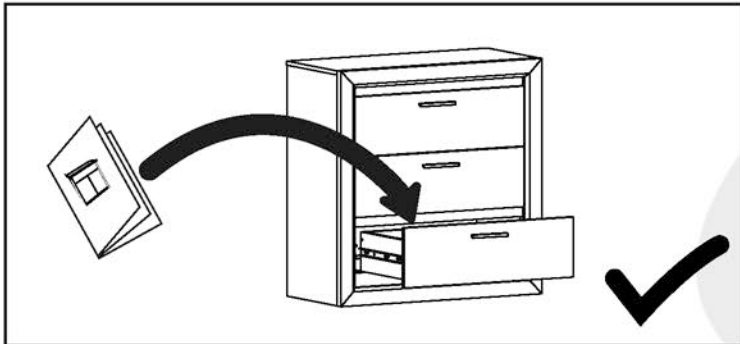
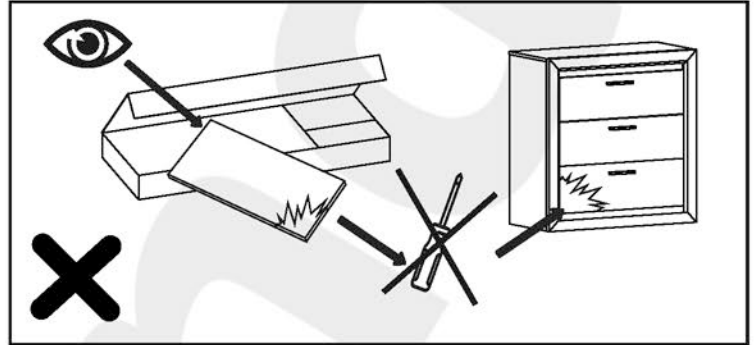
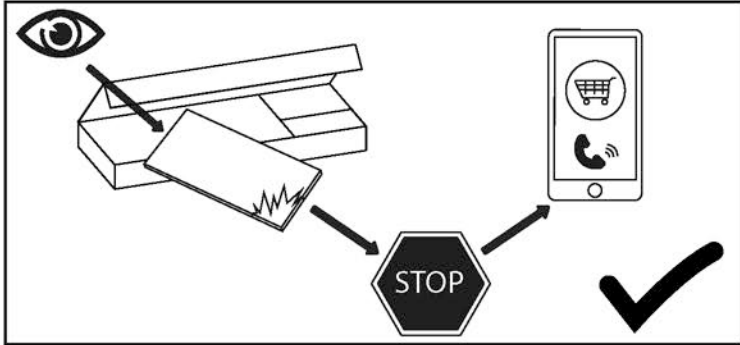
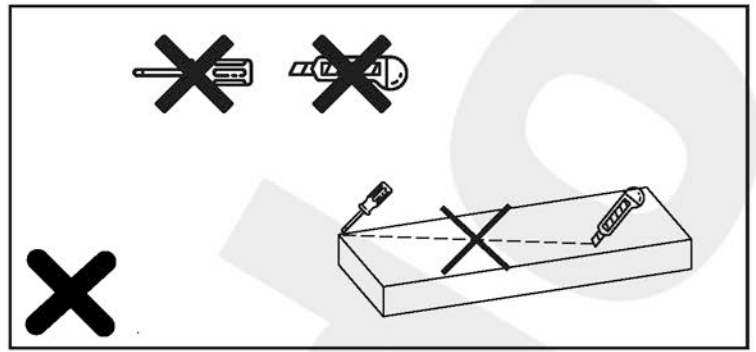
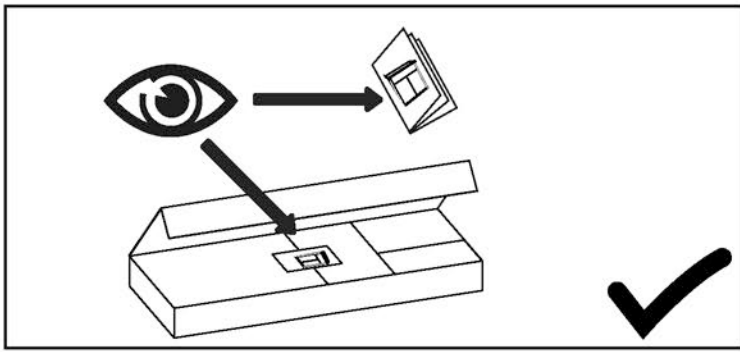



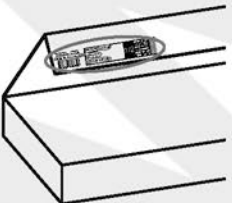

PL - Zachowaj w razie reklamacji !!! / BG - Пазете в случай на reclamaция !!! / CZ - Uchovávejte pro případ stížnosti !!! / DE - Bewahren Sie das Etikett für Reklamationen !!! / ENG - Keep the label for complaints !!! / ES - Conservar en caso de reclamación !!! / EST - Kaebuse korral hoidke alles !!! / FR - Conserver en cas de réclamation !!! / HR - Zadržite u slučaju prigovora !!! / HU - Tartsa fenn panaszi esetén !!! / IT - Conservare in caso di reclamo !!! / LT - Laikykite skundo atveju !!! / LV - Saglabājiet sūdzības gadījumā !!! / NL - Bewaren in geval van een klacht !!! / PO - Guardie em caso de reclamação !!! / RO - Păstrați în cazul unei reclamații !!! / RU - Сохранить в случае рекламации !!! / S - Föörvara vid klagomål !!! / SK - Majte v prípade reklamácie !!! / SLO - Hranite v primeru pritožbe !!! / SRB - Zadržite u slučaju žalbe !!! / TR - Şikayet durumunda saklayın !!! / UKR - Зберігати у разі скарги !!!





Data produkciji: Pakujący
Lot of production: Packager

0000-00-00 xxx/xxx/xxx



010000000000000000000000

Nazwa wyrob.: XXXXX 00
Product name:
Kolor: XXX XXXX
Color: XXX XXXX
OXXXX00-000-0/0

1/2	Brutto/gros
00.0 00	KG
000	netto/net
0	KG
0	m ³
0	0.000

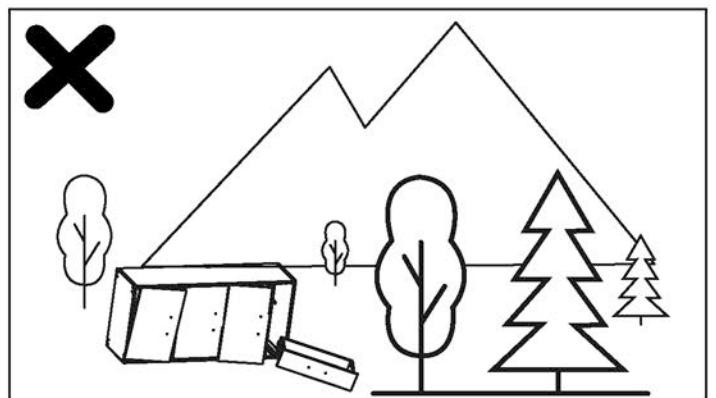
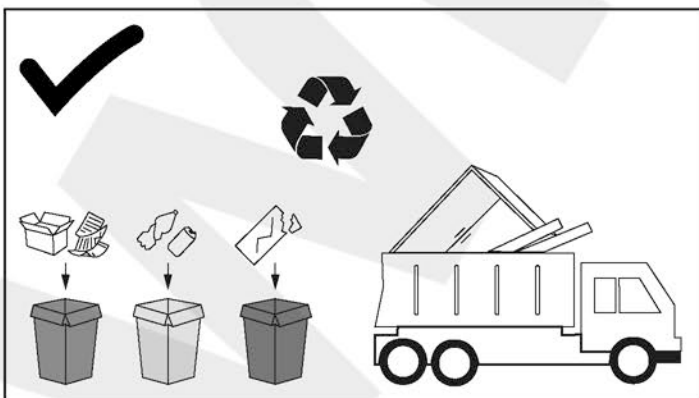
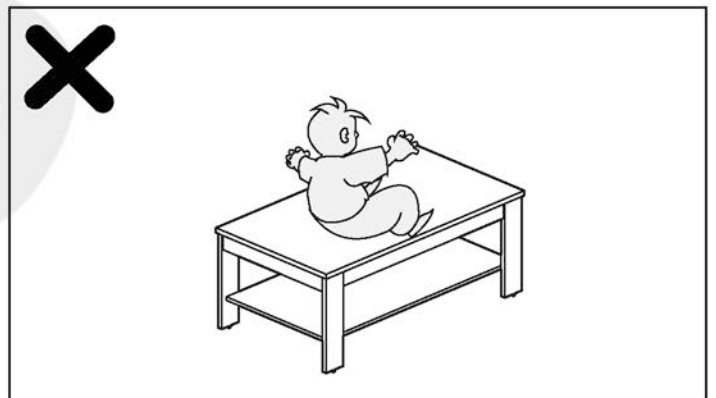
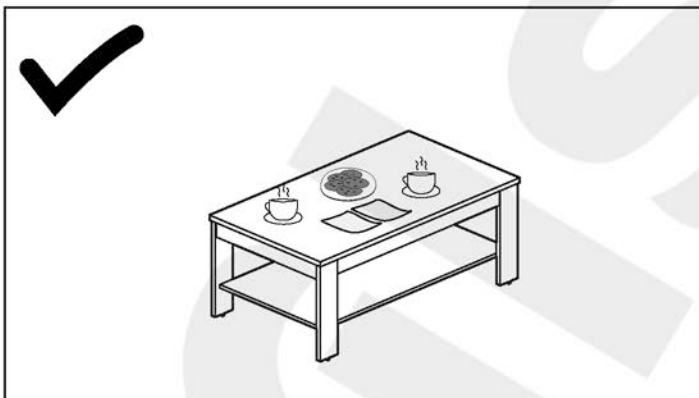
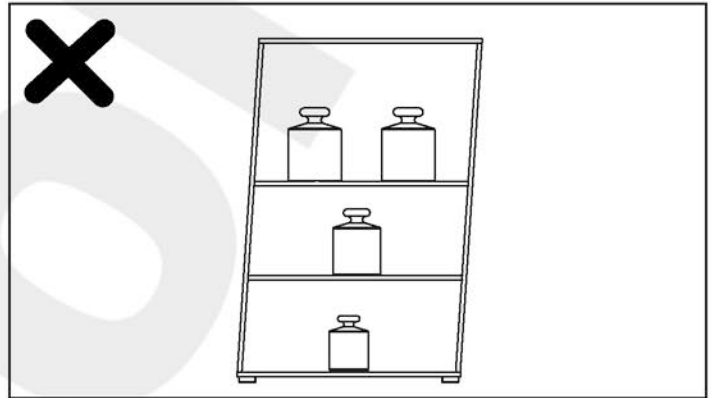
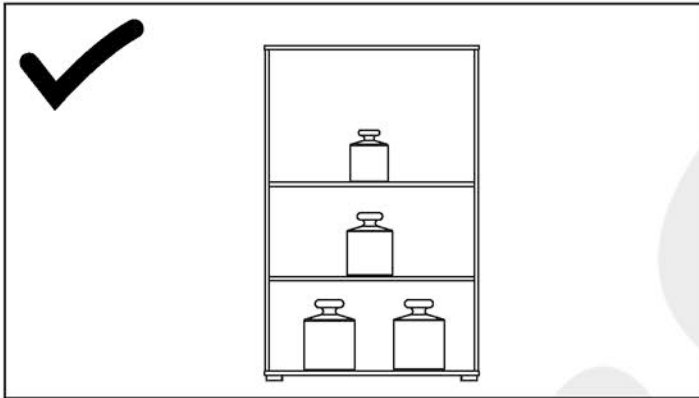
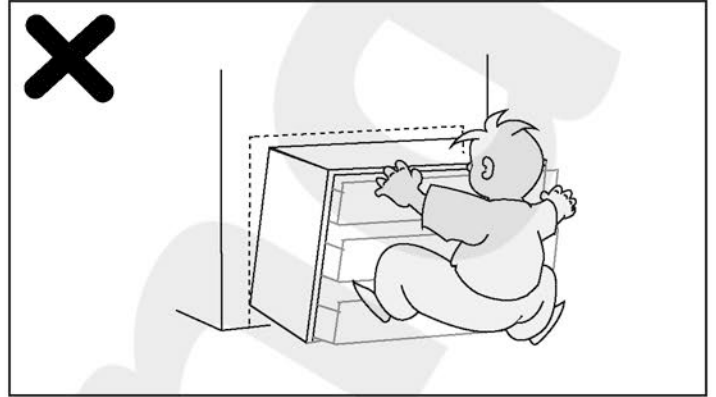
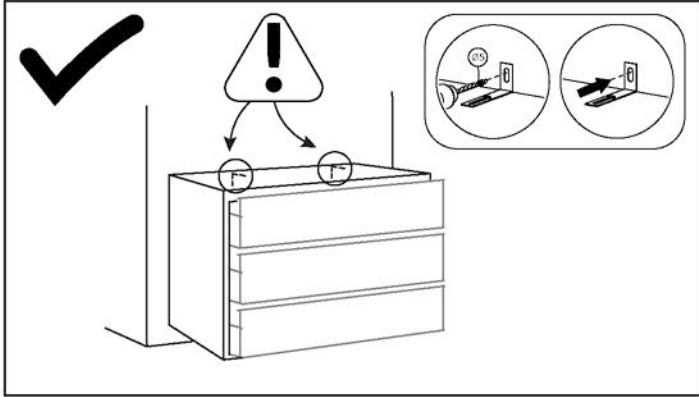

	kod/code/kód					
1	Mevel08_01	934	892	16	1	1/2
2	Mevel08_02	934	396	16	1	1/2
3	Mevel08_03	2032	178	16	2	2/2
4	Mevel08_04	900	249	16	1	1/2
5	Mevel08_05	900	124	16	1	1/2
6	Mevel08_06	900	80	16	2	1/2
7	Mevel08_07	160	736	16	1	1/2
8	Mevel08_08	160	736	16	1	1/2
9	Mevel08_09	1130	160	16	1	1/2
10	Mevel08_10	1162	736	16	1	1/2
11	Mevel08_11	50	998	22	4	2/2
12	Mevel08_12	1200	207	16	1	1/2
13	3Mevel08_13_KASZ	310	497	35	3	1/2
14	WKL-90-002	2000	900	8	1	1/2
15						

	kod/code/kód					
16						
17						
18						
19						
20						
21						
22						
23						
24						
25						
26						
27						
28						
29						
30						

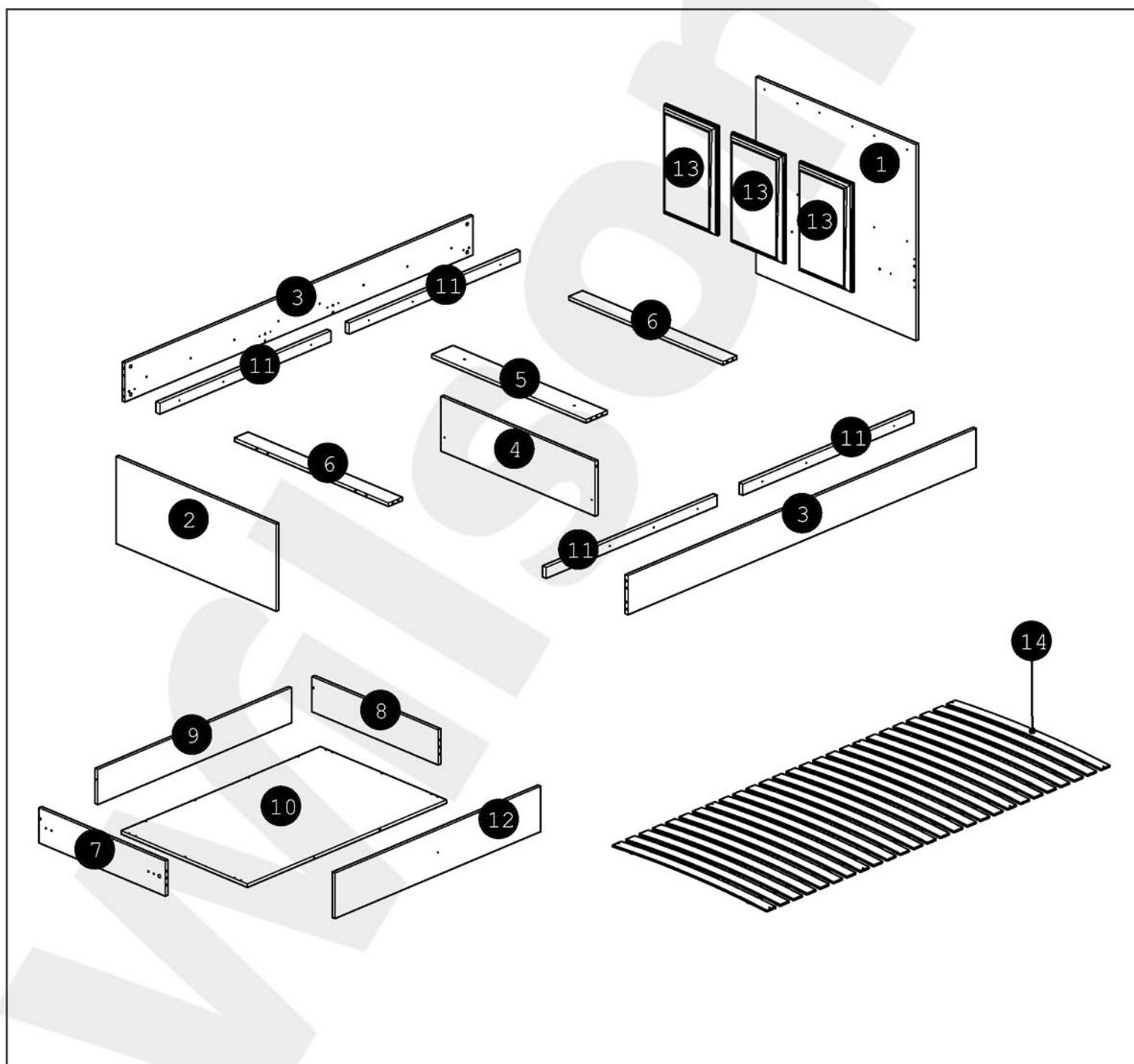

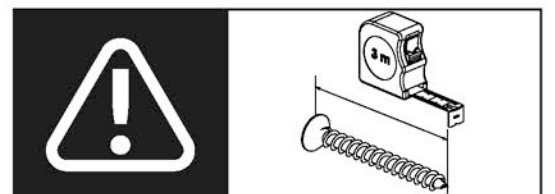
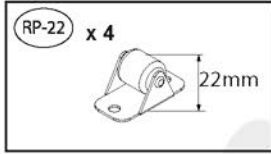
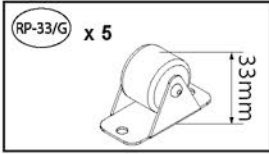
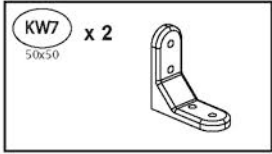
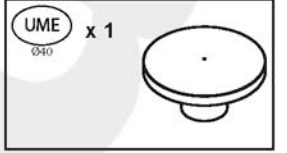
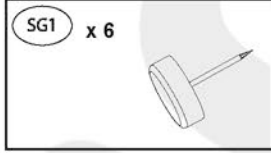
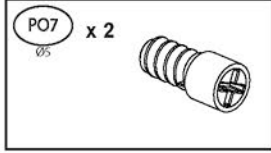
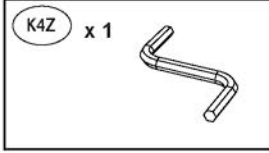
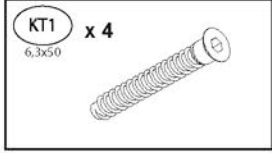
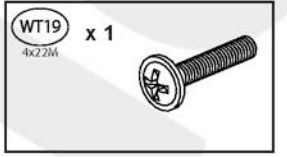
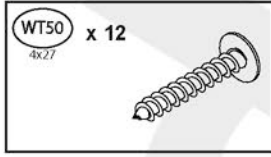
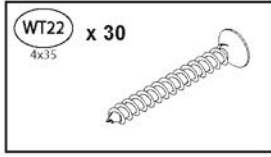
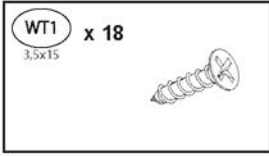
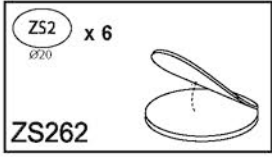
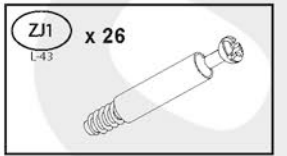
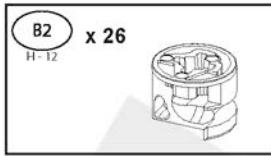
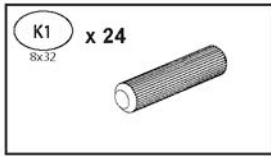

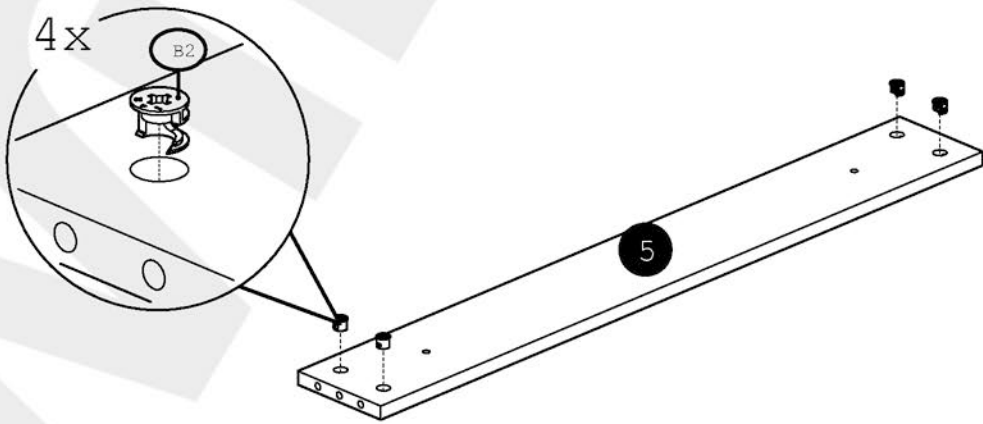
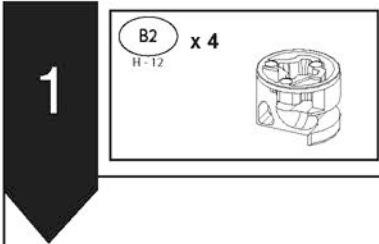
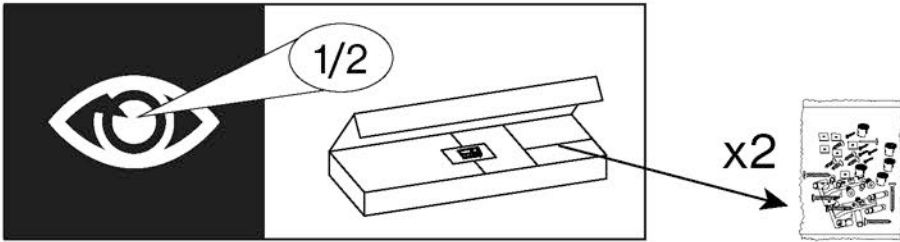
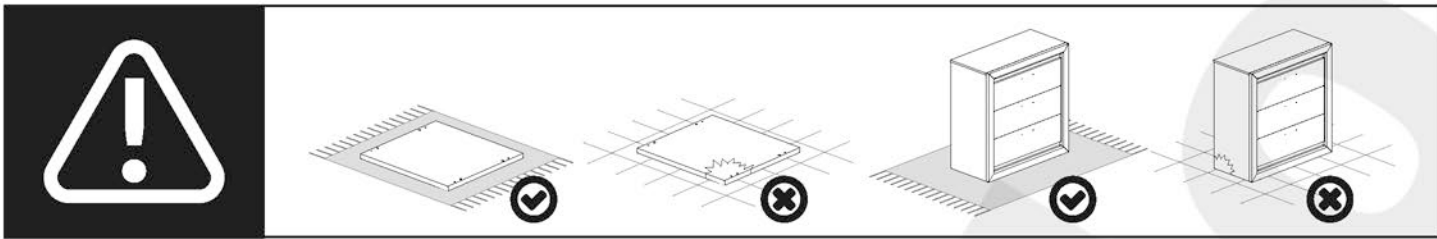

2

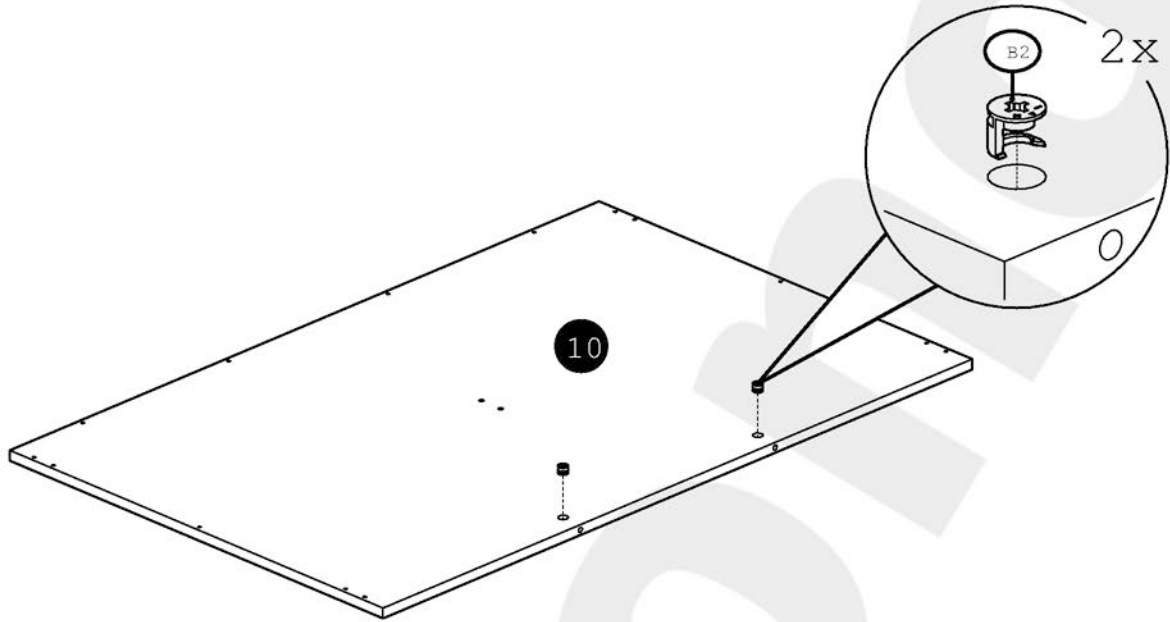
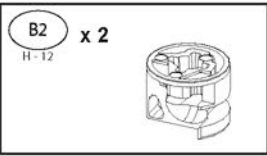

3

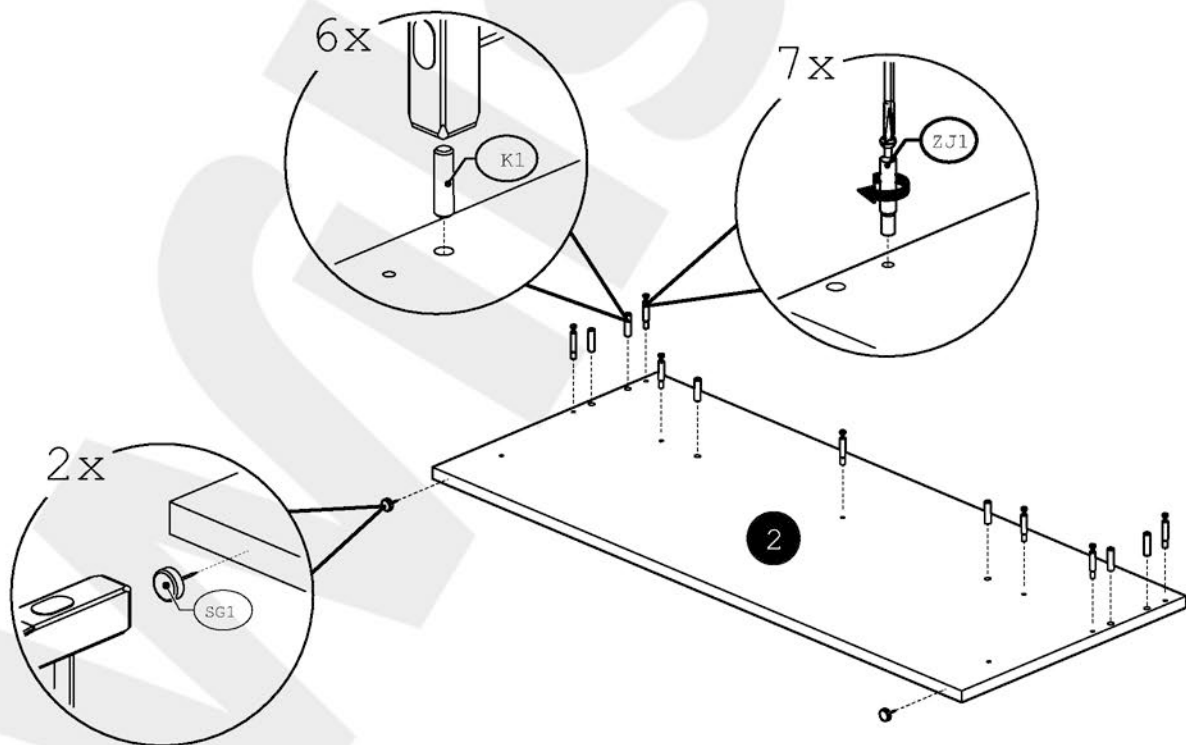
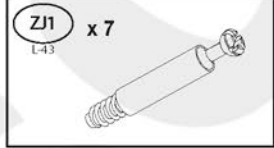
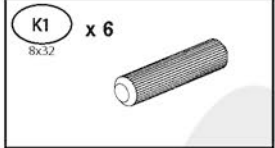
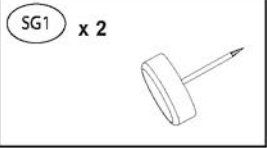

4

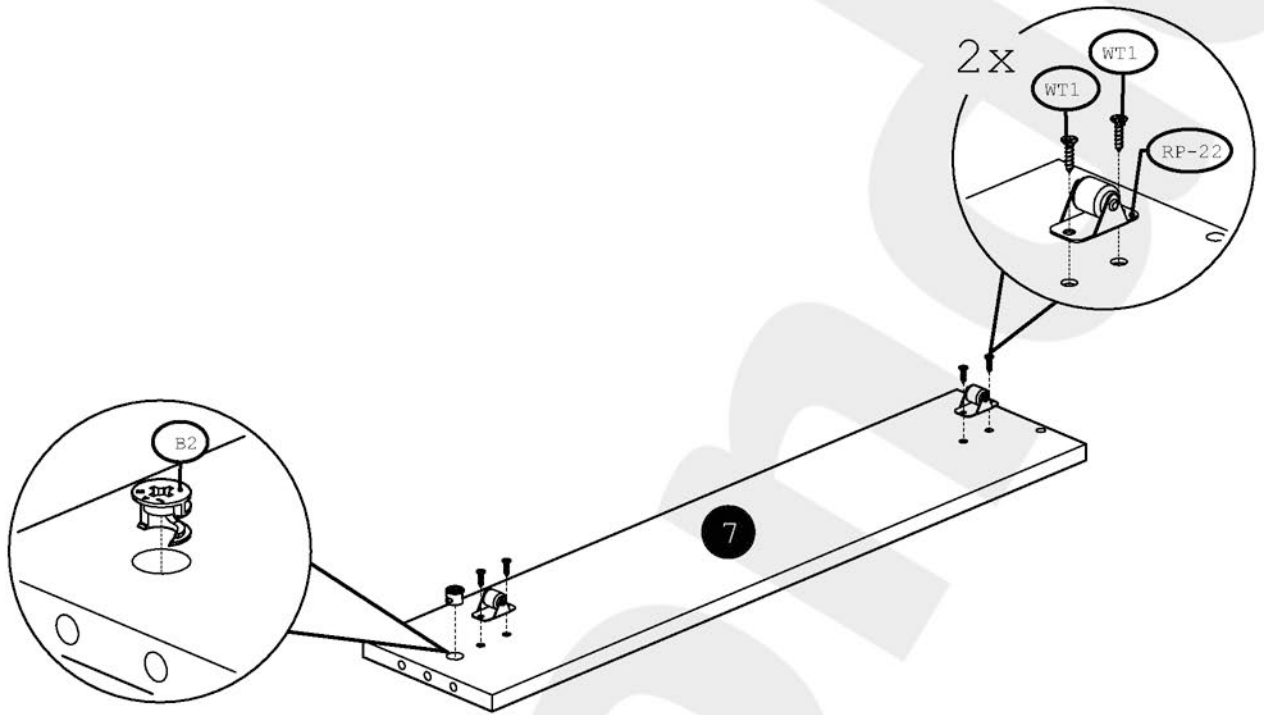
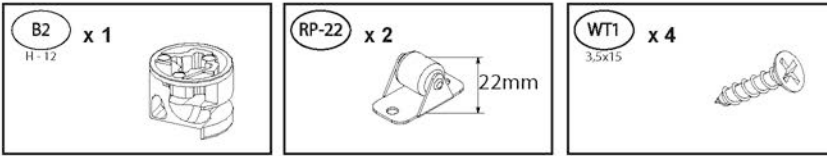

5

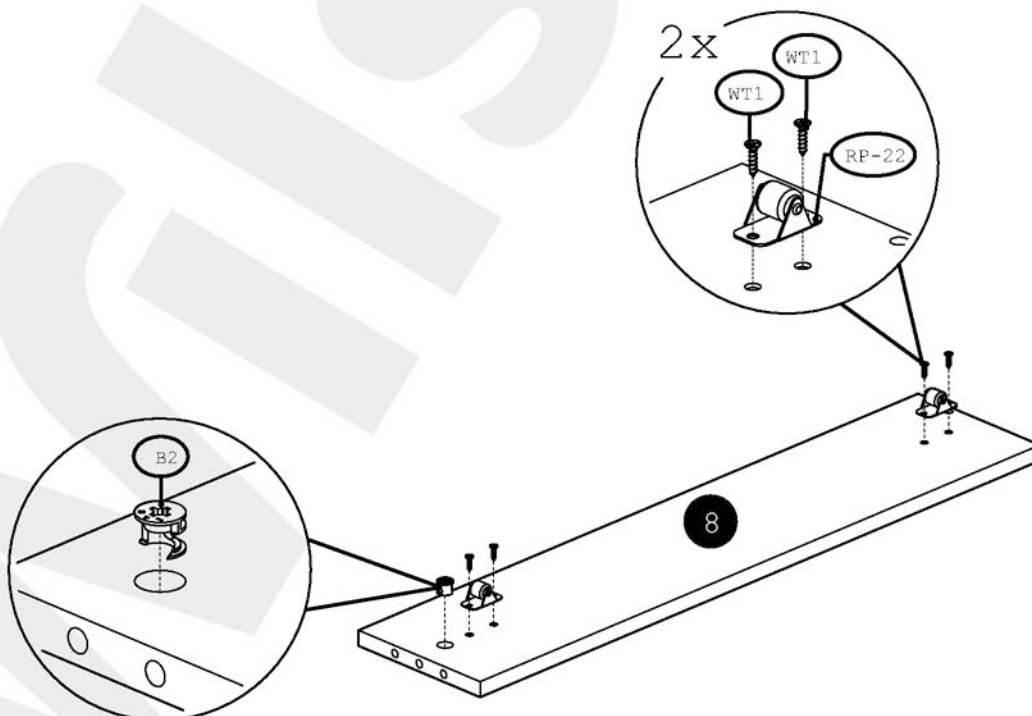
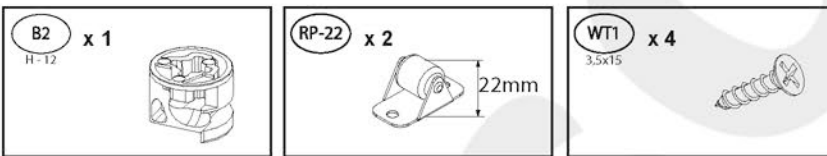

6

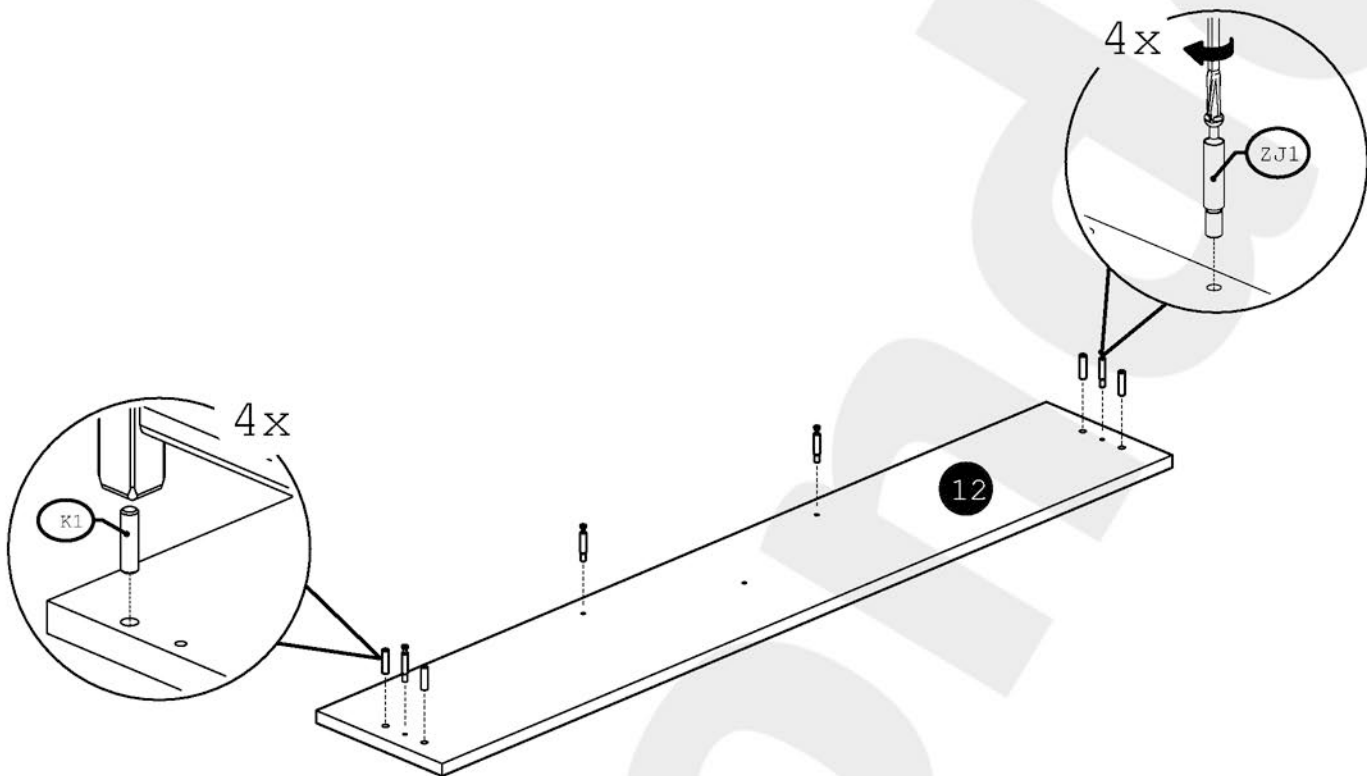
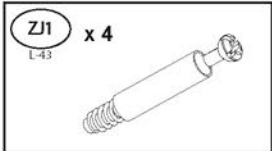
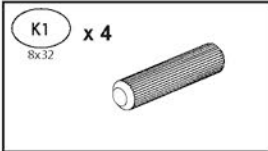

7

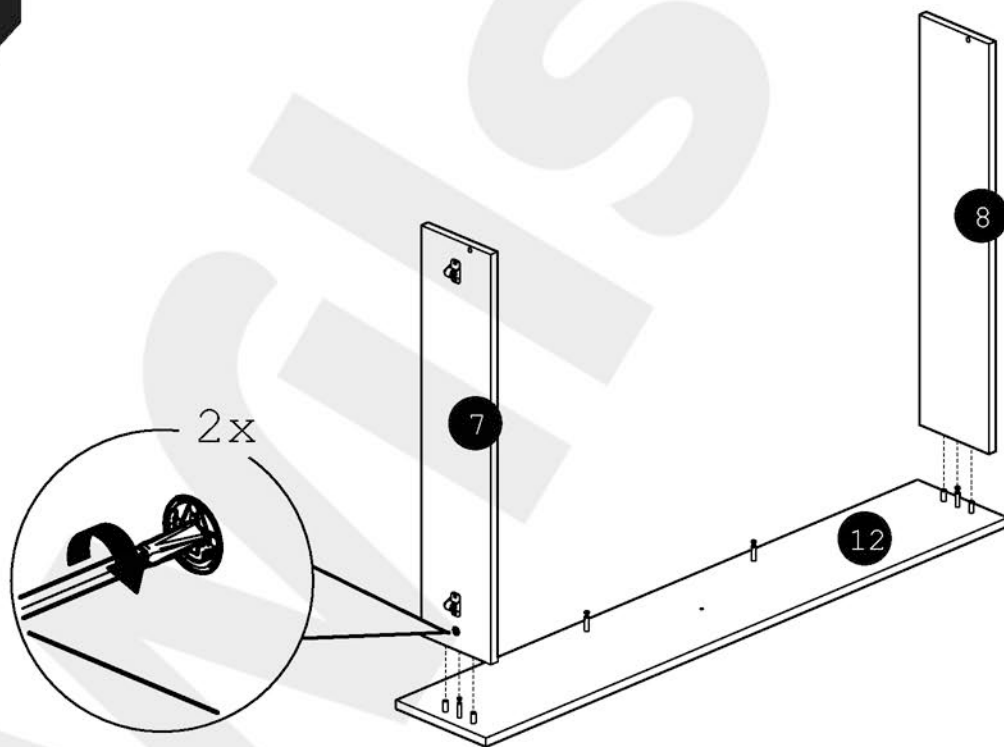

8

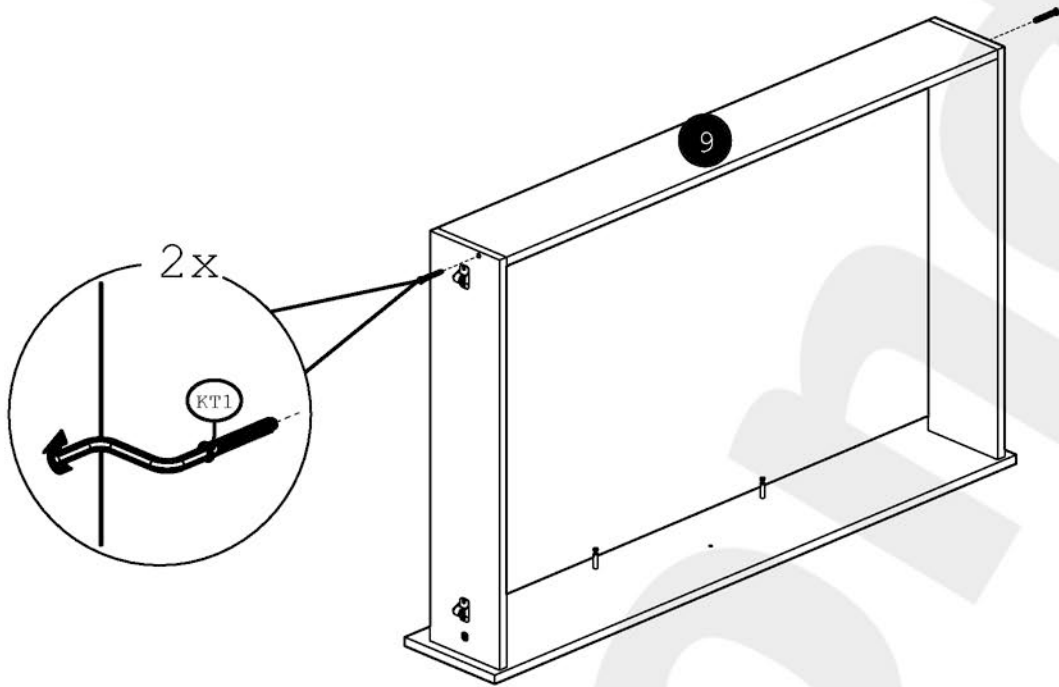
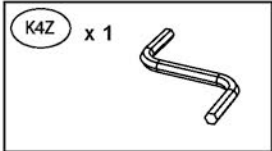
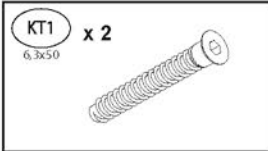

9

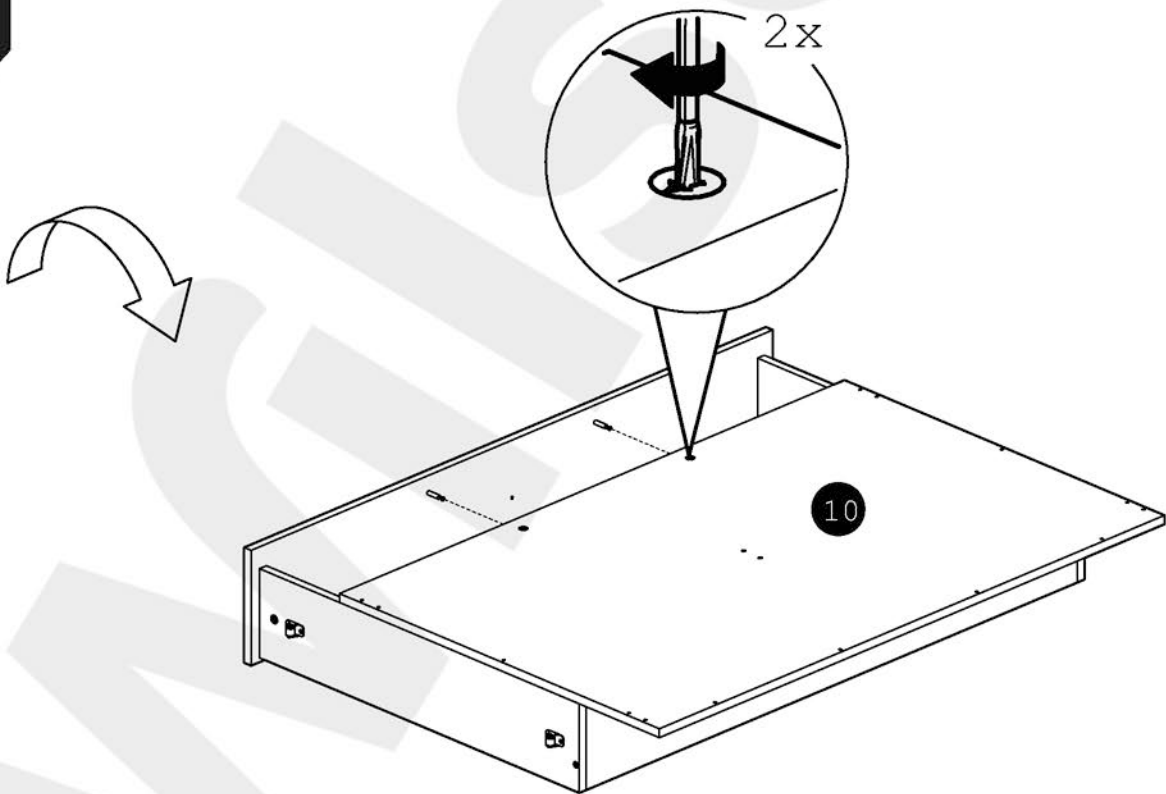

10

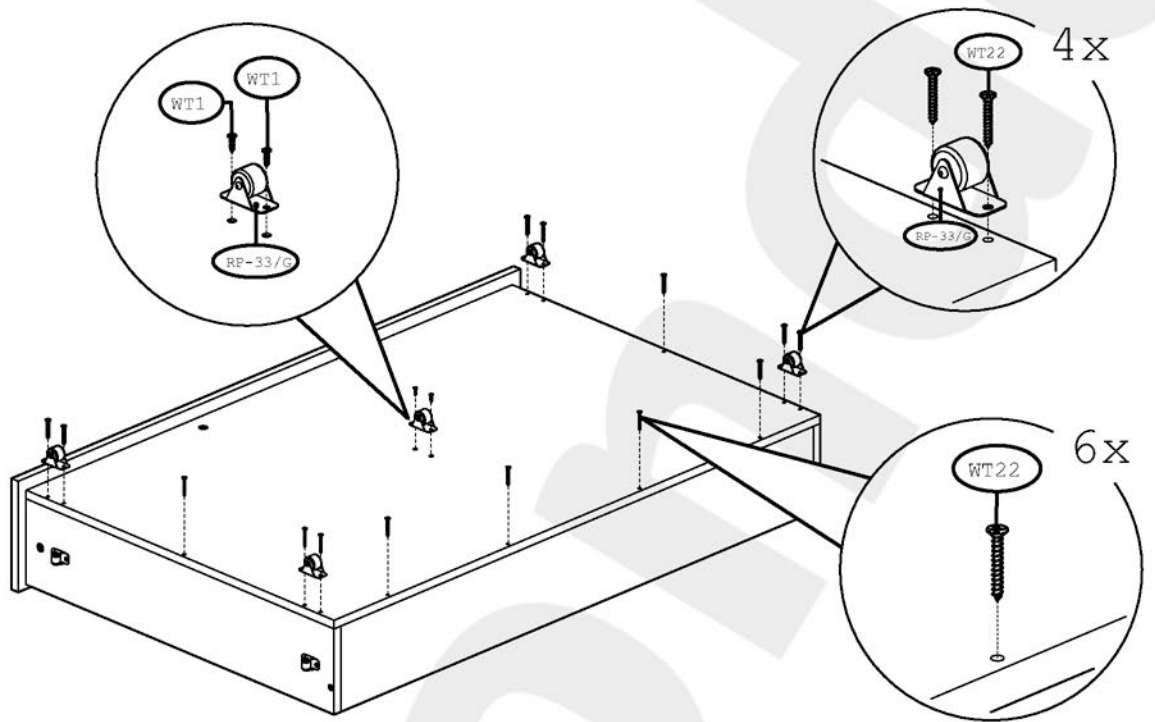
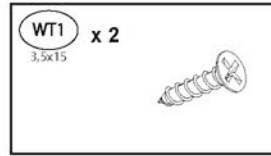
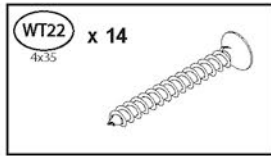
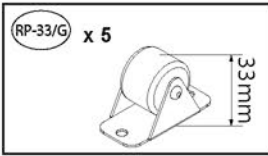

11

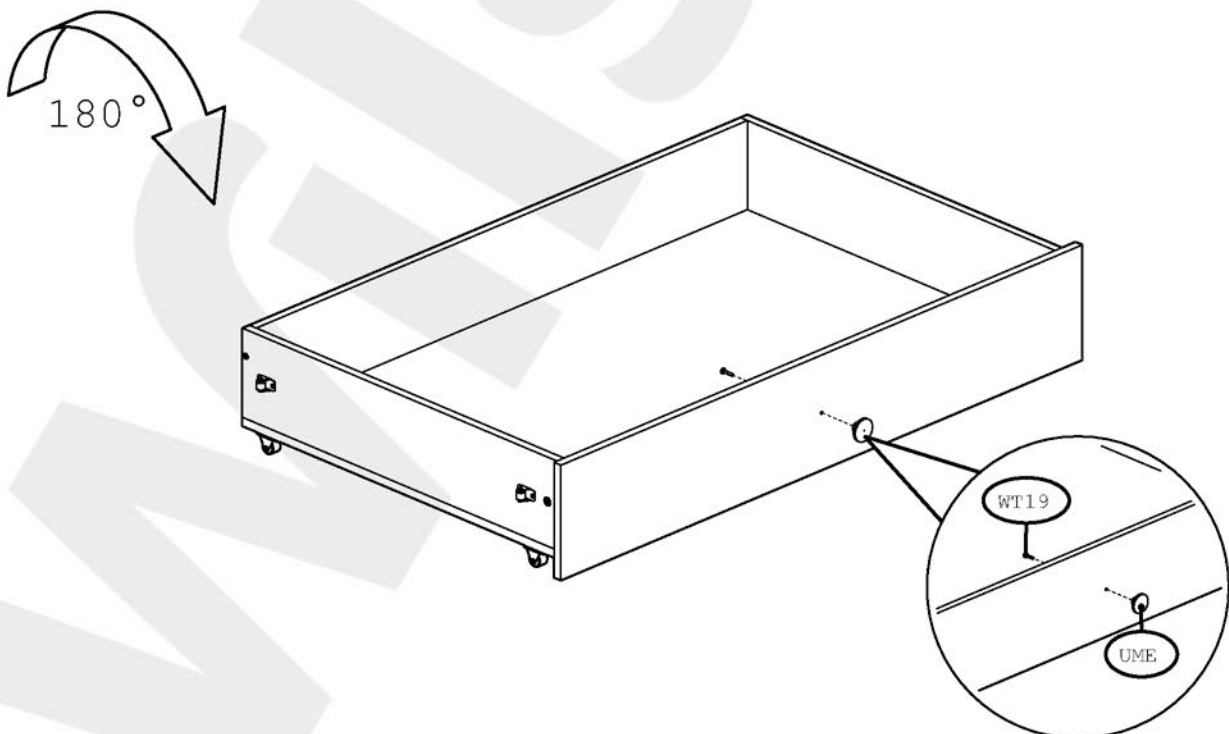
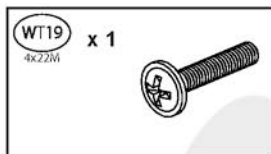
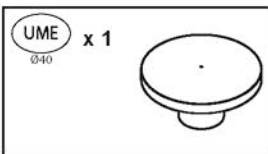

12

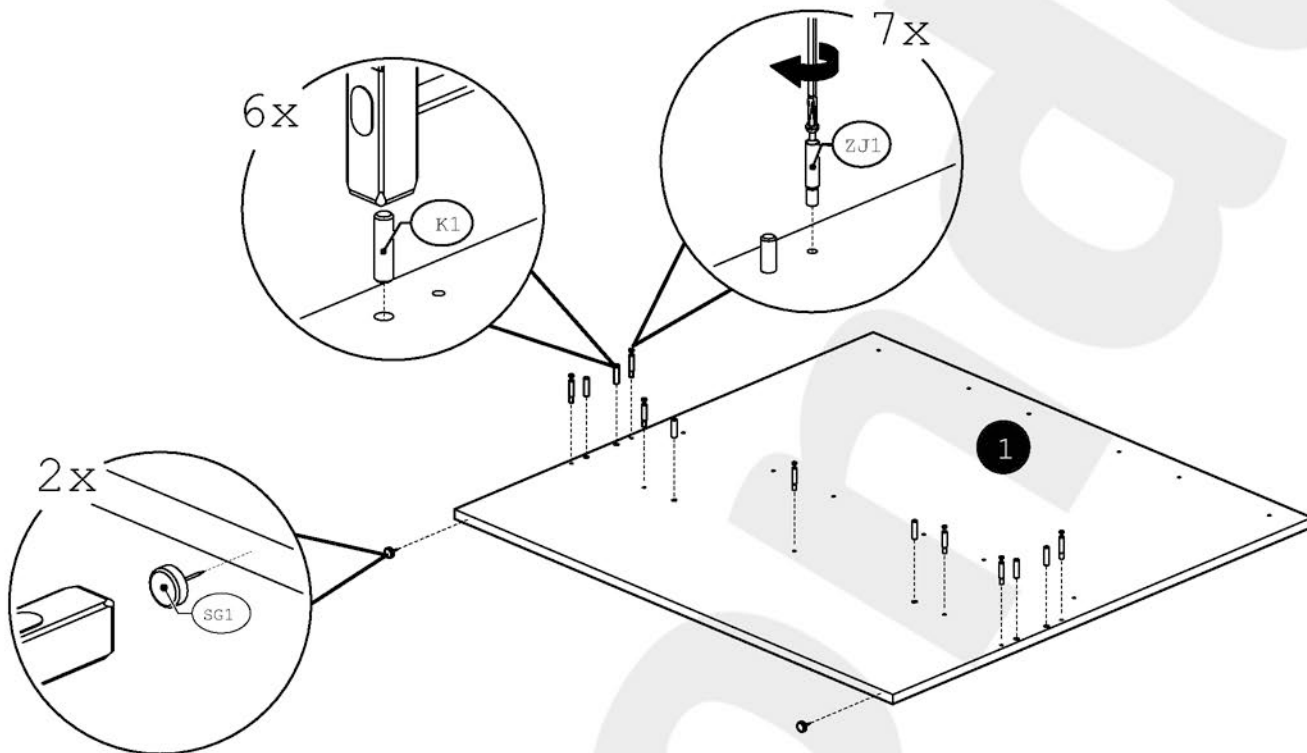
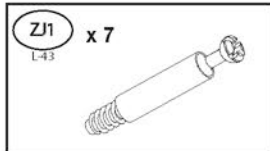
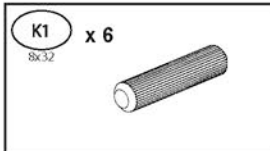
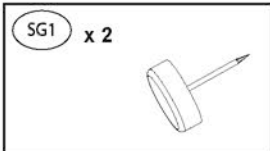

13

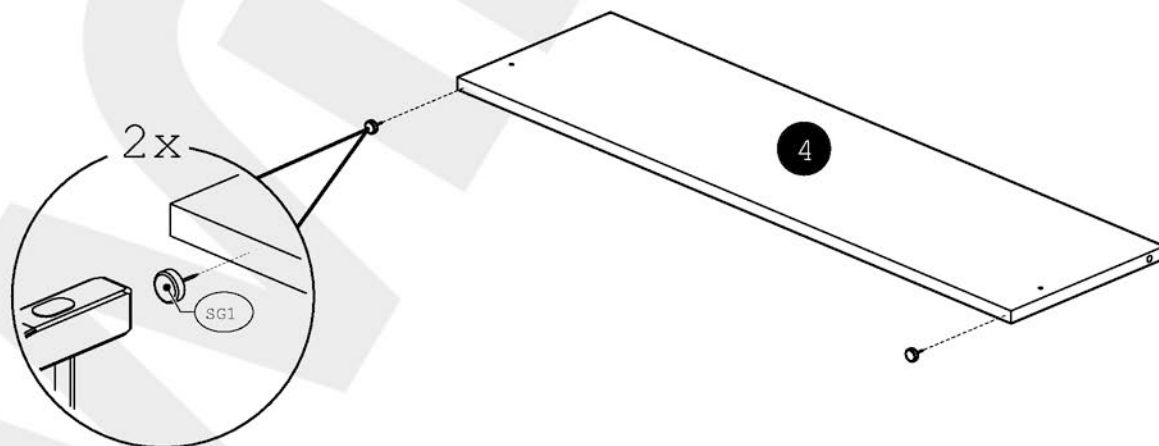
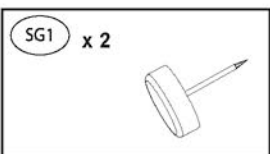

16

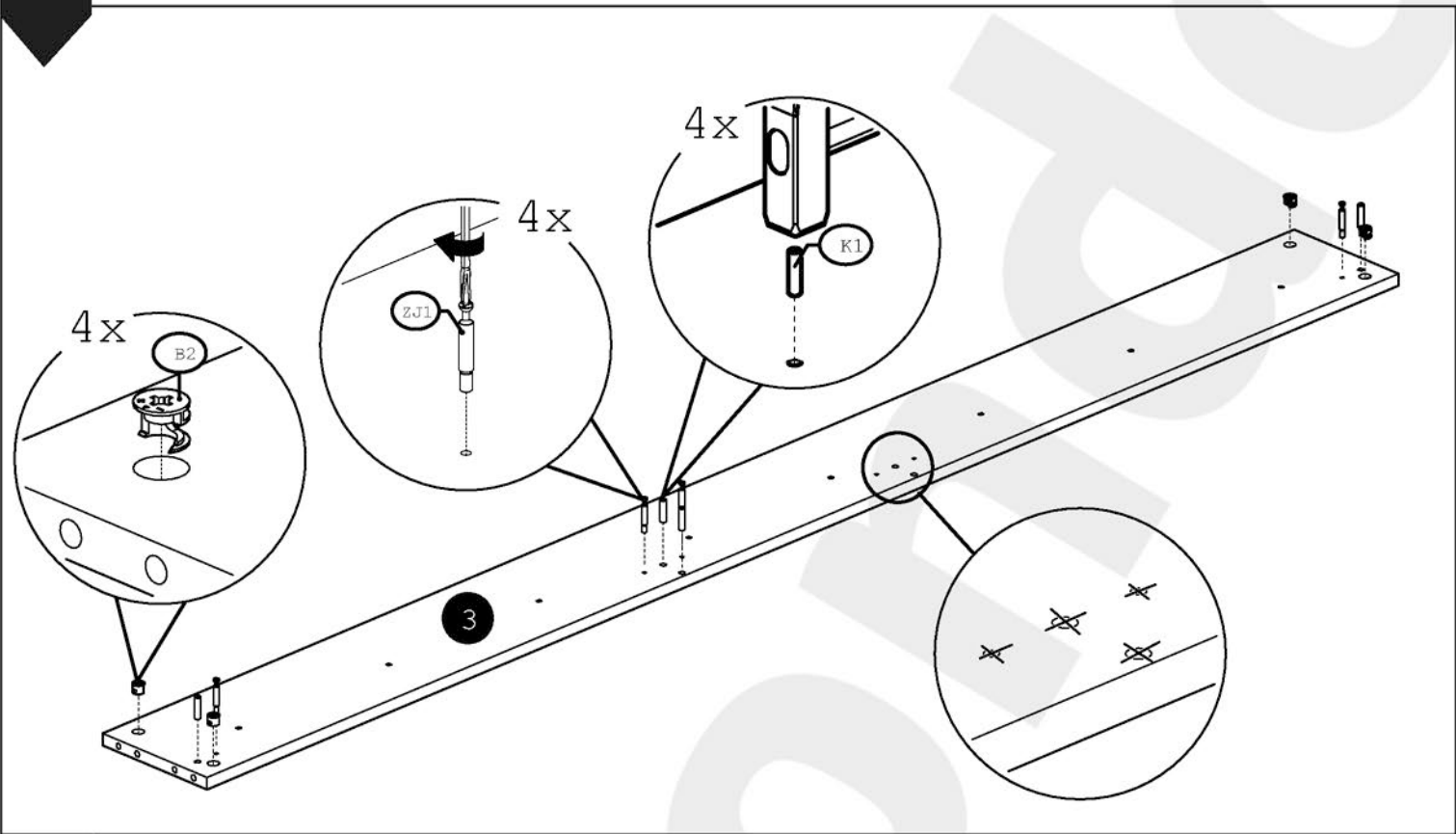
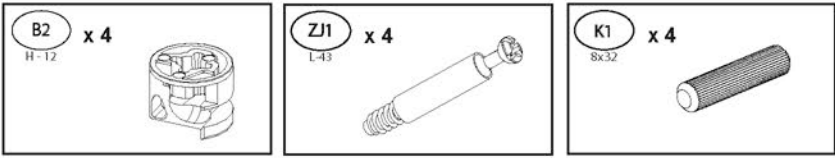

17

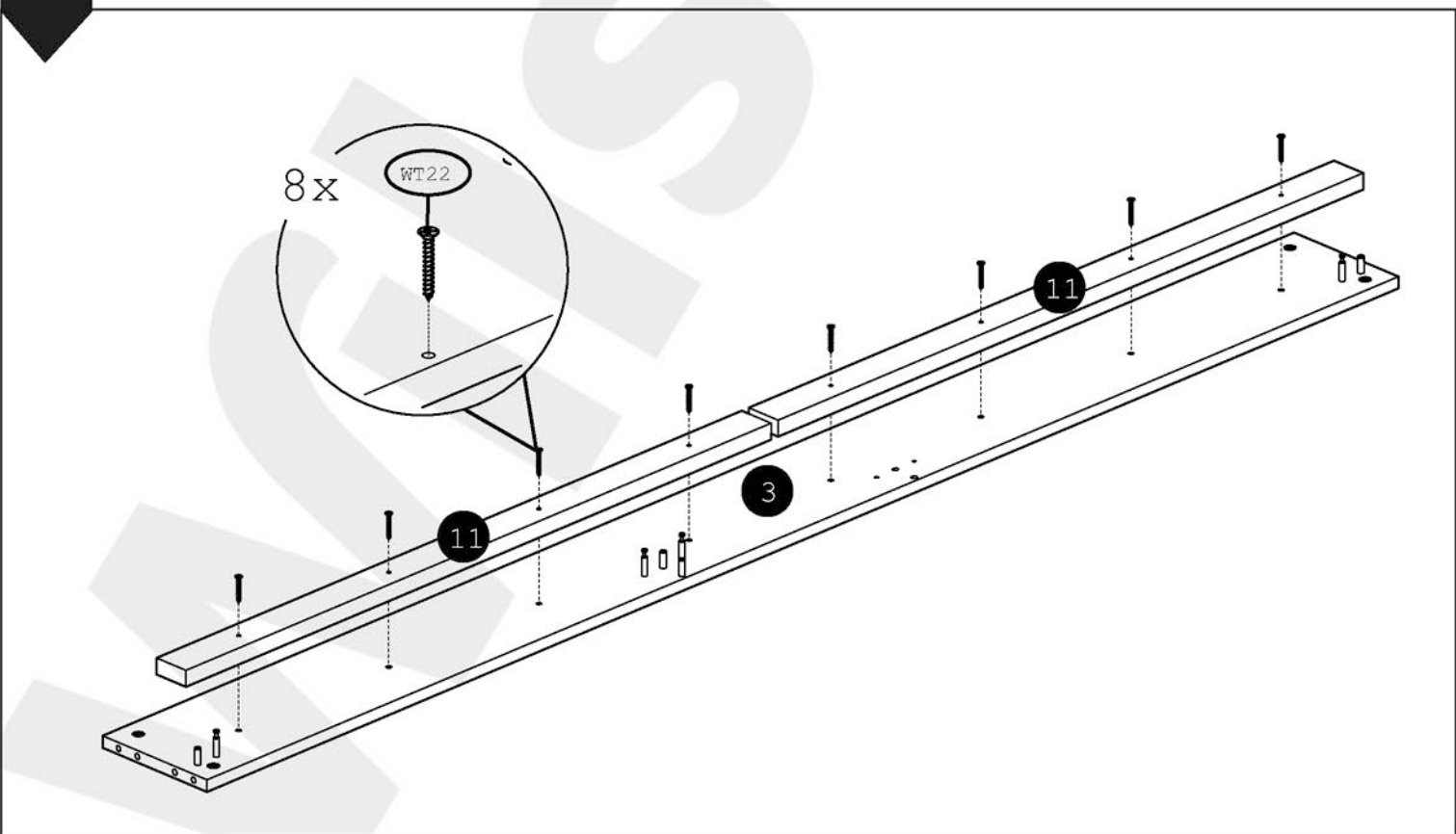
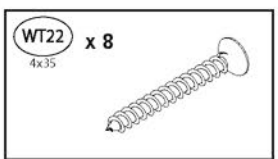

18

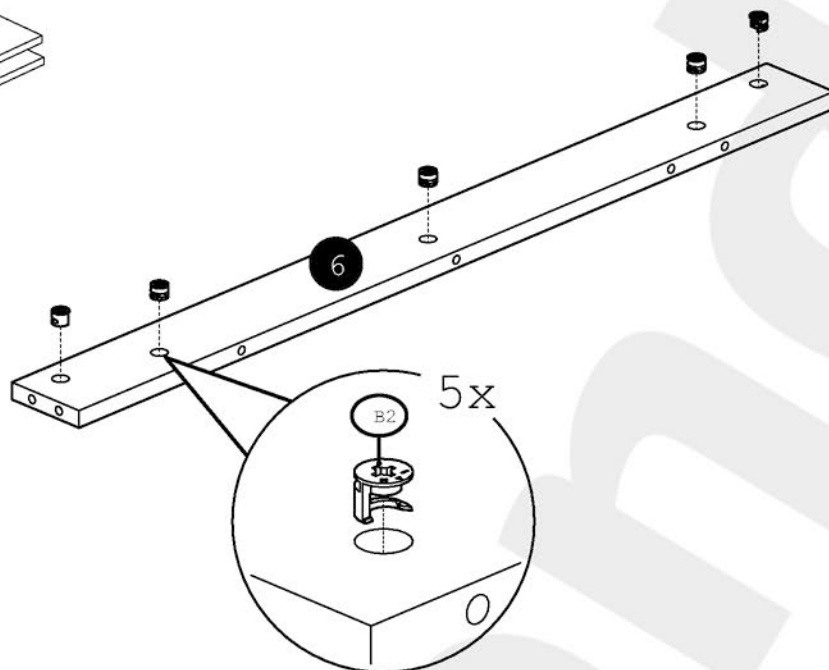
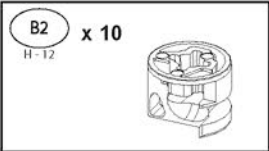

19

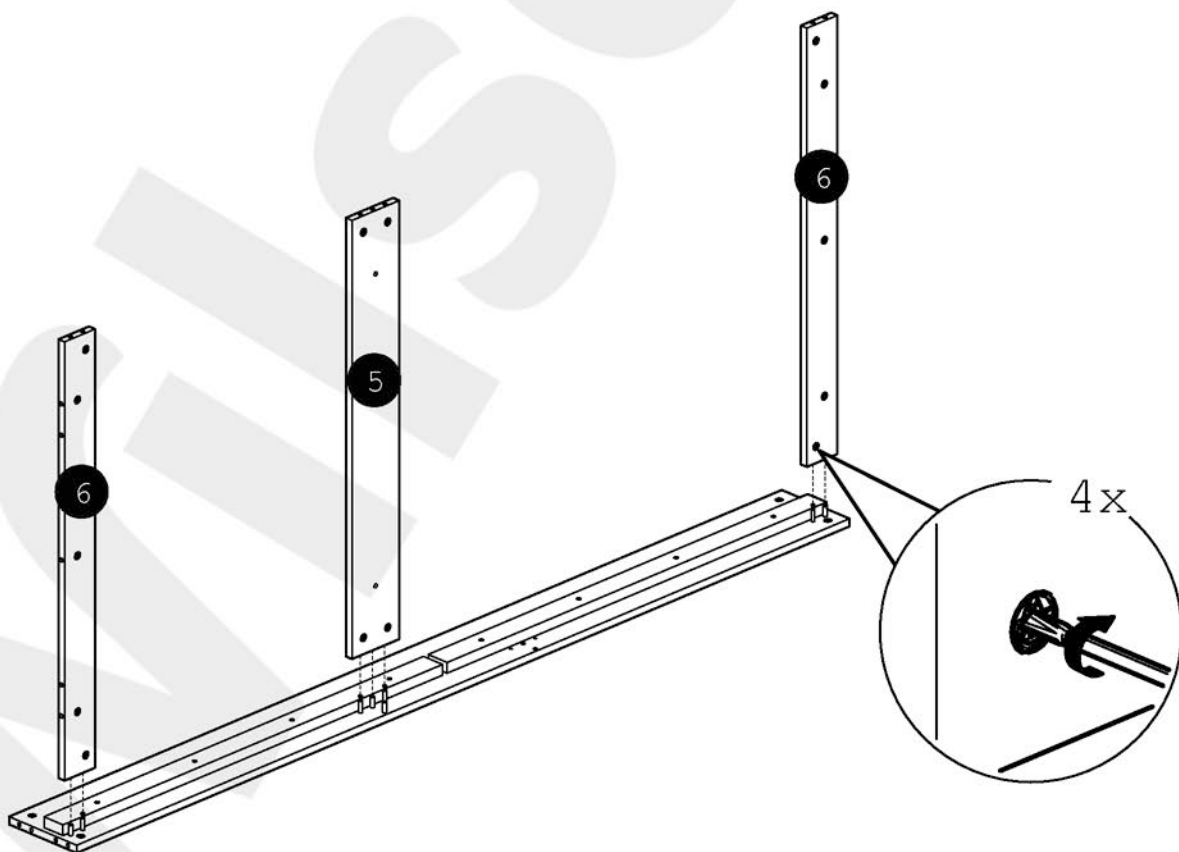

20

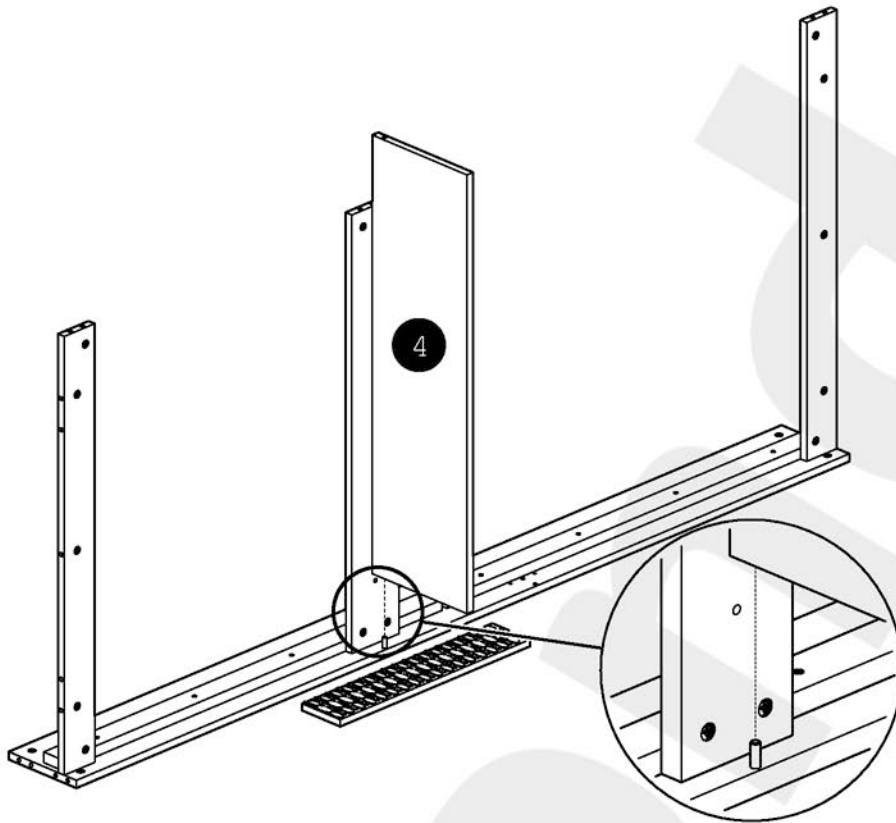

21

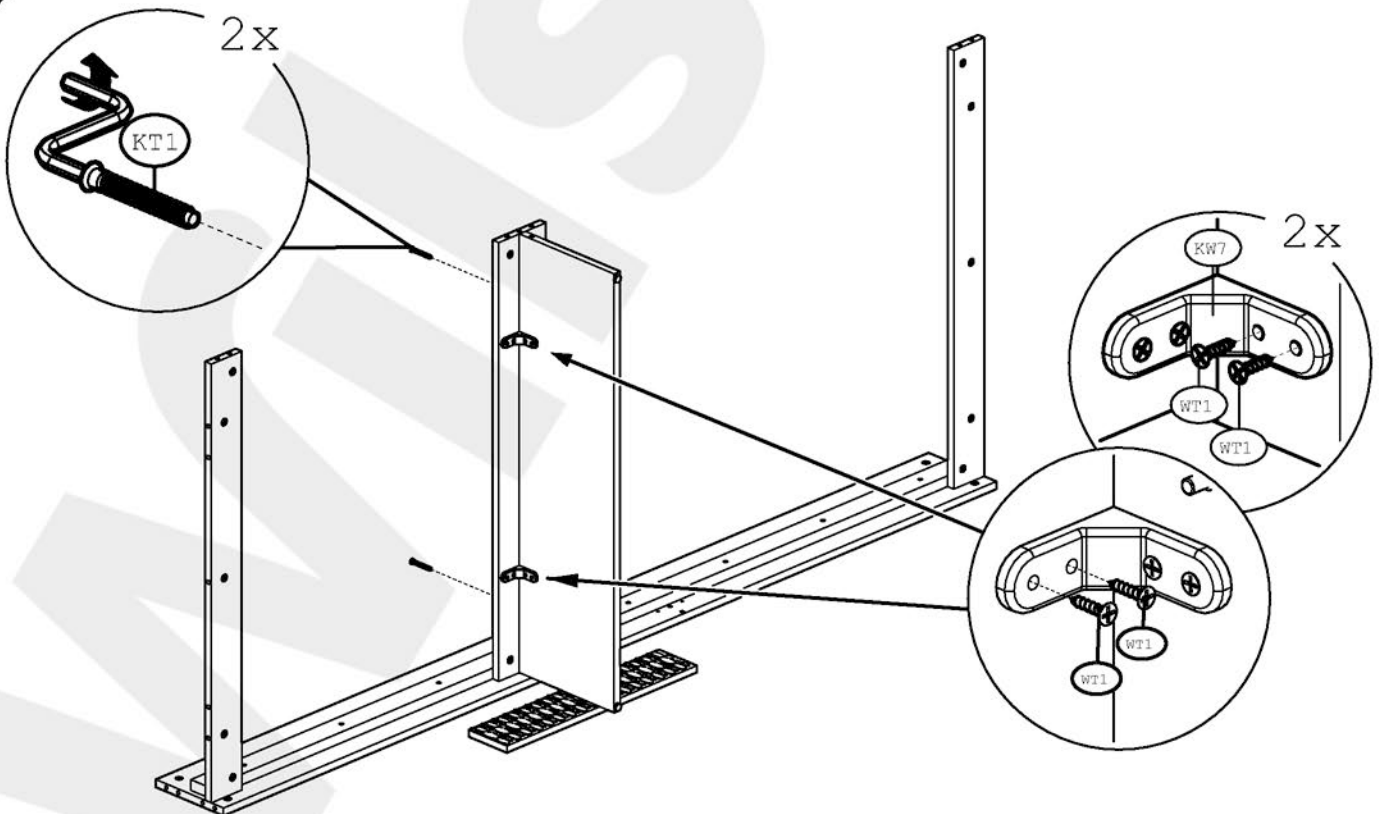
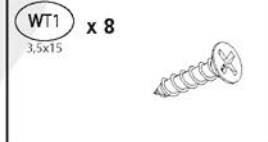
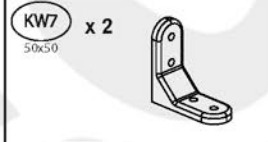
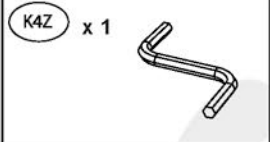
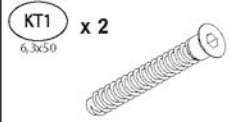

22

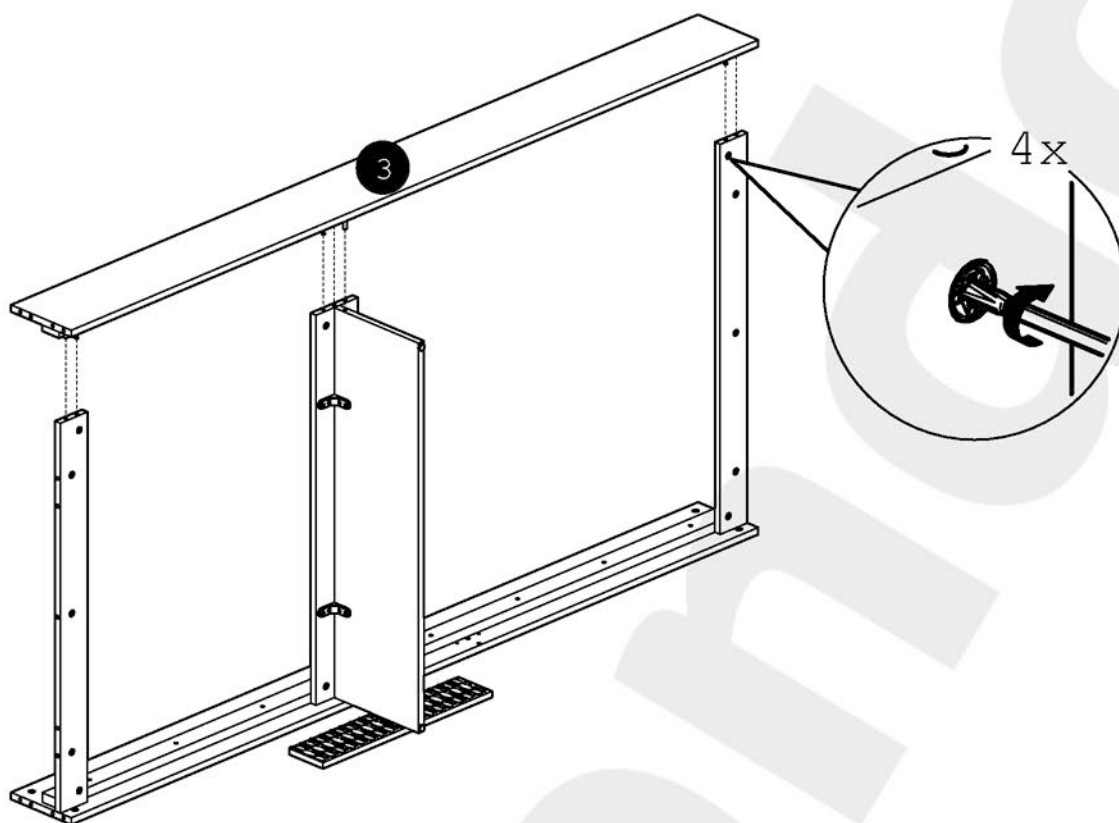

23

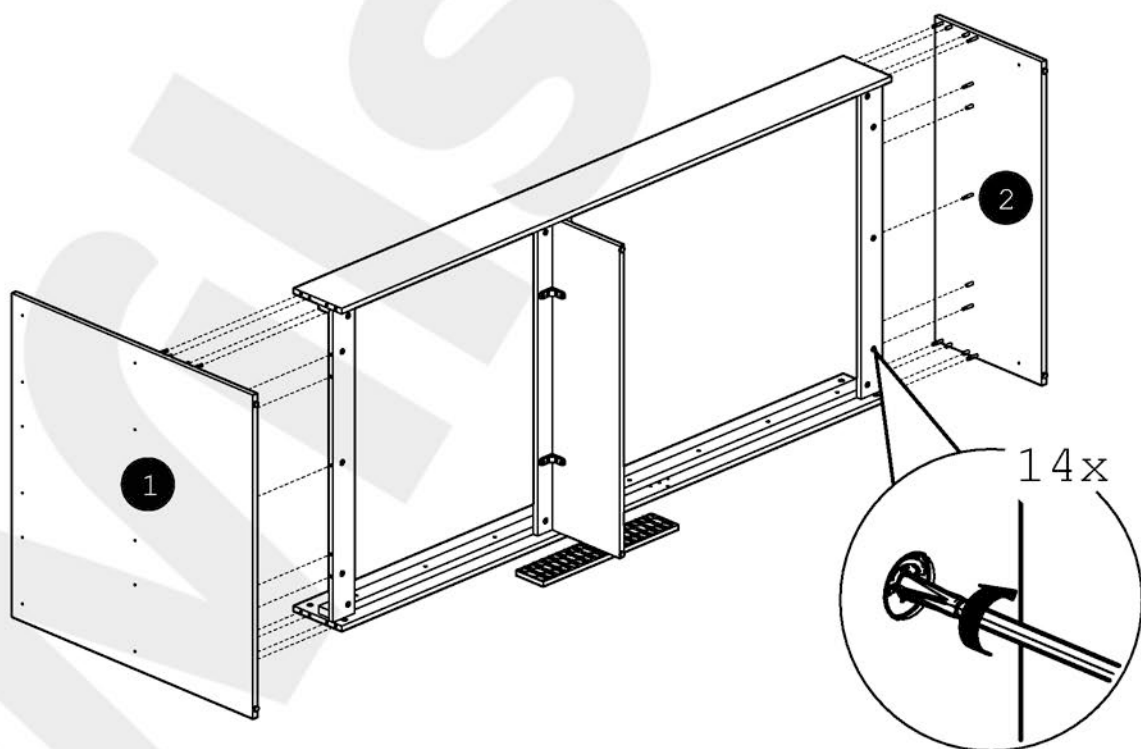

24

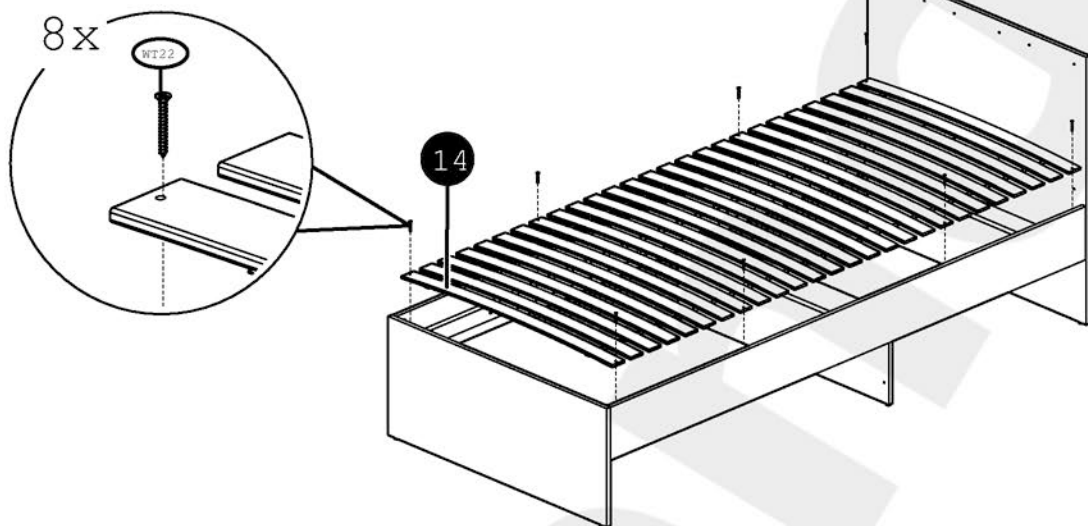
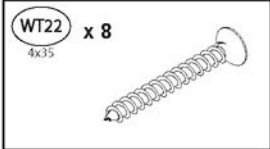

25

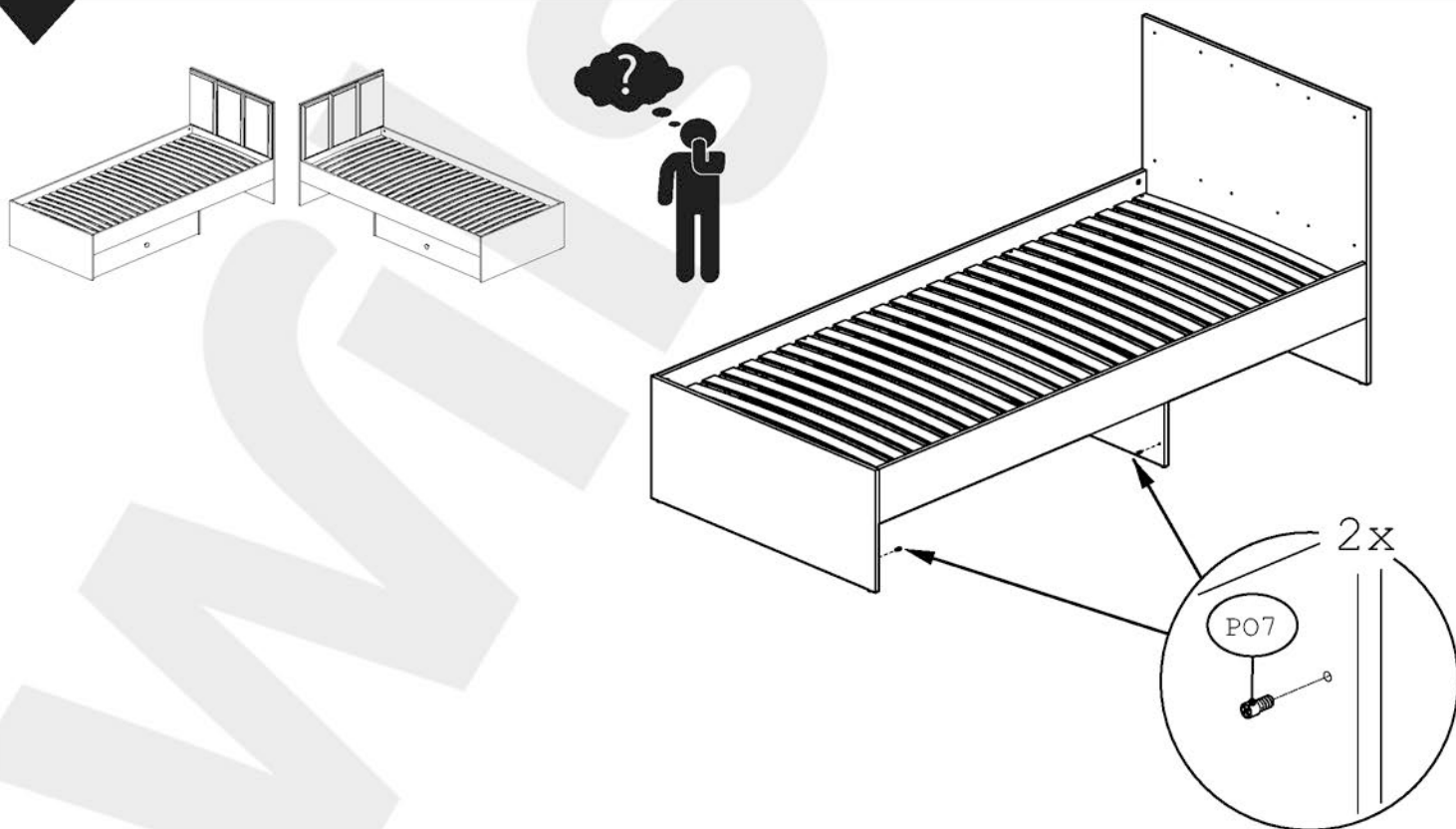
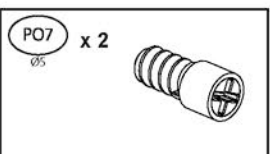

26

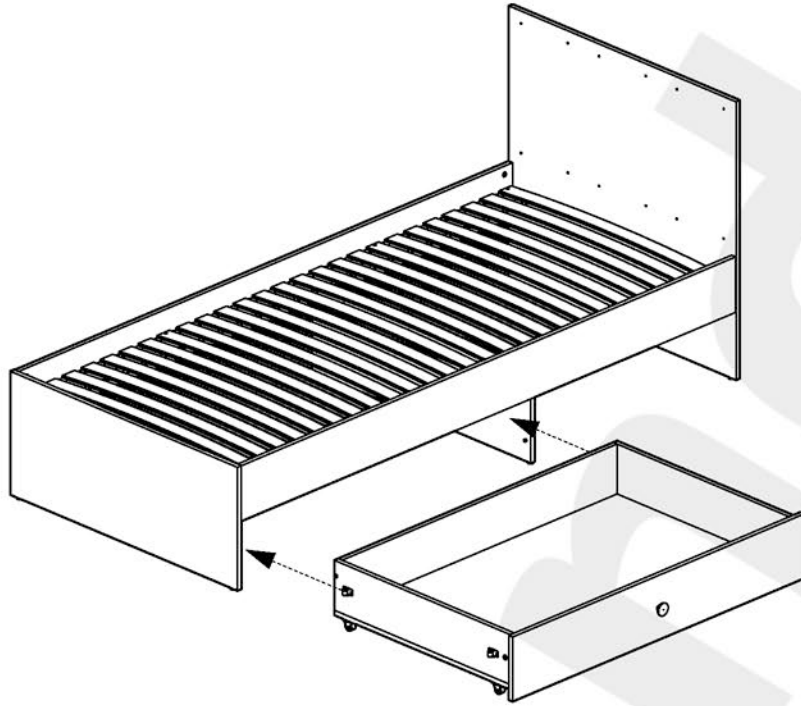

27

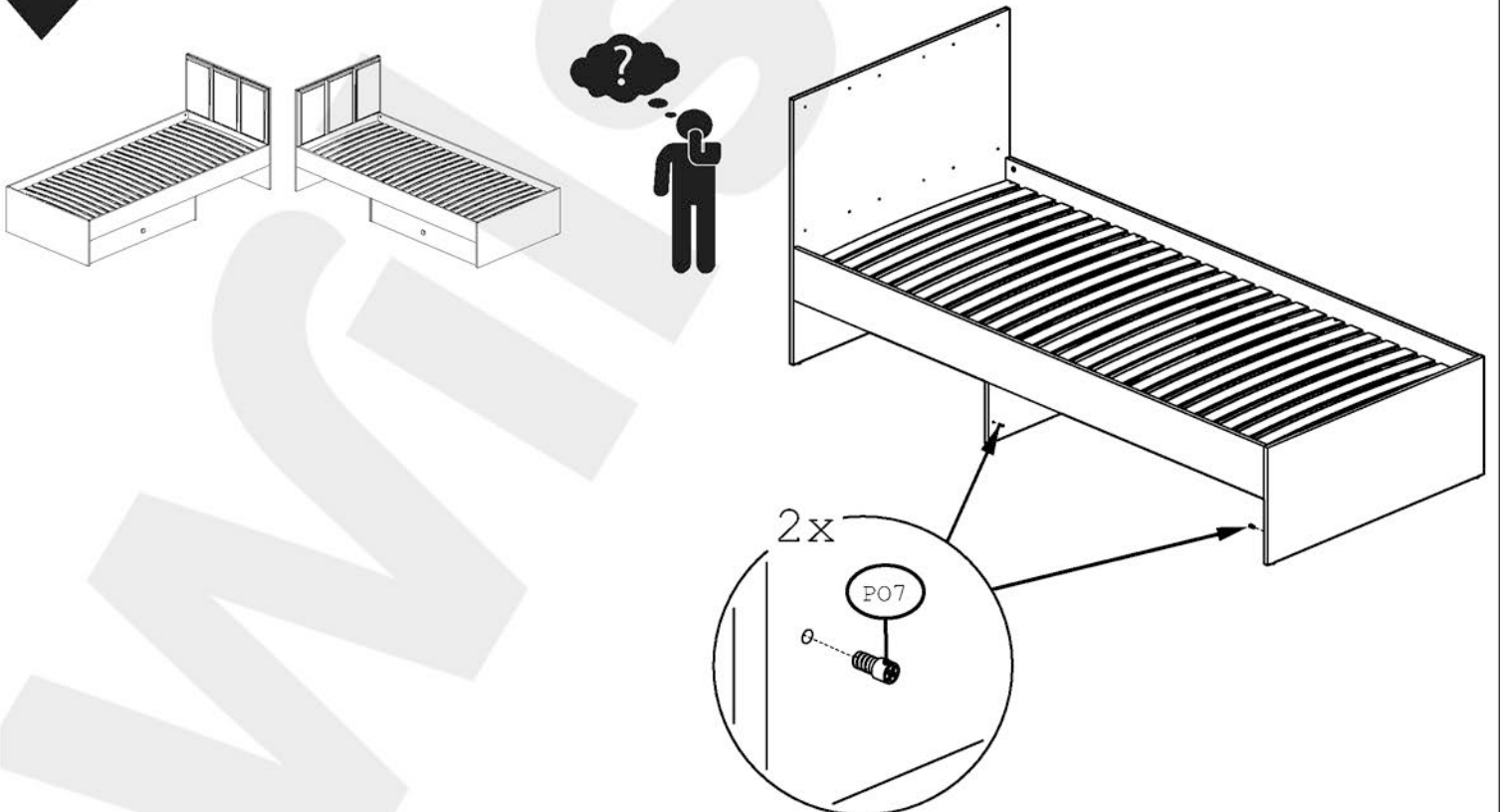
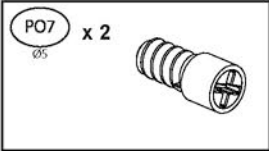

28

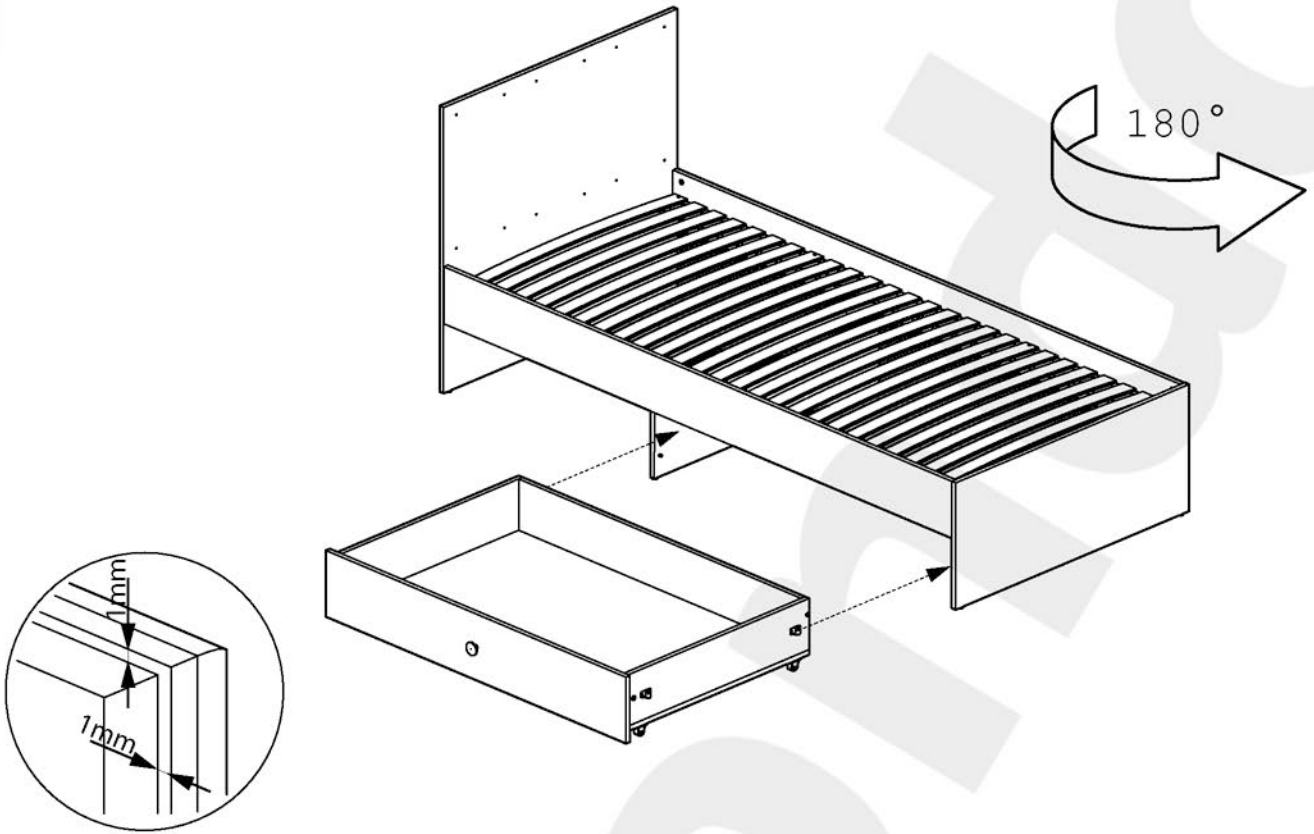

29

WT50 x 12
4x27

