

2

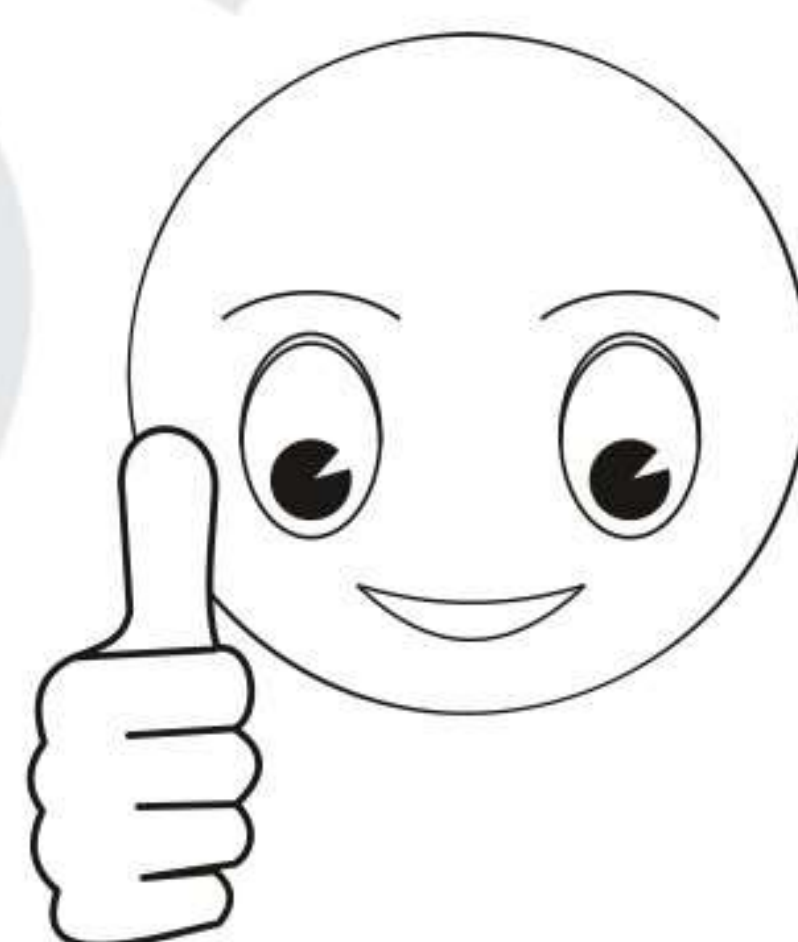
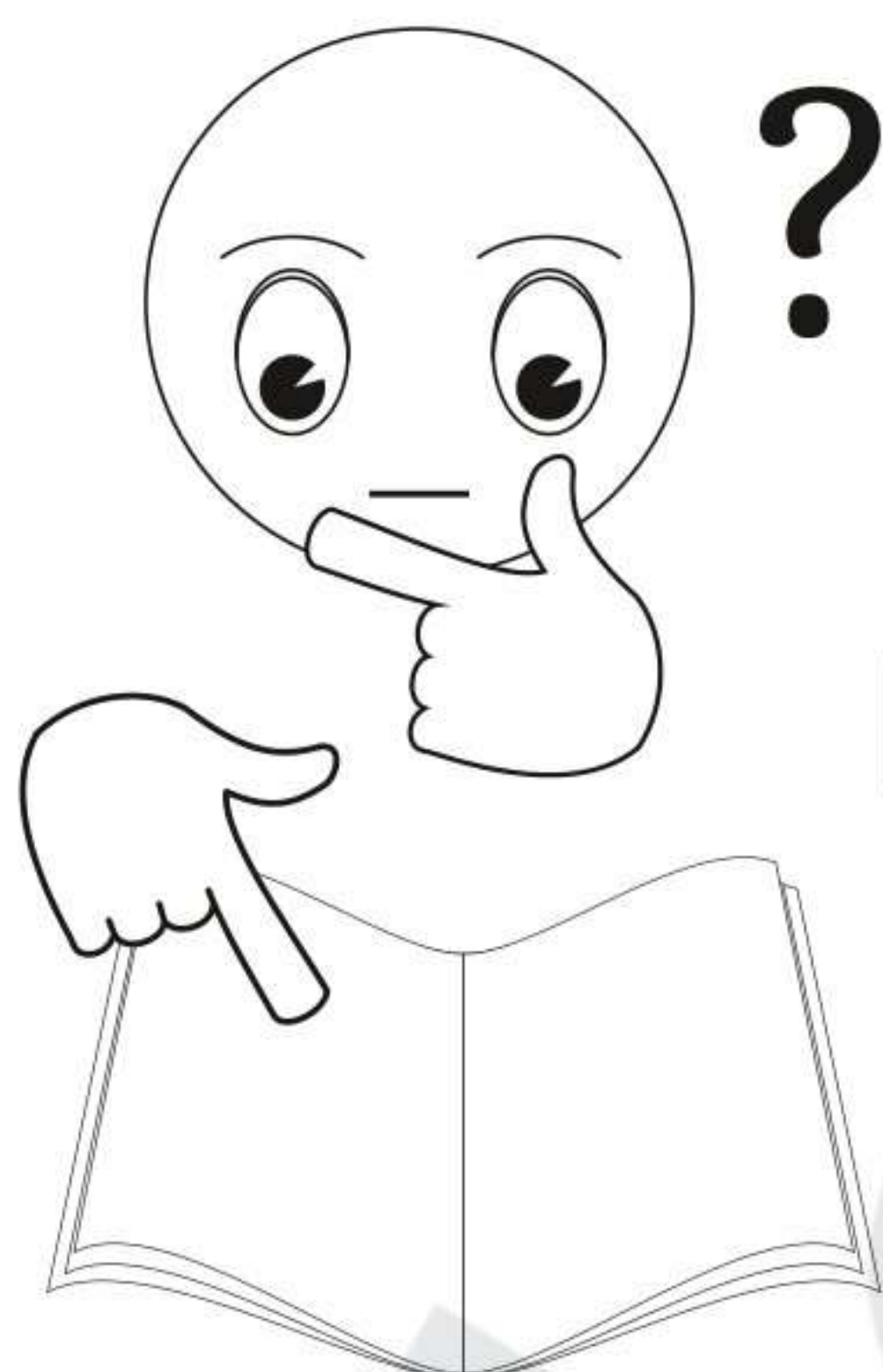
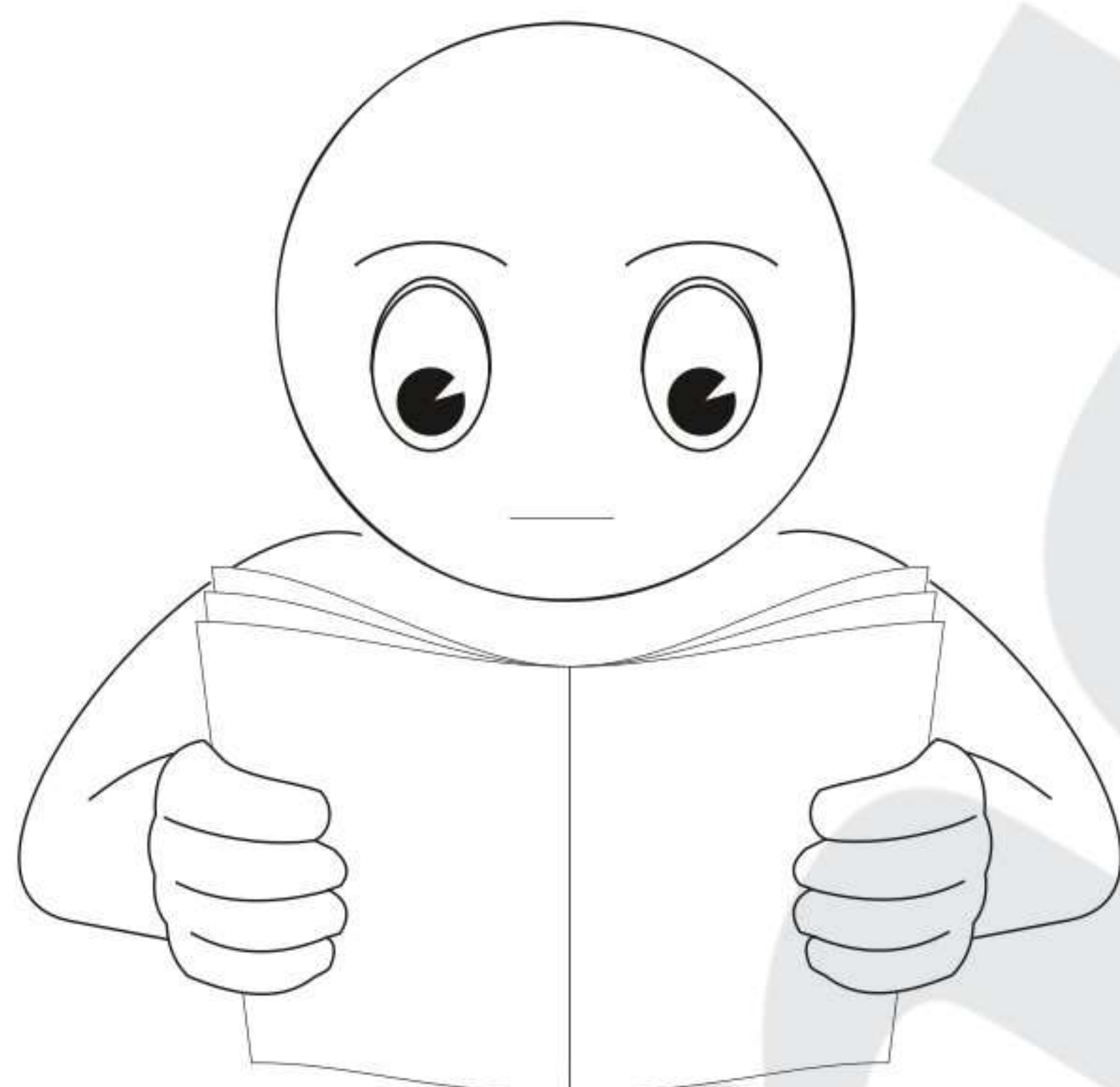
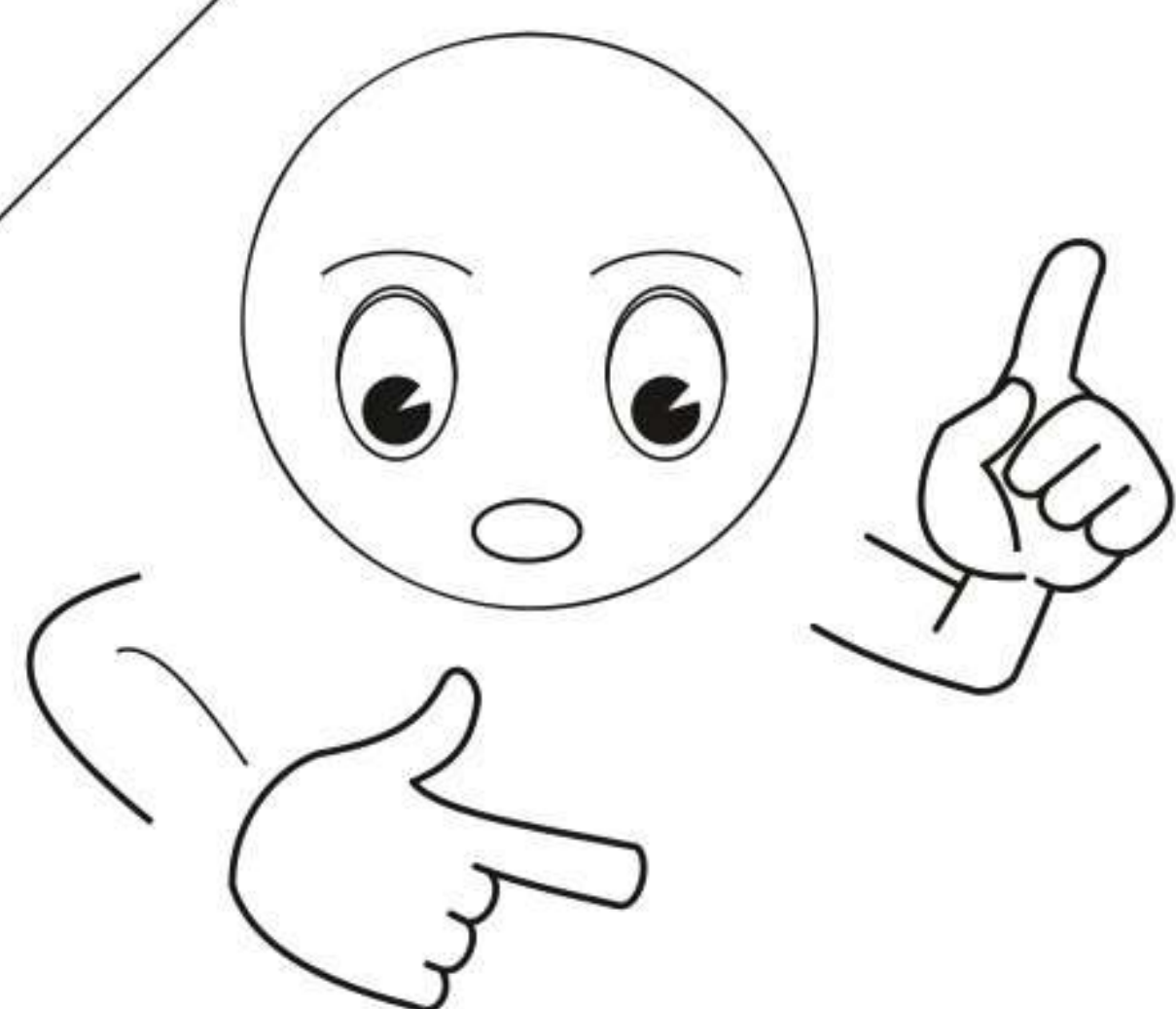

WAŻNE! ZACHOWAĆ DO PÓŹNIEJSZEGO STOSOWANIA: UWAŻNIE PRZECZYTAĆ.

- a. Ostrzeżenie: Bądź świadom ryzyka, jakie stanowi otwarty ogień oraz inne źródła ciepła, takie jak promienniki elektryczne lub gazowe itp. umieszczone w pobliżu łóżka.
- b. Ostrzeżenie: Nie używać łóżka, jeżeli jakkolwiek jego element jest uszkodzony, rozdarty lub brakuje elementu, używać tylko elementów dopuszczonych przez producenta.
- c. Ostrzeżenie: Nie pozostawiać w łóżku czegokolwiek ani nie ustawiać łóżka w pobliżu innego sprzętu, który mógłby stanowić podparcie dla stopy lub spowodować niebezpieczeństwo uduszenia lub powieszenia dziecka, np. przewody, sznurki zasłon/żaluzji.
- d. Ostrzeżenie: Nie używać w łóżku więcej niż jednego materaca.
- e. Zalecana maksymalna grubość materaca 12-15 cm.
- f. Wybrany rozmiar łóżka to wymiar materaca jaki należy zastosować.
- g. Zaleca się aby wszystkie elementy montażowe podczas montażu były dobrze dokręcone oraz regularnie sprawdzane i w razie konieczności dokręcane.

PL

UWAGA: Przed przystąpieniem do montażu prosimy o sprawdzenie wszystkich elementów. Jeśli jakiegokolwiek części są uszkodzone, prosimy nie montować łóżka i natychmiast powiadomić nas o uszkodzonych częściach e-mailem, ze zdjęciami, abyśmy mogli wysłać części zamienne. Po złożeniu łóżka wszelkie reklamacje dotyczące uszkodzonych części nie będą przyjmowane.

IMPORTANT! KEEP FOR FUTURE REFERENCE: READ CAREFULLY.

- EN**
- a. Warning: Be aware of the risks posed by open fire and other heat sources such as electric or gas heaters etc. near the bed.
 - b. Warning: Do not use the bed if any part is damaged, torn or missing, use only the parts approved by the manufacturer.
 - c. Warning: Do not leave anything in the bed or place the bed near any other equipment that could support the foot or pose a risk of suffocation or hanging the child, such as cords, curtain / blind cords.
 - d. Warning: Do not use more than one mattress in the bed.
 - e. Recommended maximum mattress thickness of 12-15 cm.
 - f. The selected bed size is the size of the mattress to be used.
 - g. It is recommended that all assembly elements be tightened well during assembly, regularly checked and tightened if necessary.

Warning: Before starting the assembly, please check all the elements. If any parts are damaged, please do not assemble the bed, and notify us of the damaged parts immediately by email, with photos, so that we can send you replacement parts. Once the bed has been assembled, any complaint regarding damages parts will no longer be accepted.

DÔLEŽITÉ, USCHOVAJTE PRE ĎALŠIE POUŽITIE, ČÍTAJTE POZORNE

- SK**
- a. Upozornenie: Nábytok nesmie byť umiestnený v blízkosti otvoreného ohňa, silného zdroja tepla, elektrických či plynových ohrievačov a pod., u ktorých hrozí vznik požiaru.
 - b. Upozornenie: Nepoužívajte posteľ, ak je niektorá jej časť poškodená, roztrhnutá alebo chýba. Používajte iba diely schválené výrobcom.
 - c. Upozornenie: Nenechávajte v posteli nič ani neumiestňujte posteľ do blízkosti iného vybavenia, ktoré by mohlo slúžiť ako opora pre nohu alebo spôsobiť nebezpečenstvo udusenía či obesenia dieťaťa, napr. káble, laná, šnúry závesov/žalúzií.
 - d. Upozornenie: V posteli nepoužívajte viac ako jeden matrac.
 - e. Odporúčaná maximálna výška matraca je 12–15 cm.
 - f. Zvolený rozmer postele zodpovedá rozmeru matraca, ktorý je potrebné použiť.
 - g. Odporúča sa, aby všetky montážne prvky boli počas montáže pevne dotiahnuté, a aby sa pravidelne kontrolovali a v prípade potreby znovu dotiahli.

POZOR: Pred začatím montáže skontrolujte všetky diely. Ak niektoré časti chýbajú alebo sú poškodené označte ich v montážnom návode, odfotografujte a zašlite spoločne s reklamáciou. Pokiaľ poškodená časť bude na pevno zmontovaná, nebude sa na ňu vzťahovať reklamácia.

DŮLEŽITÉ, USCHOVEJTE PRO POZDĚJŠÍ POUŽITÍ, PŘEČTĚTE SI POZORNĚ

- CZ**
- a. Upozornění: Nábytek nesmí být umístěn v blízkosti otevřeného ohně, silného zdroje tepla, elektrických či plynových topidel a podobných zařízení, u nichž hrozí nebezpečí vzniku požáru.
 - b. Upozornění: Nepoužívejte postel, pokud je některá její část poškozená, roztržená nebo chybí. Používejte pouze díly schválené výrobcem.
 - c. Upozornění: Nenechávejte v posteli žádné předměty a neumísťujte postel do blízkosti jiného vybavení, které by mohlo sloužit jako opora pro nohu nebo způsobit nebezpečí udušení či uškrcení dítěte, např. kabely, lana, šňůry záclon/žaluzií.
 - d. Upozornění: V posteli nepoužívejte více než jednu matraci.
 - e. Doporučená maximální výška matrace je 12–15 cm.
 - f. Zvolená velikost postele odpovídá velikosti matrace, kterou je třeba použít.
 - g. Doporučuje se, aby byly všechny montážní prvky během montáže pevně utaženy a aby byly pravidelně kontrolovány a v případě potřeby znovu utaženy.

POZOR: Před zahájením montáže zkontrolujte všechny díly. Pokud některé díly chybí nebo jsou poškozené, označte je v montážním návodu, vyfotografujte je a zašlete spolu s reklamací. Pokud bude poškozený díl pevně namontován, nebude se na něj vztahovat reklamáce.

FONTOS! ŐRIZZE MEG KÉSŐBBI HASZNÁLATRA, FIGYELMESEN OLVASSA EL

- a. Figyelmeztetés: A bűrtort ne helyezze nyílt láng, erős hőforrás, illetve elektromos vagy gázüzemű fűtőberendezések közelébe, mivel ezek tűzveszélyt jelenthetnek.
- b. Figyelmeztetés: Ne használja az ágyat, ha annak bármely része sérült, szakadt vagy hiányzik. Csak a gyártó által jóváhagyott alkatrészeket használja.
- c. Figyelmeztetés: Ne hagyjon semmit az ágyban, és ne helyezze az ágyat olyan dolgok közelébe, amelyeknek köszönhetően gyermeke kimászhat az ágyból, vagy a fulladását okozhatnák, illetve felakaszthatná magát rajta, pl. kábelek, kötelek, függöny-/redőnyzsinórok.
- d. Figyelmeztetés: Ne használjon egynél több matracot az ágyban.
- e. Az ajánlott maximális matracvastagság 12–15 cm.
- f. A kiválasztott ágy méretének meg kell egyeznie a használni kívánt matrac méretével.
- g. Az összeszerelés során minden rögzítőelemet megfelelően húzzon meg, és azokat rendszeresen ellenőrizze, szükség esetén húzza utána.

HU

FIGYELEM: Az összeszerelés megkezdése előtt ellenőrizze az összes alkatrészt. Ha bármely alkatrész hiányzik vagy sérült, jelölje meg a szerelési útmutatóban, készítsen róla fényképet, és adjon le róla reklamációt a honlapunkon keresztül. Amennyiben a sérült alkatrész véglegesen beépítésre kerül, a reklamációt nem áll módunkban elfogadni.

IMPORTANTE! CONSERVAR PARA FUTURAS CONSULTAS: EER CUIDADOSAMENTE.

- a. Advertencia: tenga en cuenta los riesgos que plantean las llamas abiertas y otras fuentes de calor, com calentadores eléctricos o de gas, etc., cerca de la cama.
- b. Advertencia: No use la cama si alguna parte está dañada, rota o falta, use solo las partes aprobadas por el fabricante.
- c. Advertencia: No deje nada en la cama ni coloque la cama cerca de ningún otro equipo que pueda sostener el pie o suponga un riesgo de asfixia o colgar al niño, como cuerdas, cuerdas de cortinas / persianas.
- d. Advertencia: No use más de un colchón en la cama.
- e. Grosor máximo recomendado del colchón de 12–15 cm.
- f. El tamaño de cama seleccionado es el tamaño del colchón que se utilizará.
- g. Se recomienda que todos los elementos de montaje estén bien apretados durante el montaje, revisados regularmente y apretados si es necesario.

ES





ATENCIÓN: Antes de comenzar el montaje, compruebe todas las piezas. Si alguna pieza está dañada no monte la cama y notifíquenoslo inmediatamente por correo electrónico para que podamos enviarle piezas de recambio. Una vez montada la cama, no se aceptan reclamaciones.



WICHTIG! FÜR SPÄTERES NACHSCHLAGEN AUFBEWAHREN: SORGFÄLTIG LESEN.

- a. Warnung: Seien Sie sich der Risiken bewusst, die durch offenes Feuer und andere Wärmequellen wie Elektro- oder Gasheizungen usw. in der Nähe des Bettes entstehen.
- b. Warnung: Verwenden Sie das Bett nicht, wenn Teile beschädigt, gerissen oder fehlen, verwenden Sie nur die vom Hersteller zugelassenen Teile.
- c. Warnung: Lassen Sie nichts im Bett liegen und stellen Sie das Bett nicht in die Nähe anderer Geräte, die den Fuß stützen oder eine Erstickungsgefahr oder das Aufhängen des Kindes darstellen könnten, wie z.B. Drähte, Gardinen-/Rolloschnüre.
- d. Warnung: Verwenden Sie nicht mehr als eine Matratze im Bett.
- e. Empfohlene maximale Matratzendicke von 12–15 cm.
- f. Die gewählte Bettgröße ist die Größe der zu verwendenden Matratze.
- g. Es wird empfohlen, alle Montageelemente während der Montage gut anzuziehen, regelmäßig zu kontrollieren und ggf. nachzuziehen.

DE

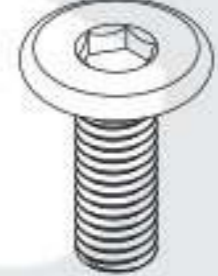
ACHTUNG: Bitte prüfen Sie vor dem Aufbau ob Sie alle Elemente erhalten haben. Sollten einige Teile beschädigt sein, bitten wir Sie das Bett vorerst nicht aufzubauen und uns die Schäden schriftlich zu melden. Wir werden diese schnellstens ersetzen. Sollte das Bett bereits aufgebaut worden sein, so kann die Reklamation nicht akzeptiert werden.

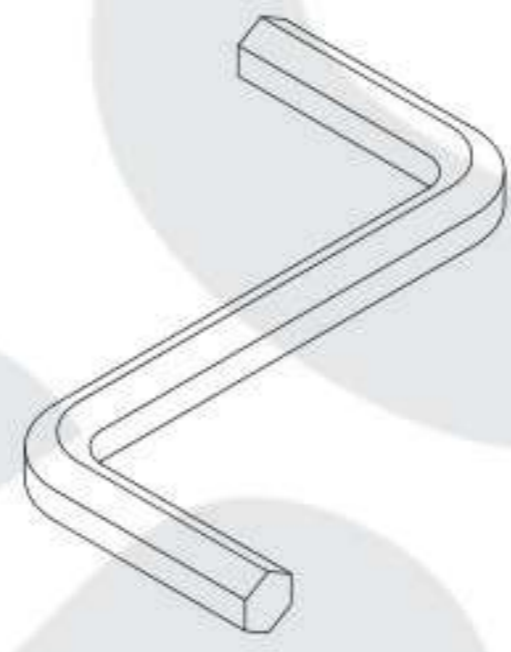
120	100	080	035	017
 M6x120	 M6x100	 M6x80	 M6x35	 M6x16
2-4x	9x	16x	4x	2x

001	002	006
 2x		 4x

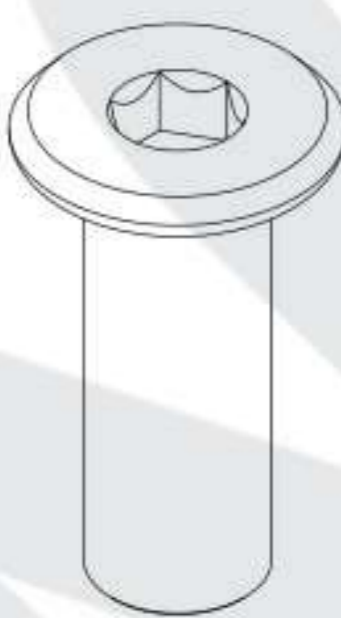
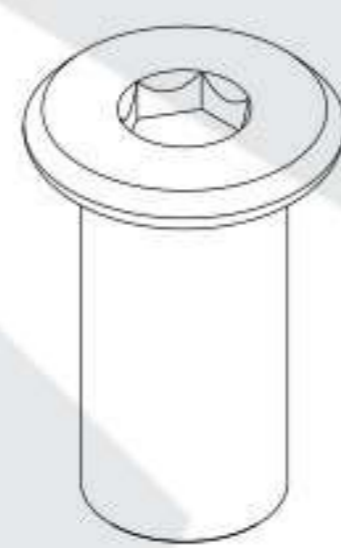
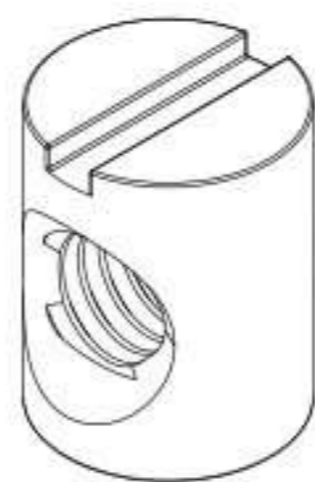
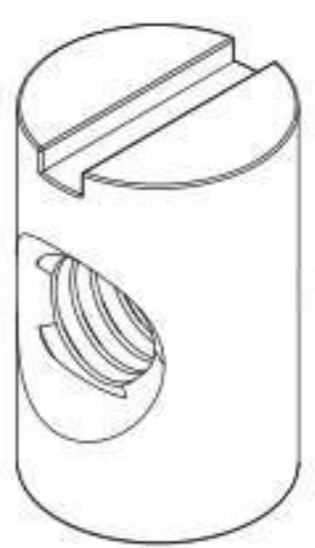
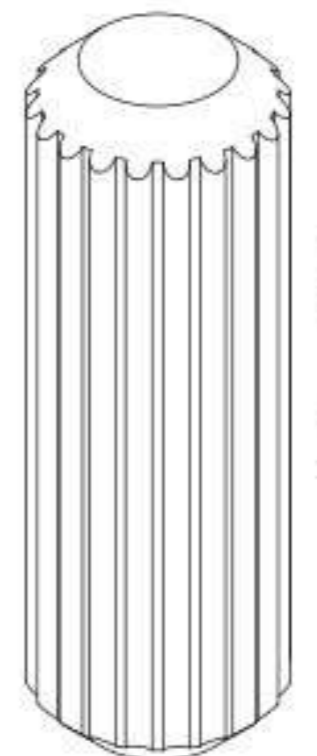
025	018	013	015	010
				 ø10x30
6-8x	2x	24x	1x	20x

6

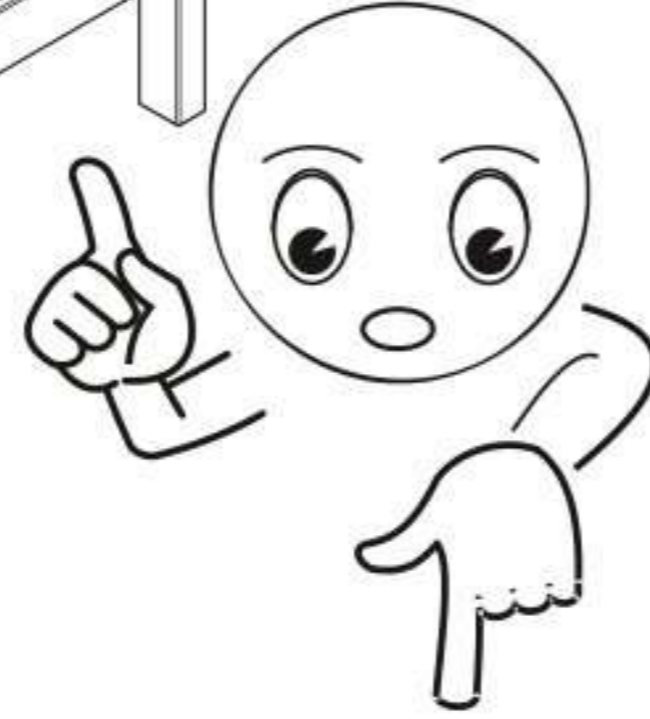
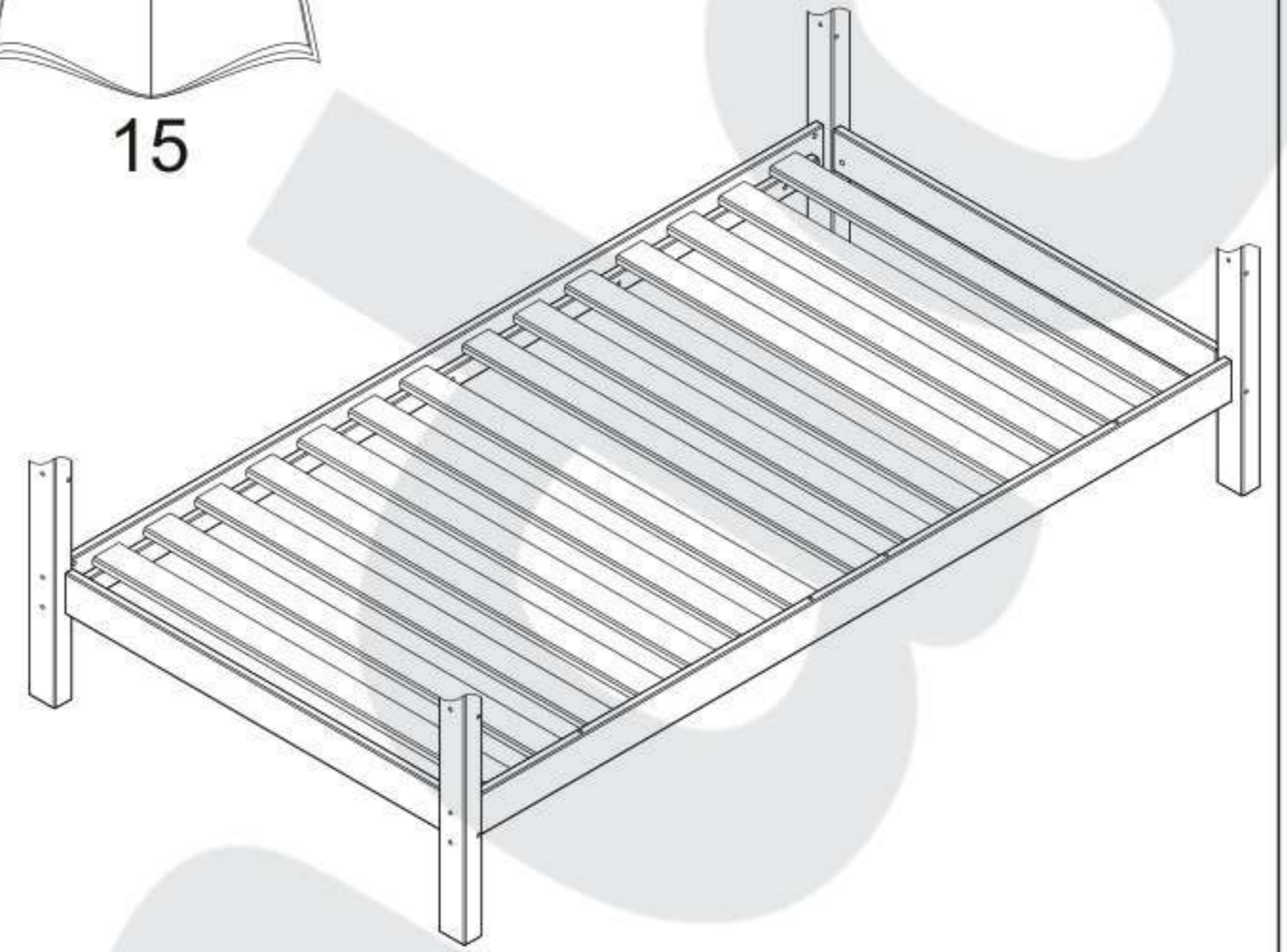
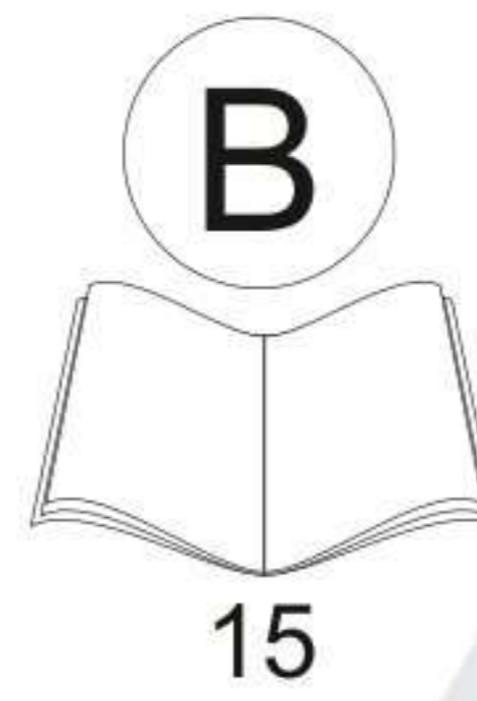
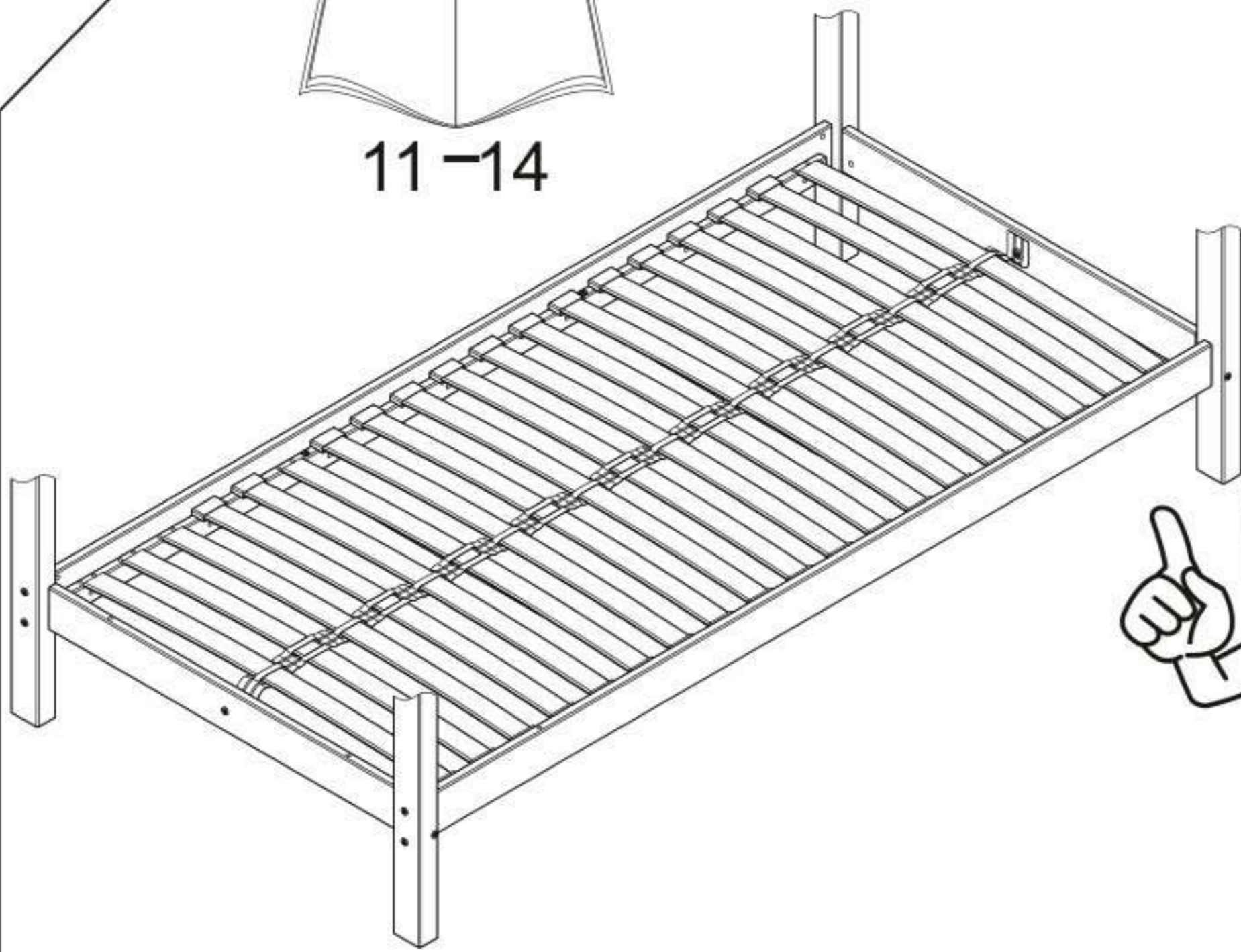
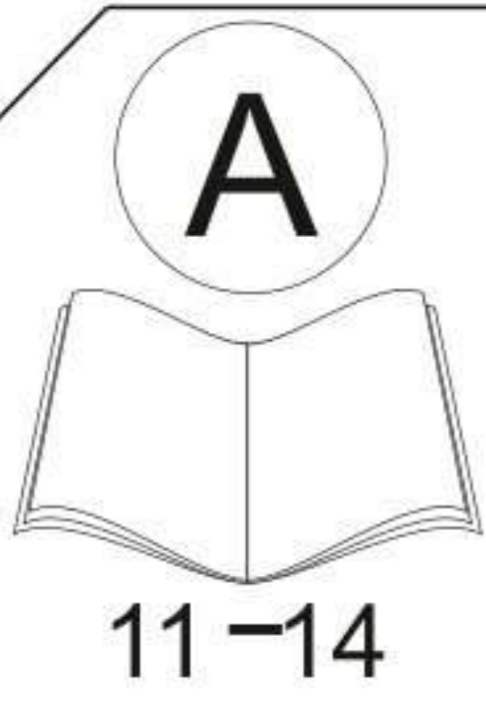

120cm-140cm

035	025	017	018
4x	4x	2x	2x

	140cm	160cm	180cm	190cm	200cm
--	-------	-------	-------	-------	-------

055		28x	32x	36x	38x	40x
-----	--	------------	------------	------------	------------	------------

095		14x	16x	18x	19x	20x
-----	--	------------	------------	------------	------------	------------

092		×	1x	1x	1x	1x
-----	--	---	-----------	-----------	-----------	-----------

091		×	2x	2x	2x	2x
-----	--	---	-----------	-----------	-----------	-----------

	(60cm)	70cm-100cm
--	-------------------	-------------------

	190cm	200cm	
098		14x	15x
033		56x	60x

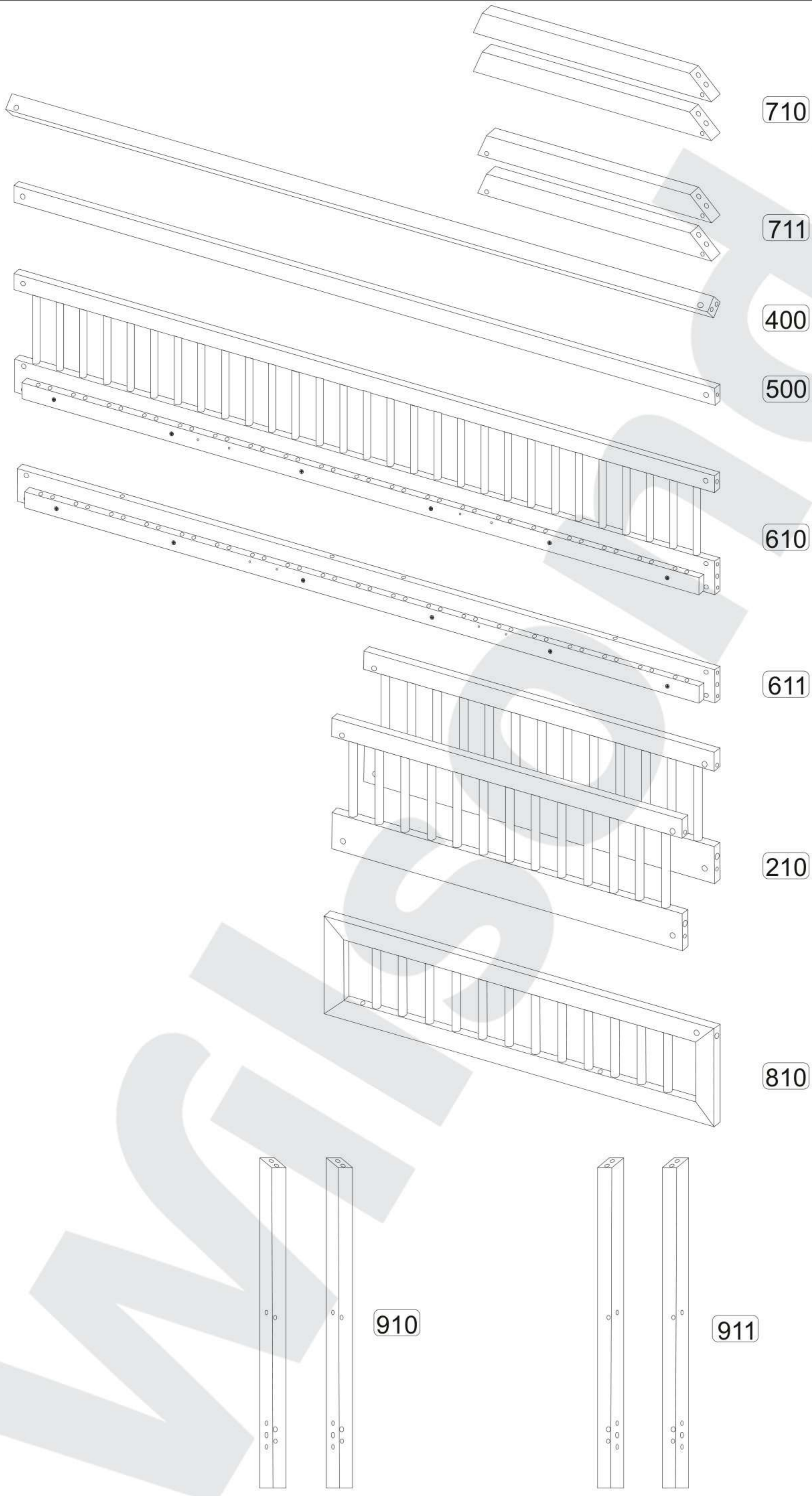

8



4x

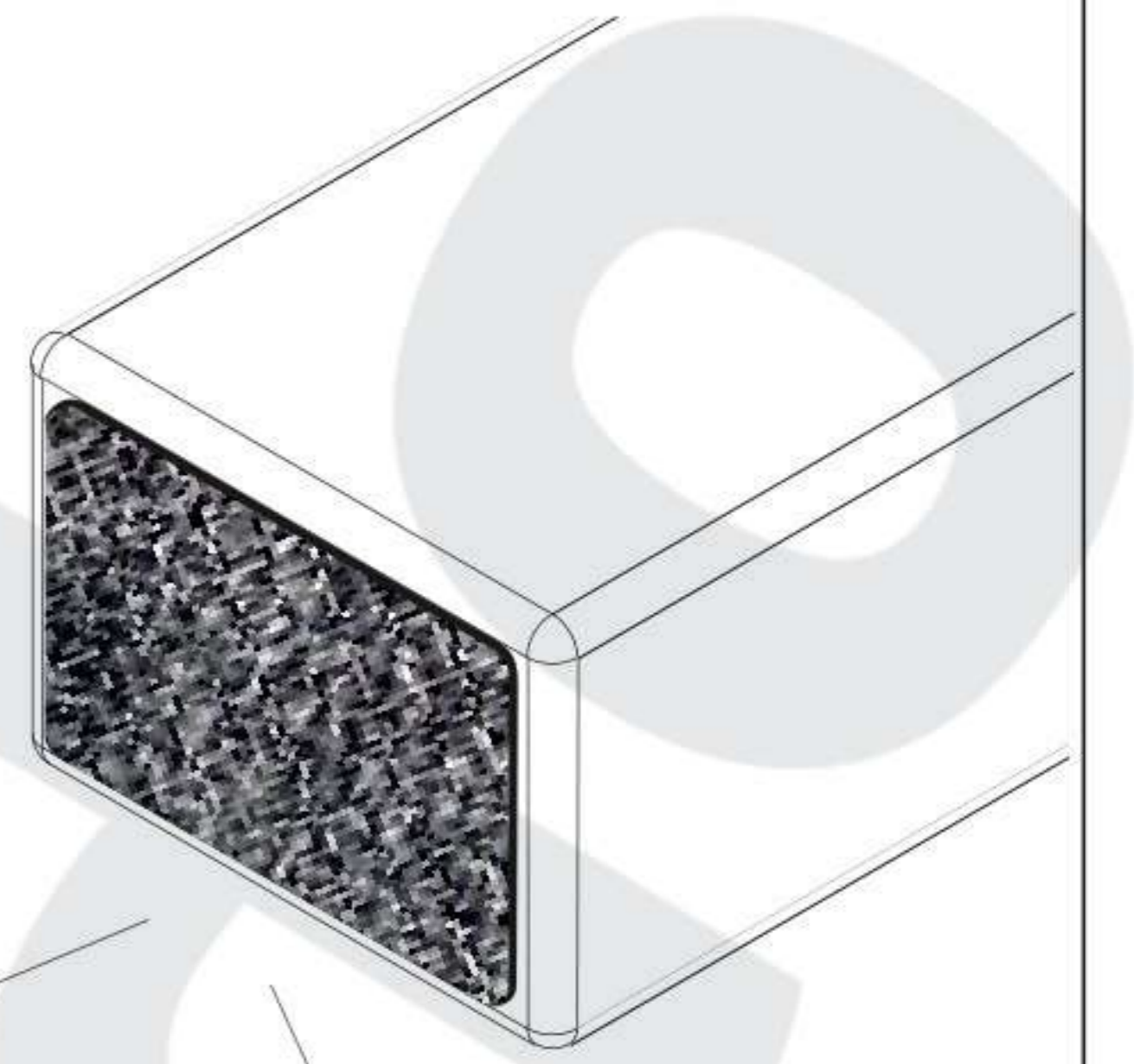

001



010

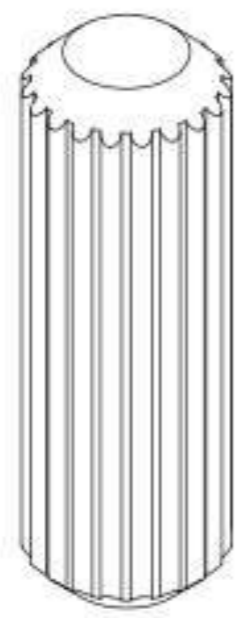

20x

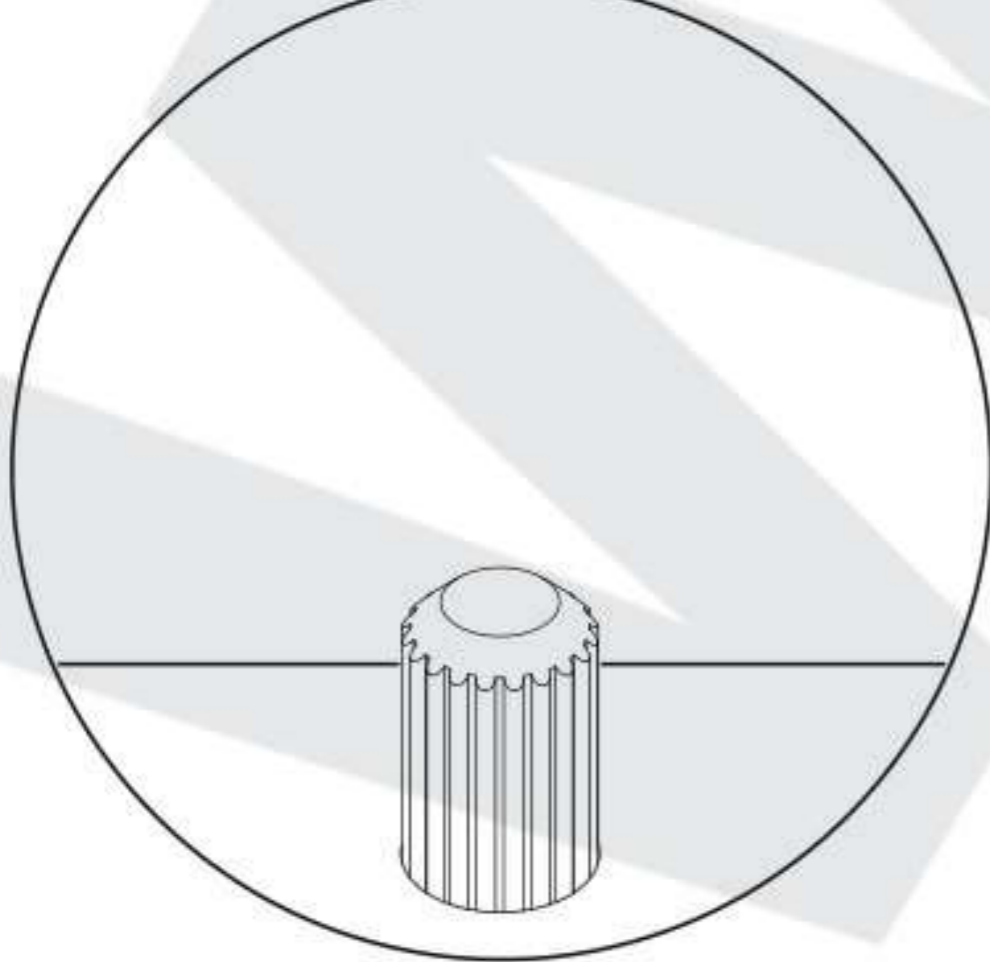
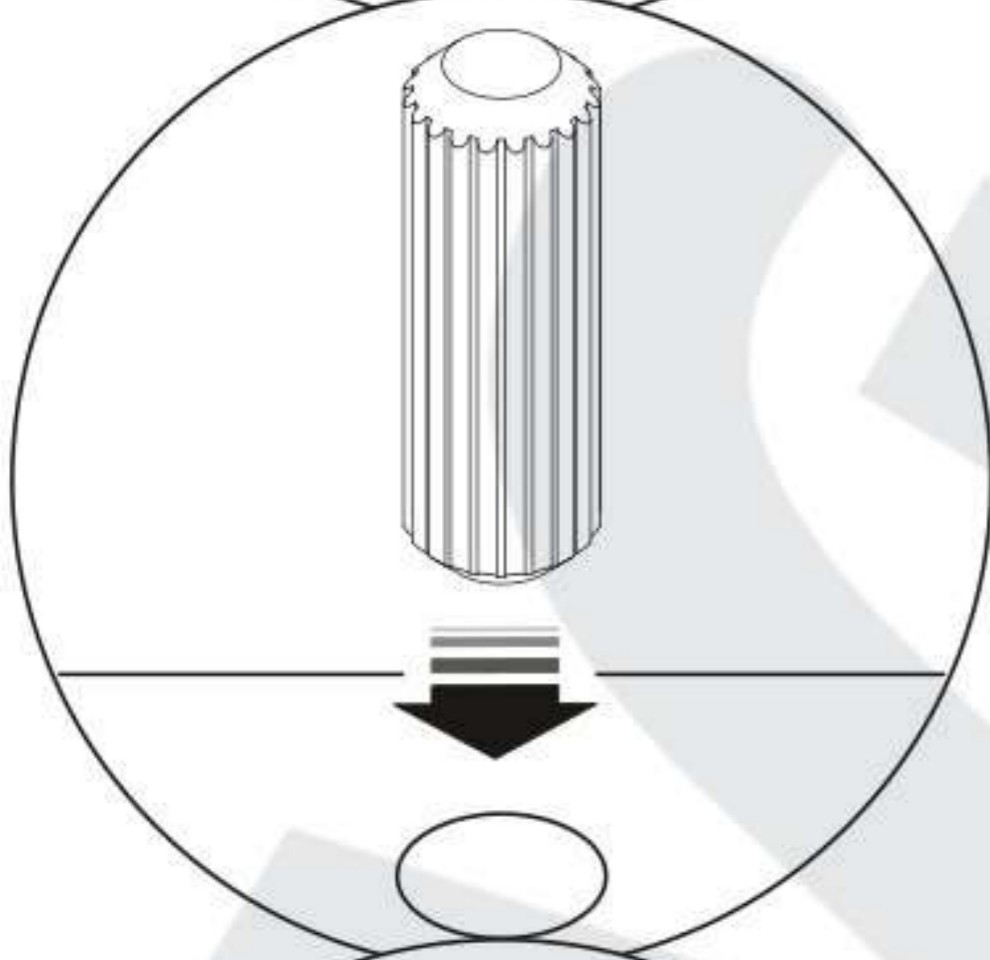
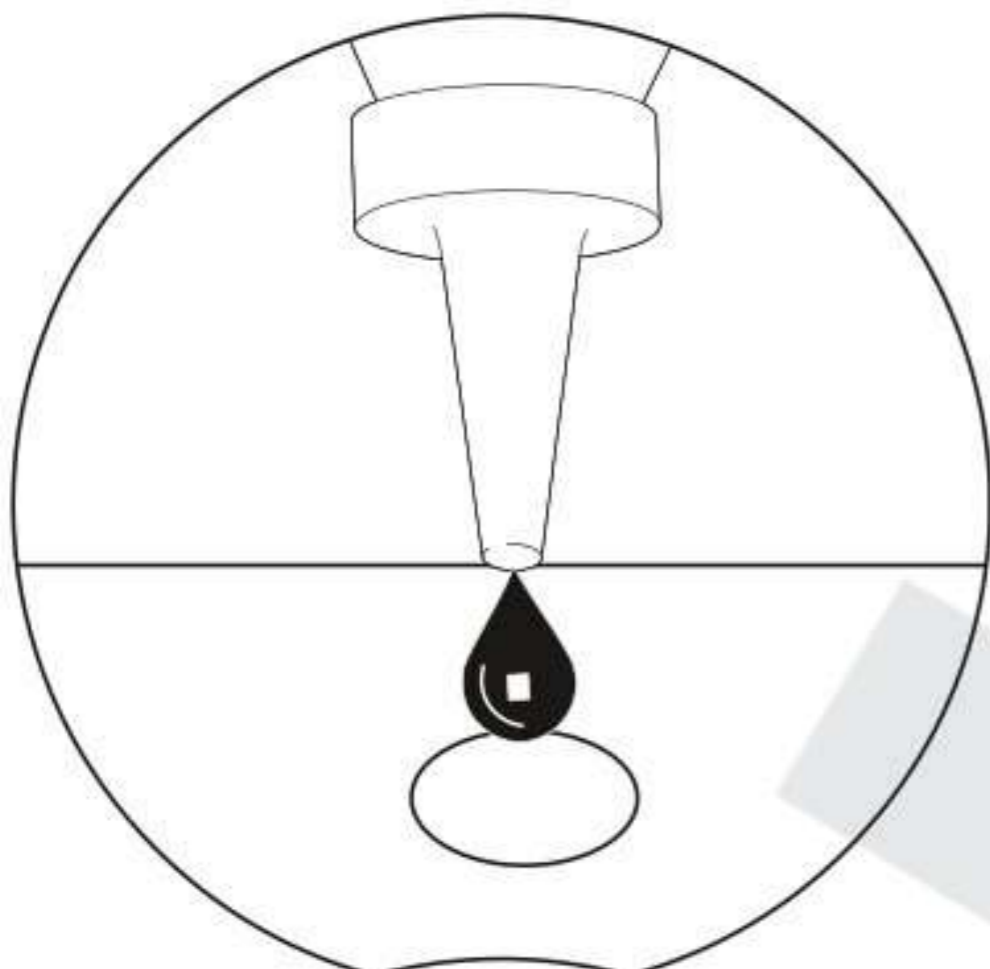

911



911

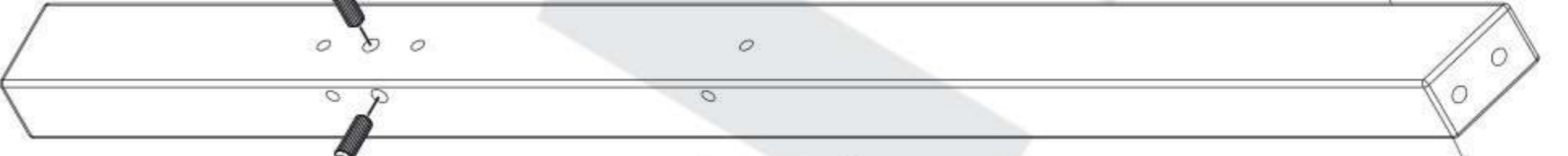

910



910

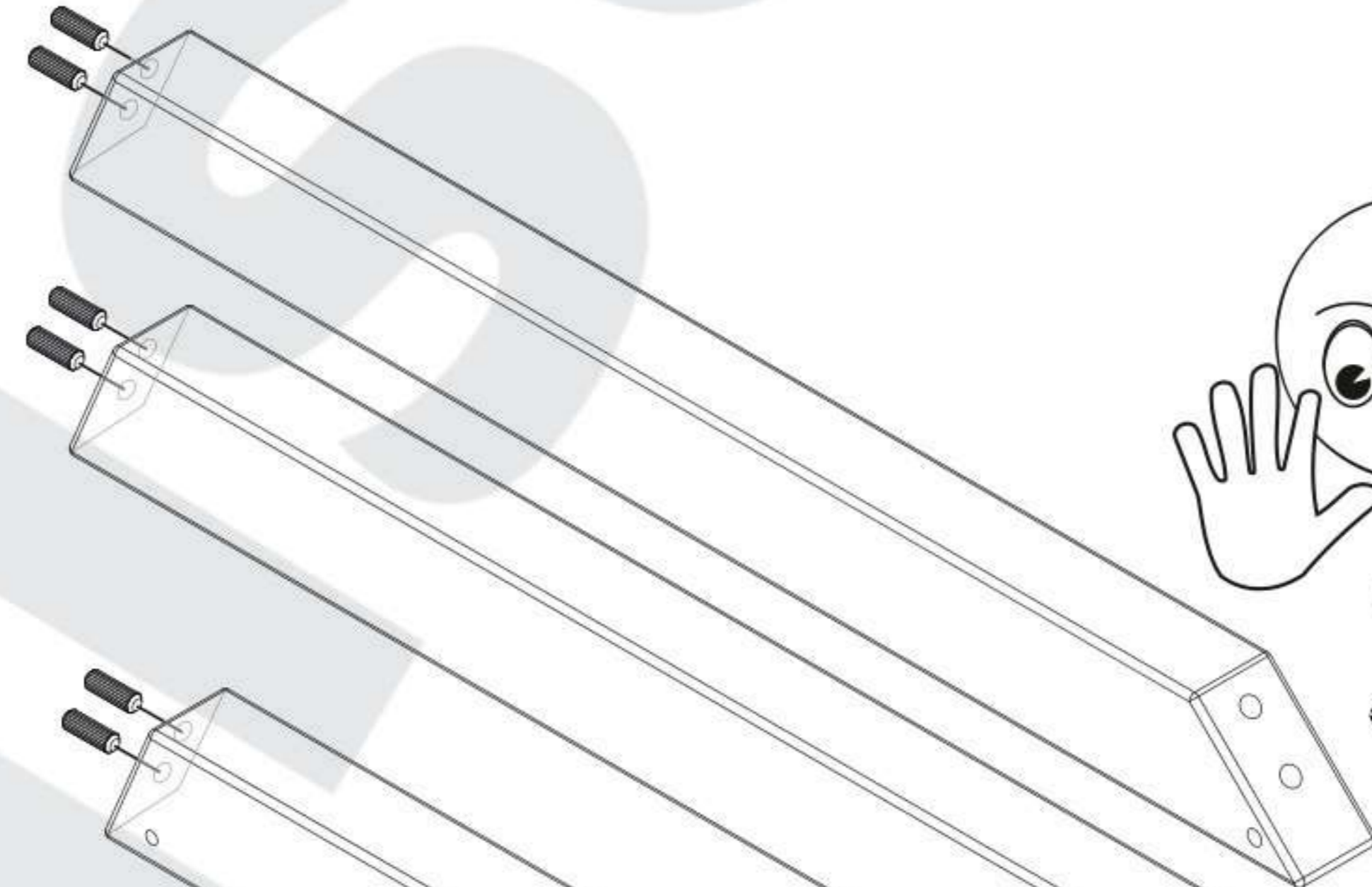





710

710

711



711

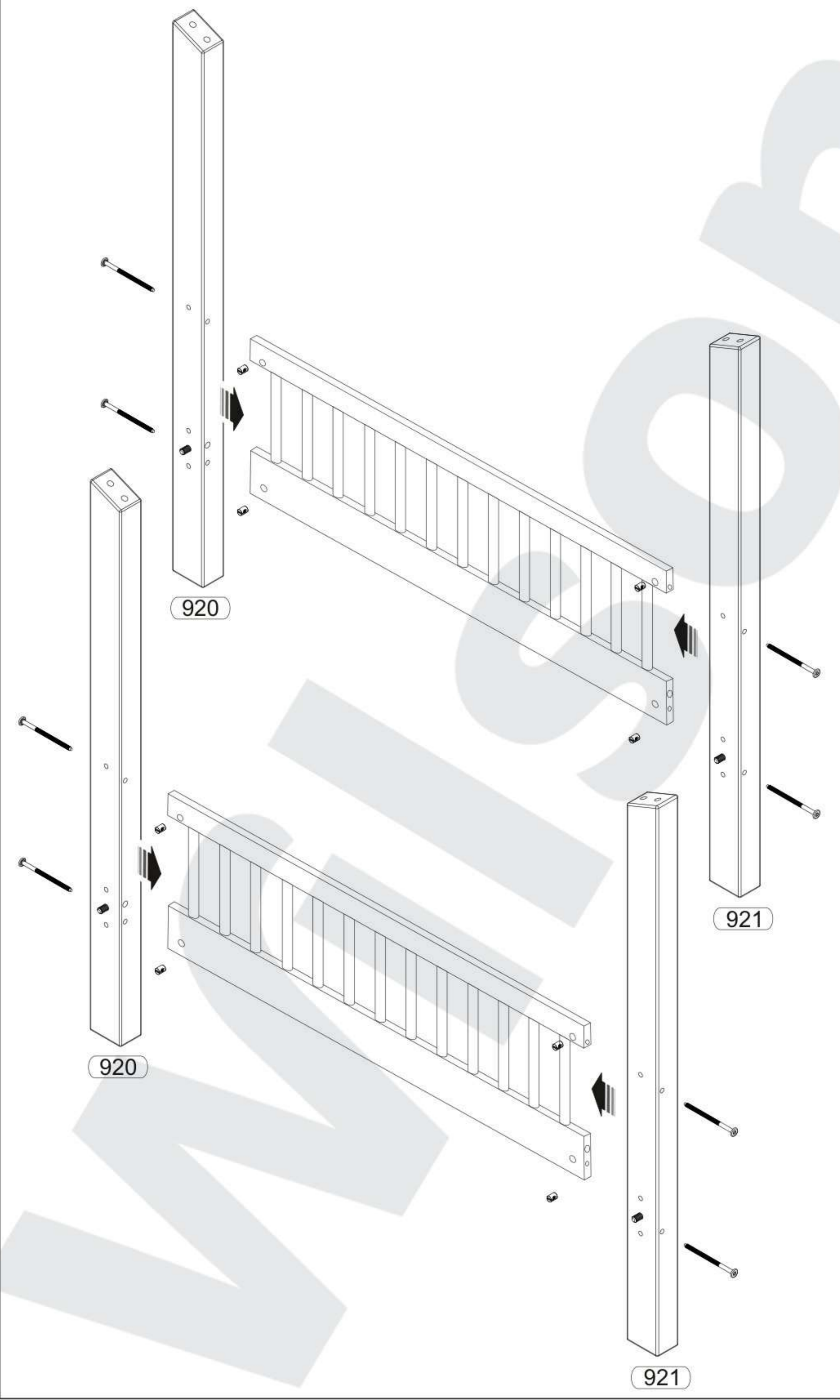
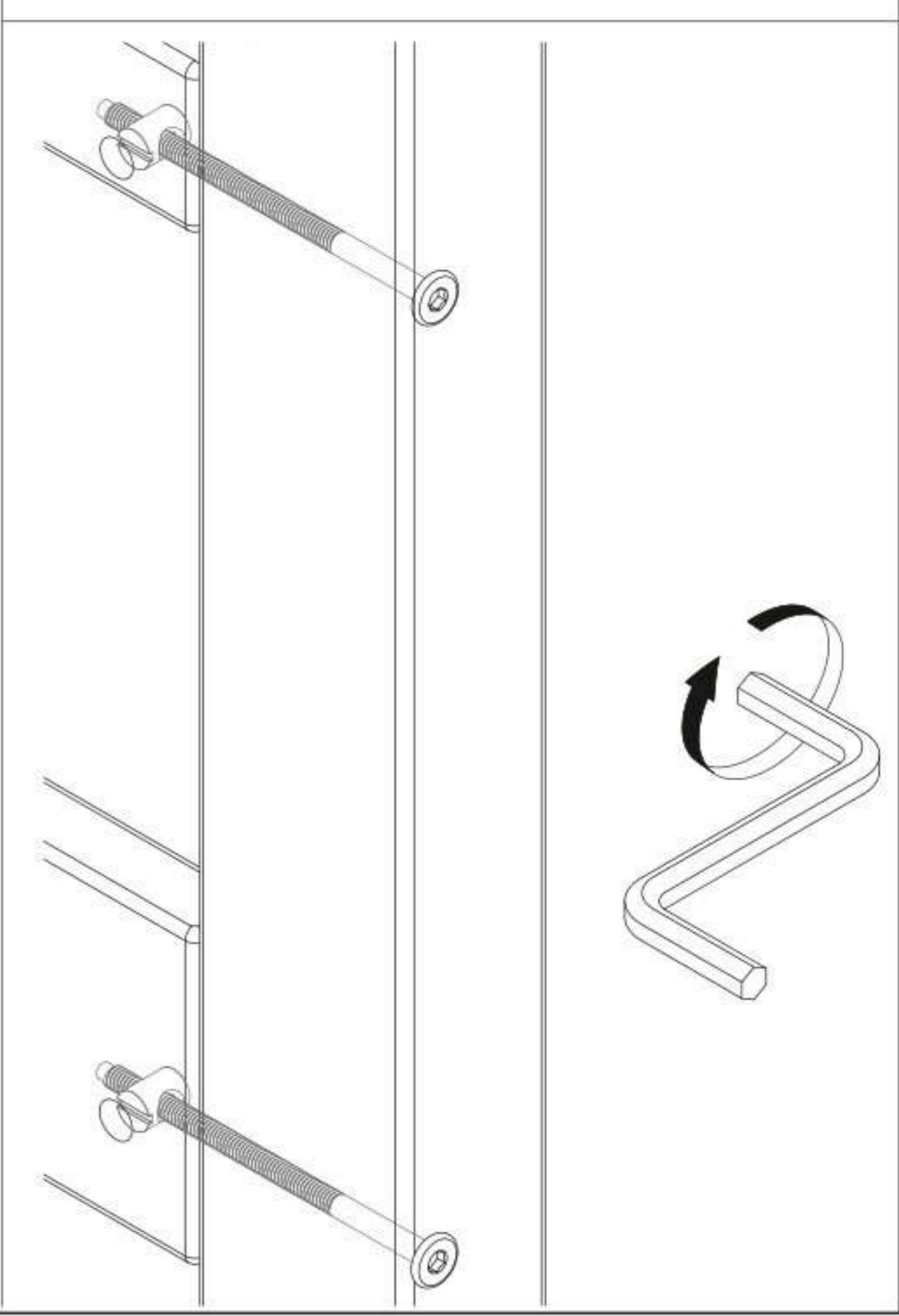
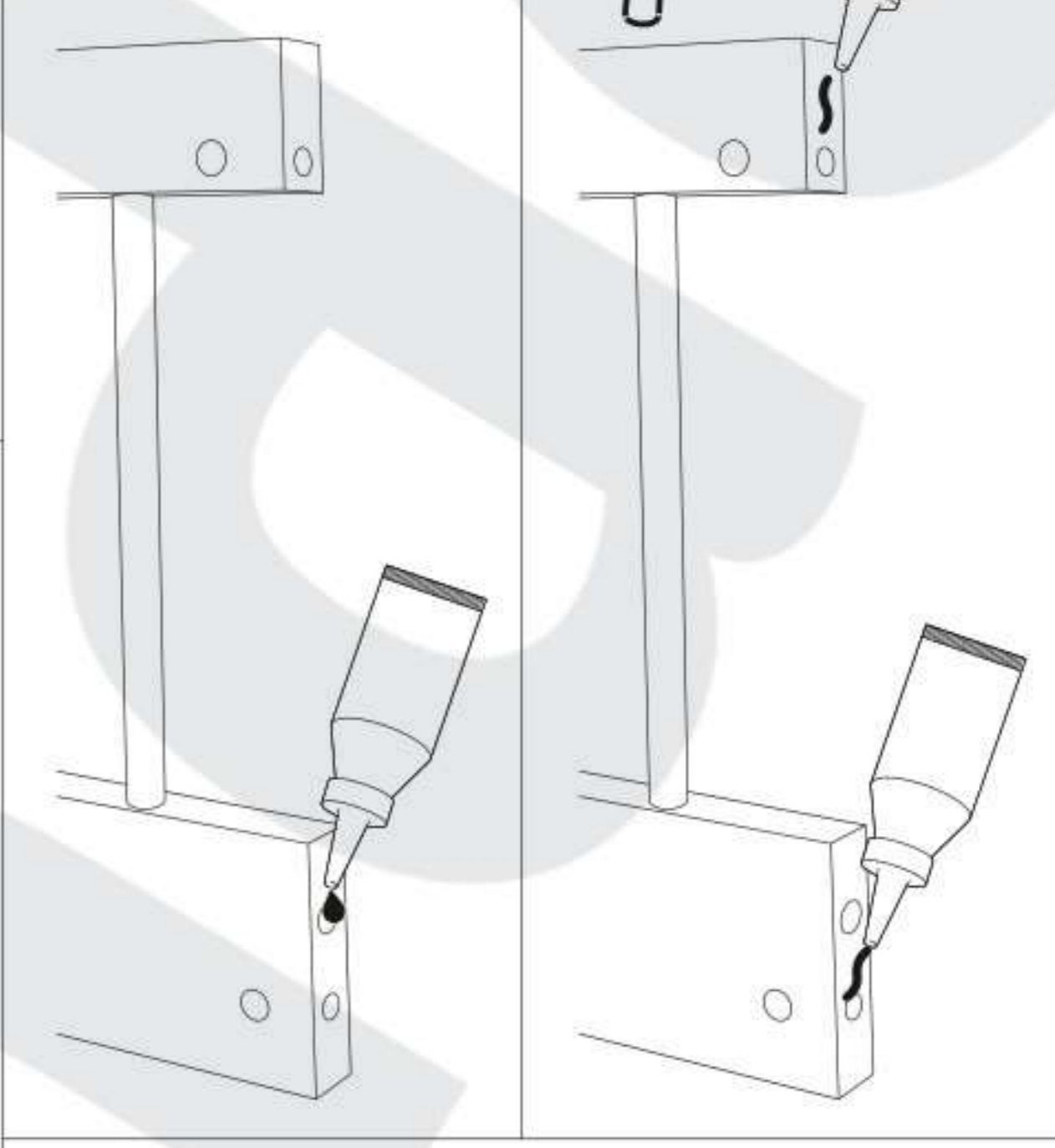

013	100	001	002
			
8x	8x		

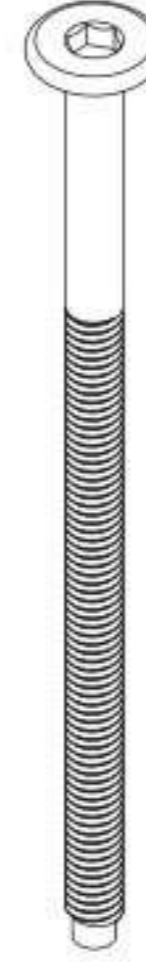

10

013	080	001	002
			
10x	10x		

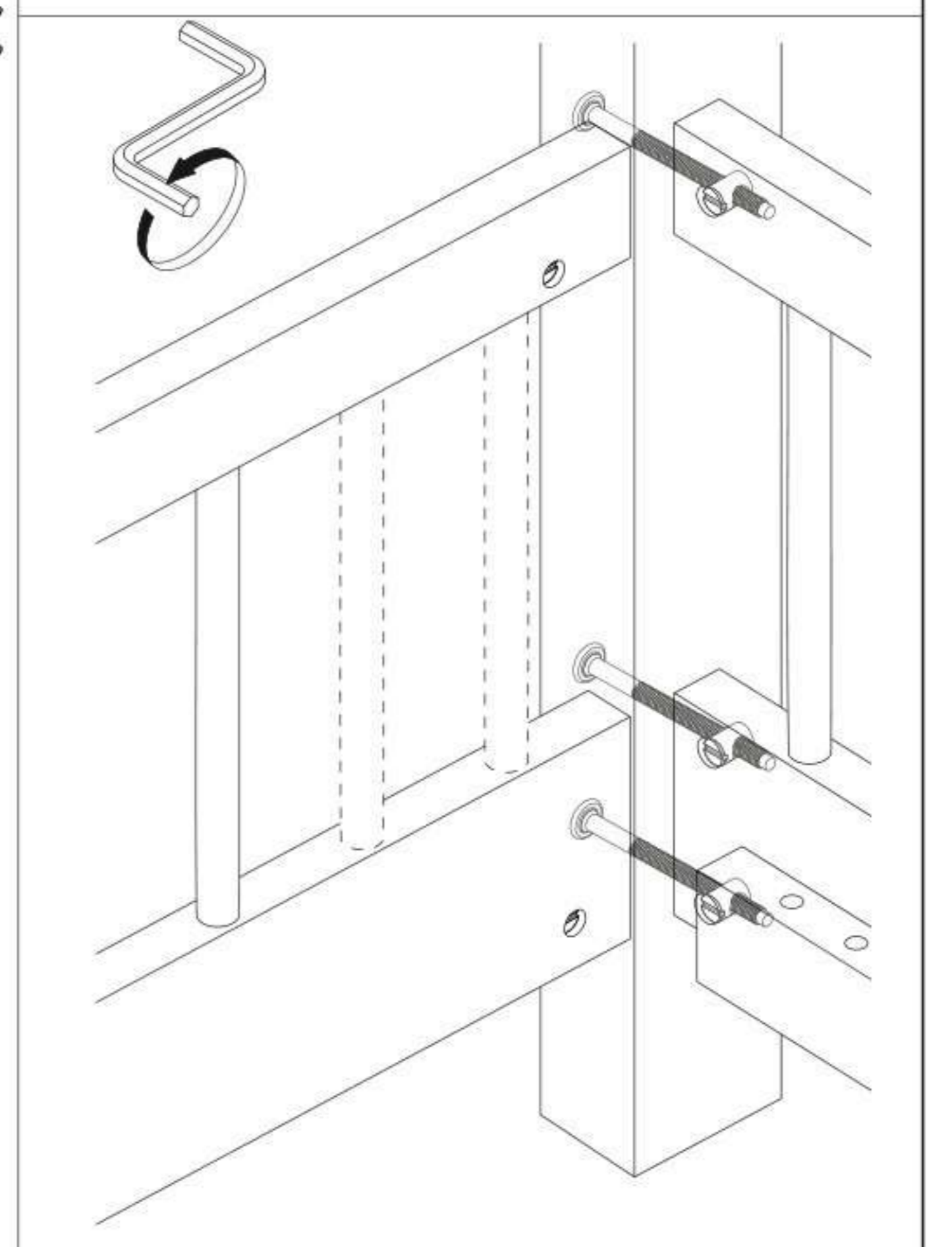
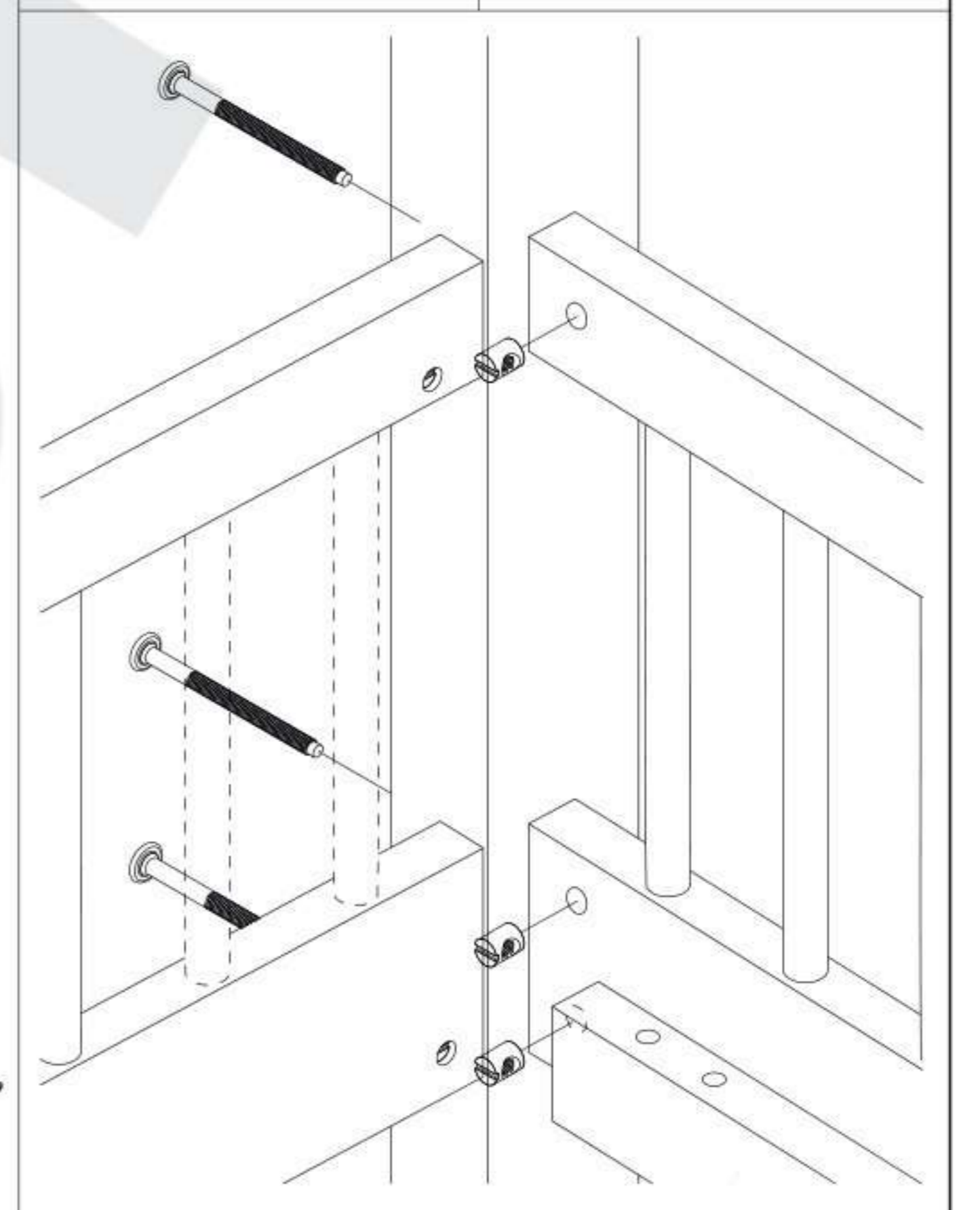
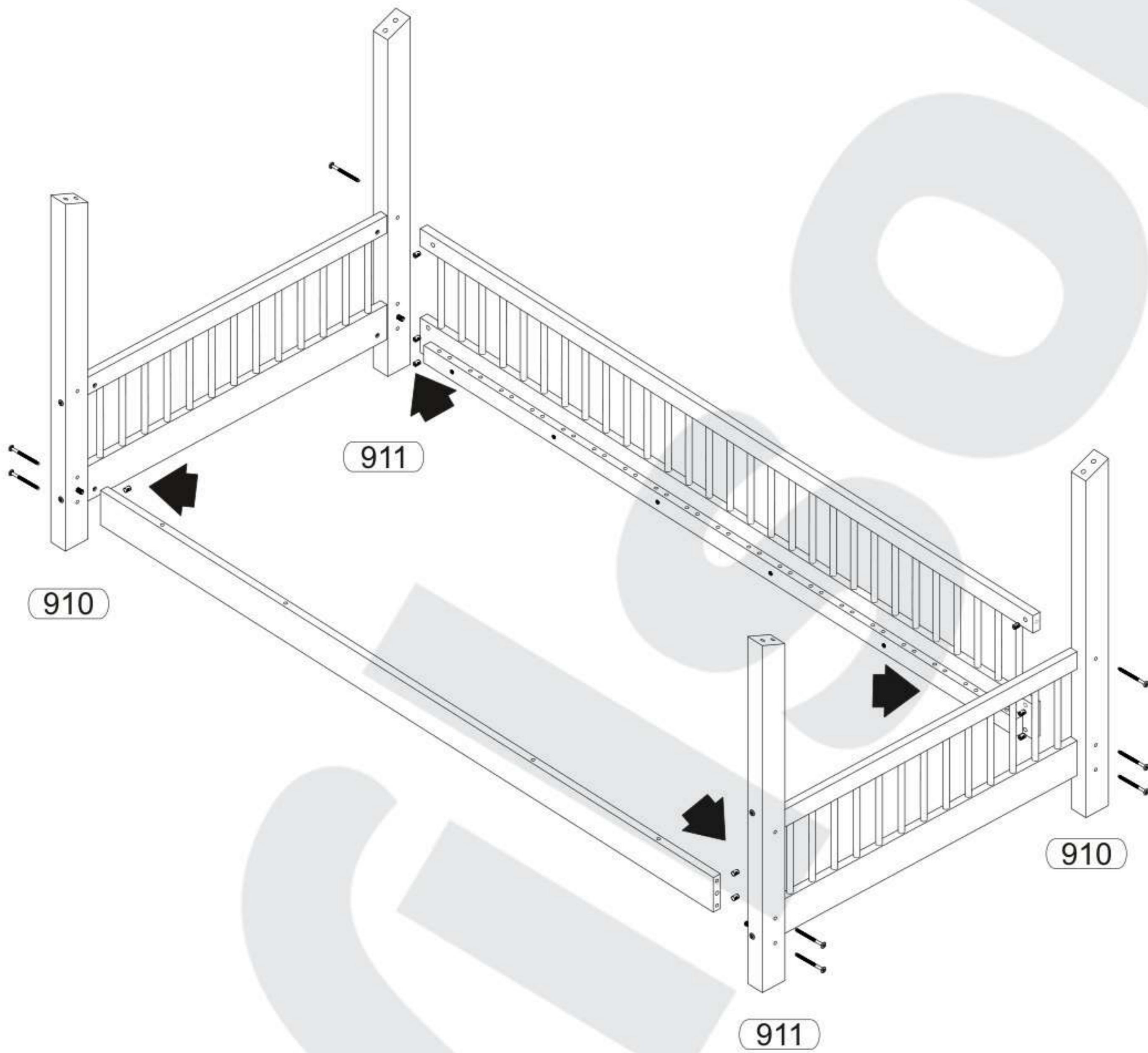
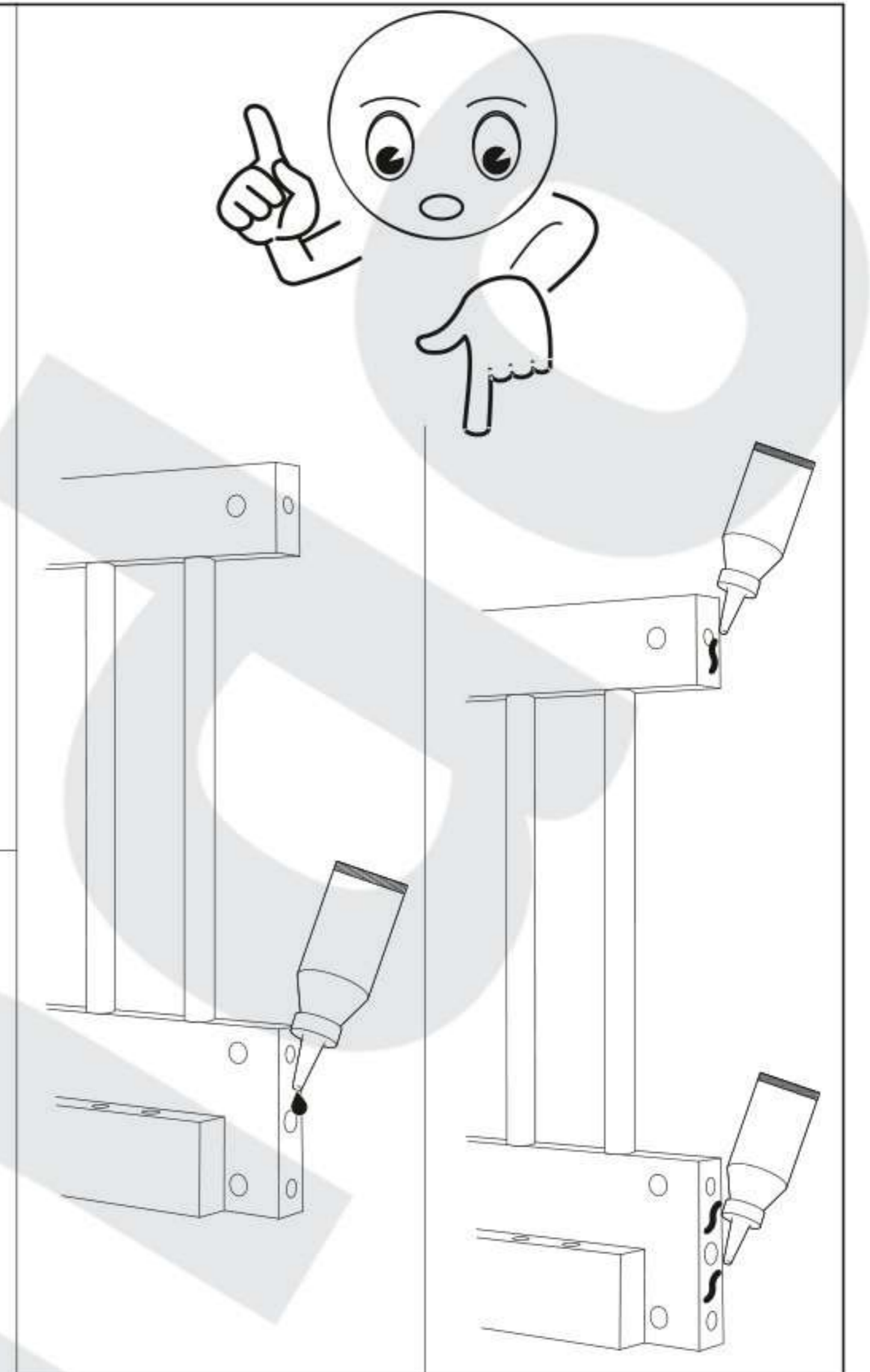

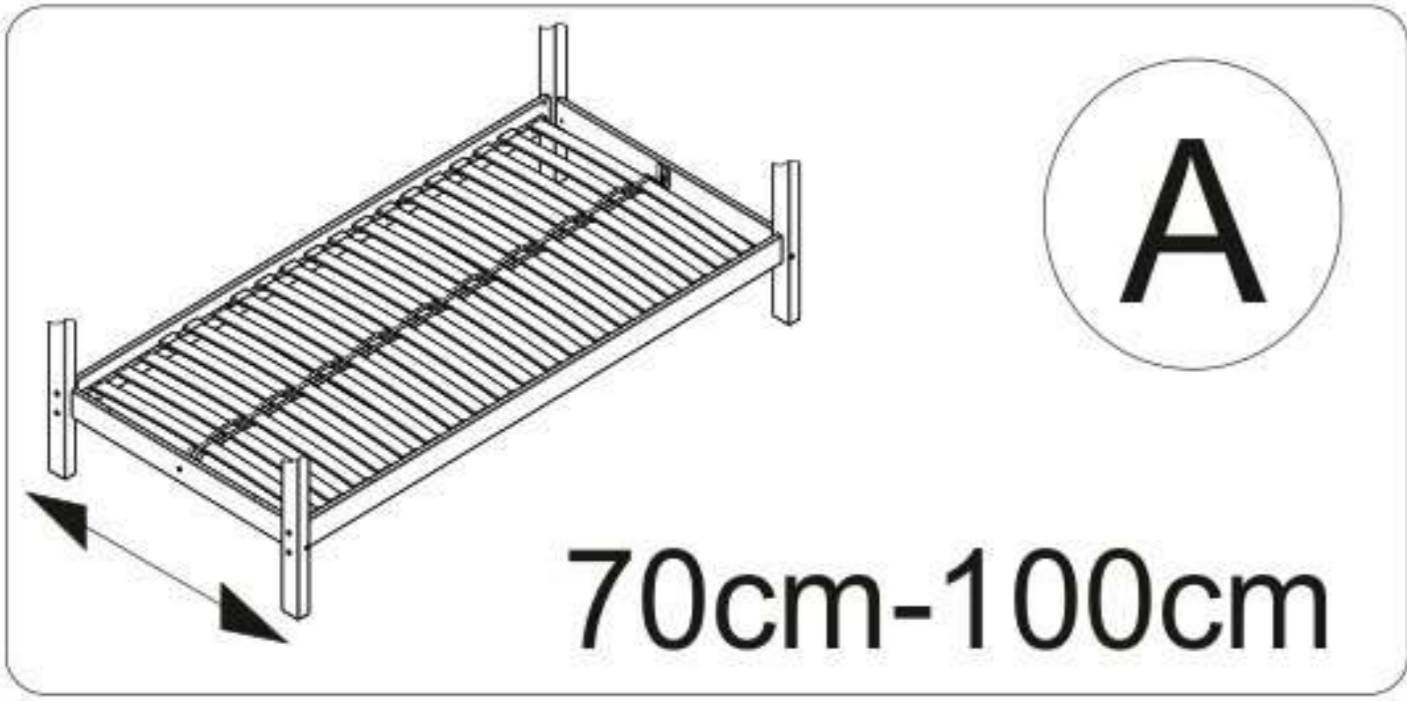

035	025	002	091
4x	4x		2x

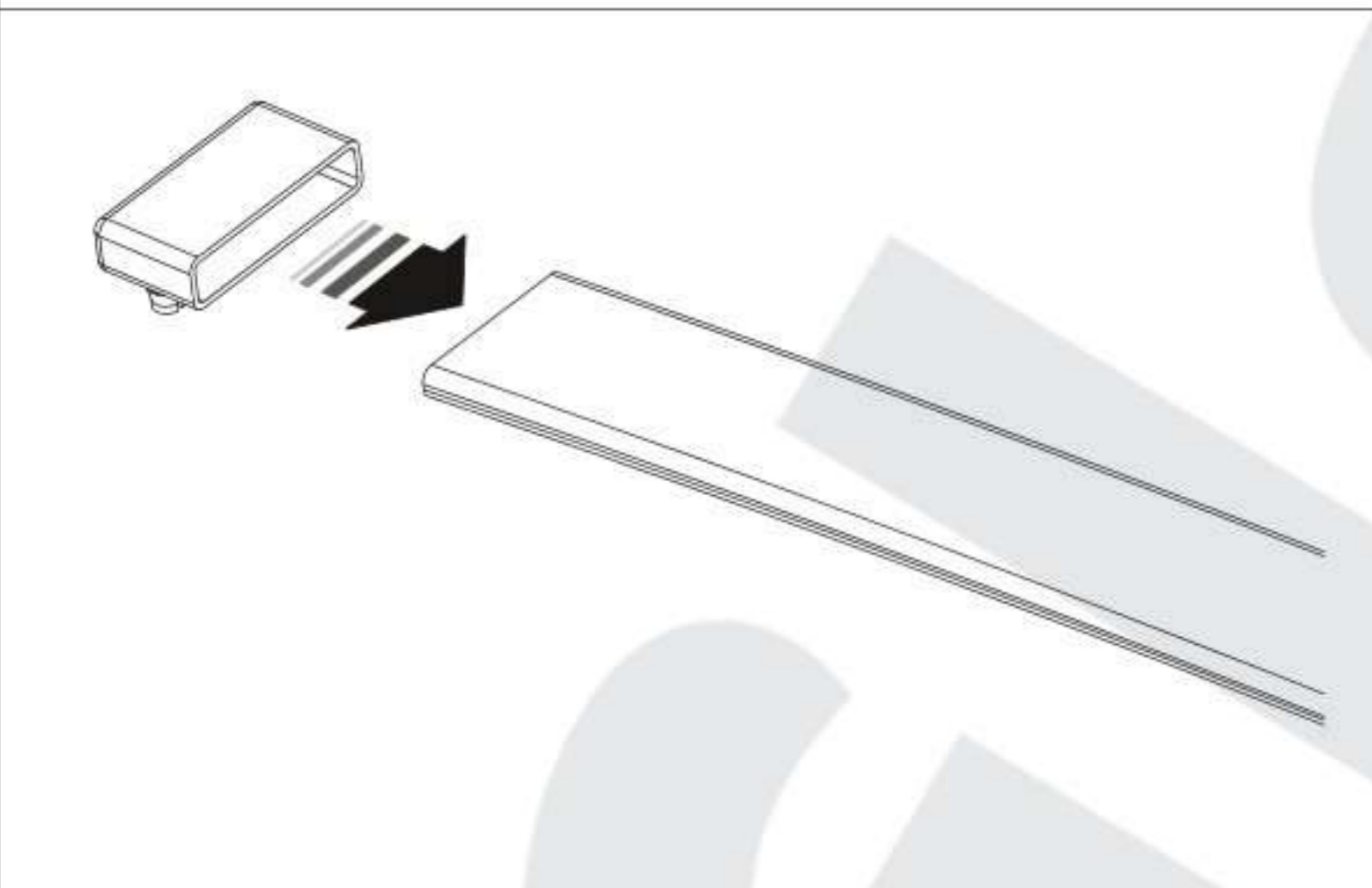
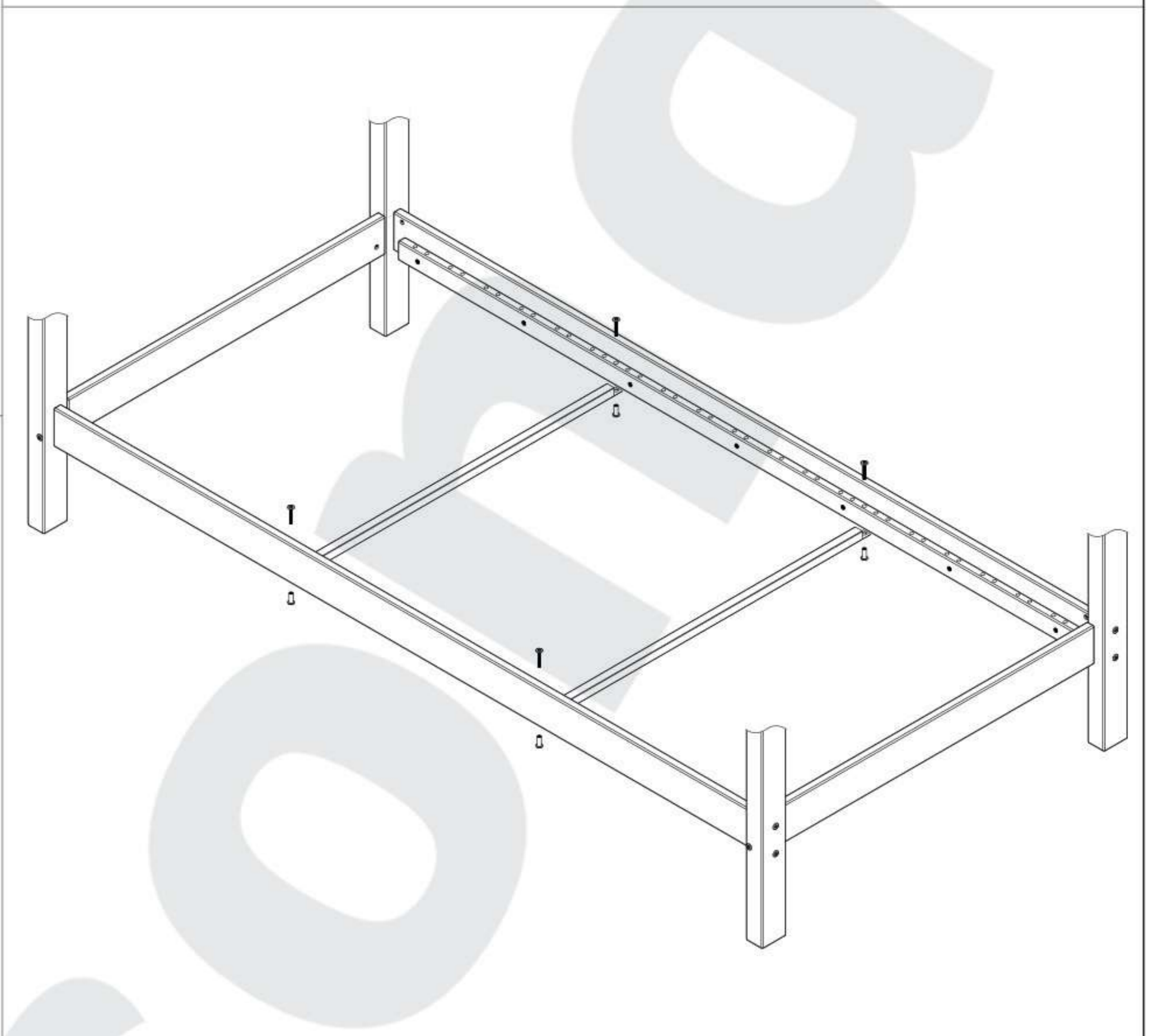
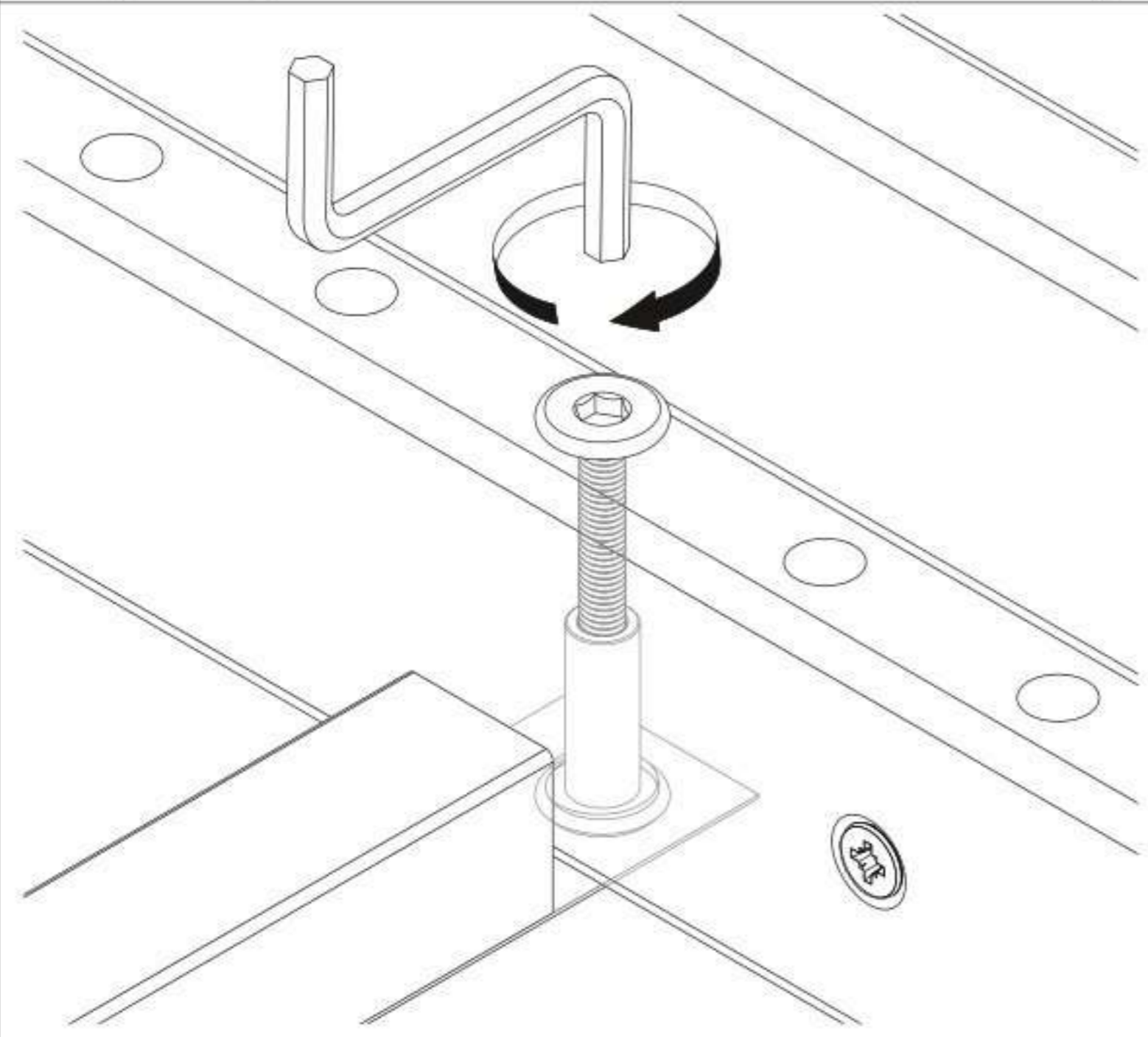
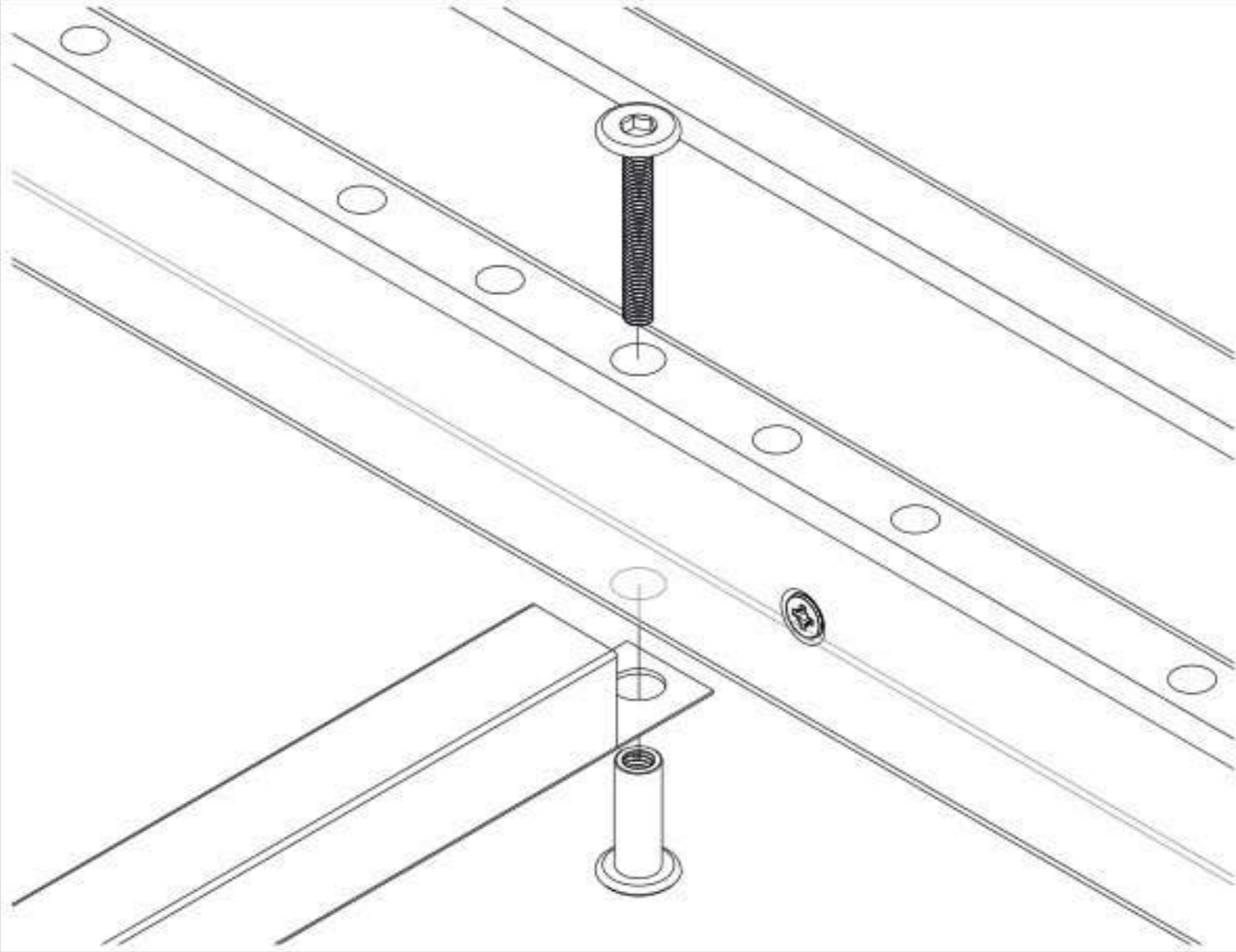

055	095

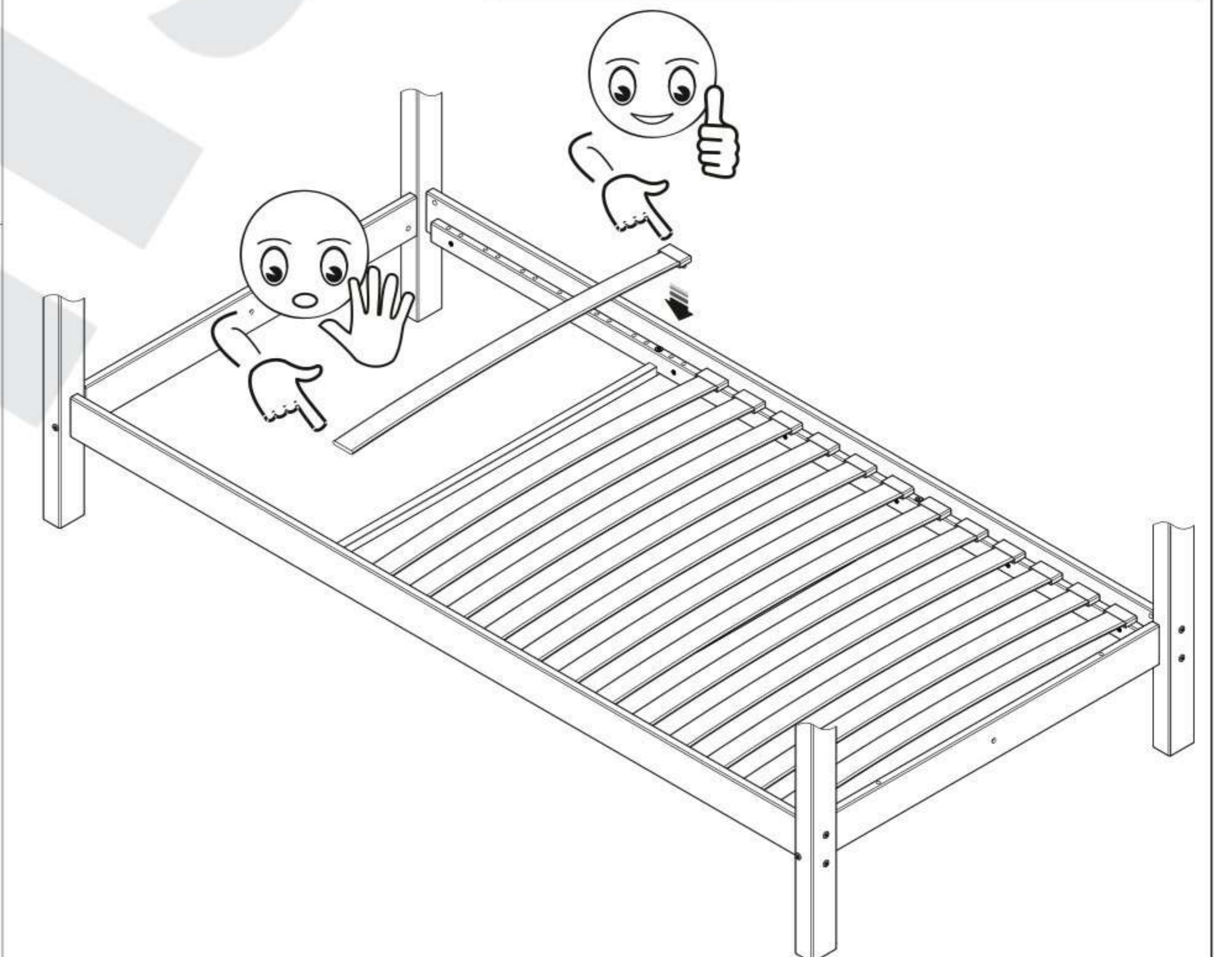
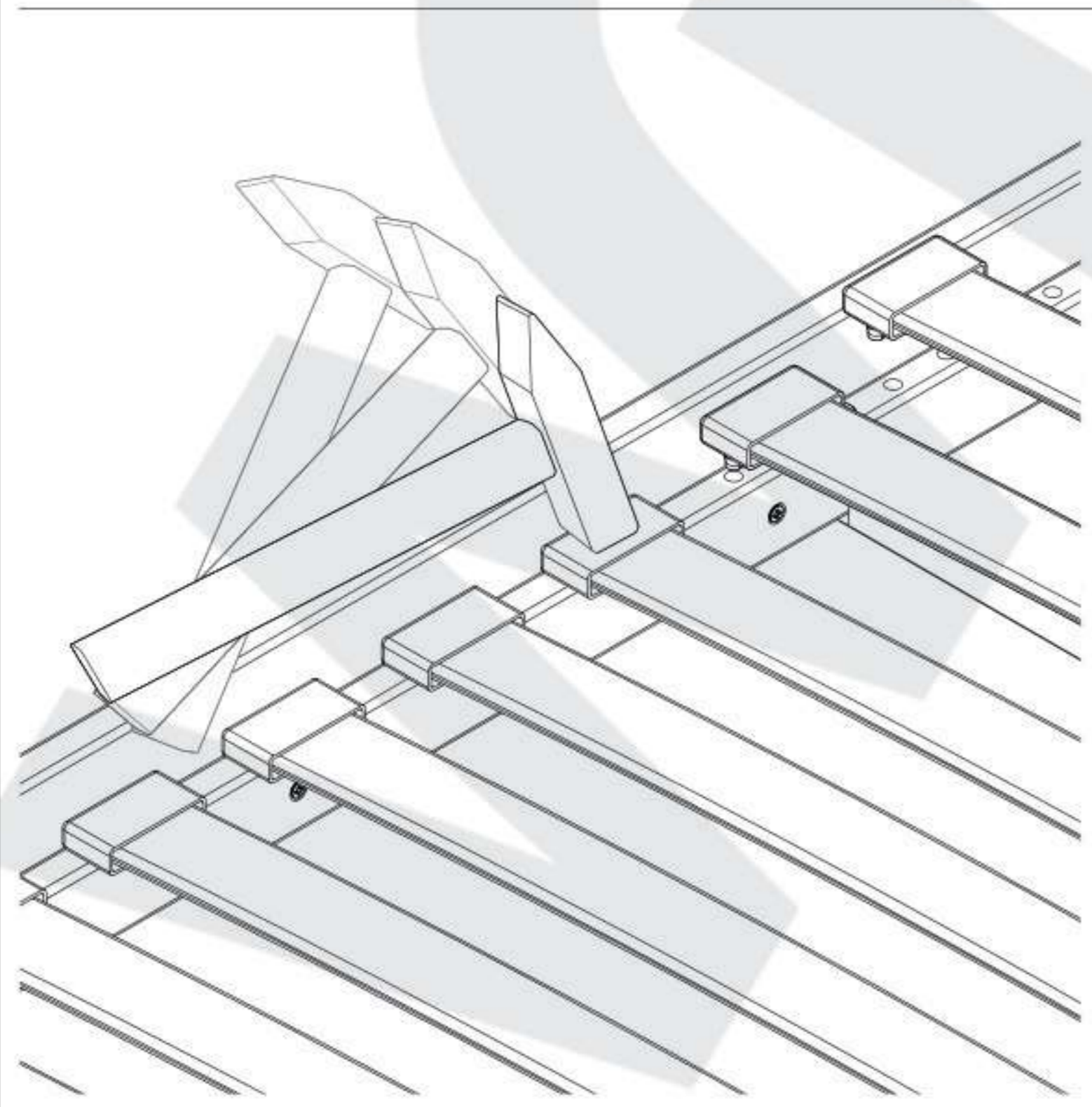

12

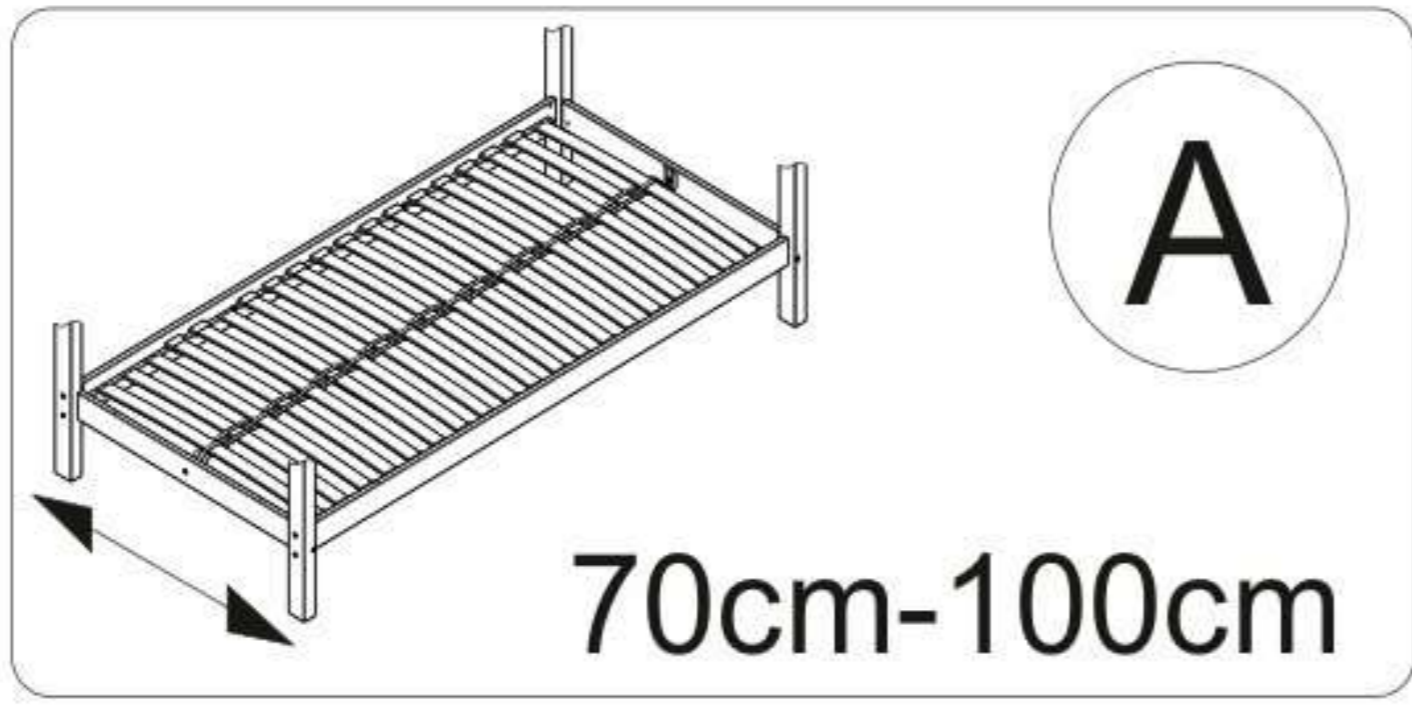

092

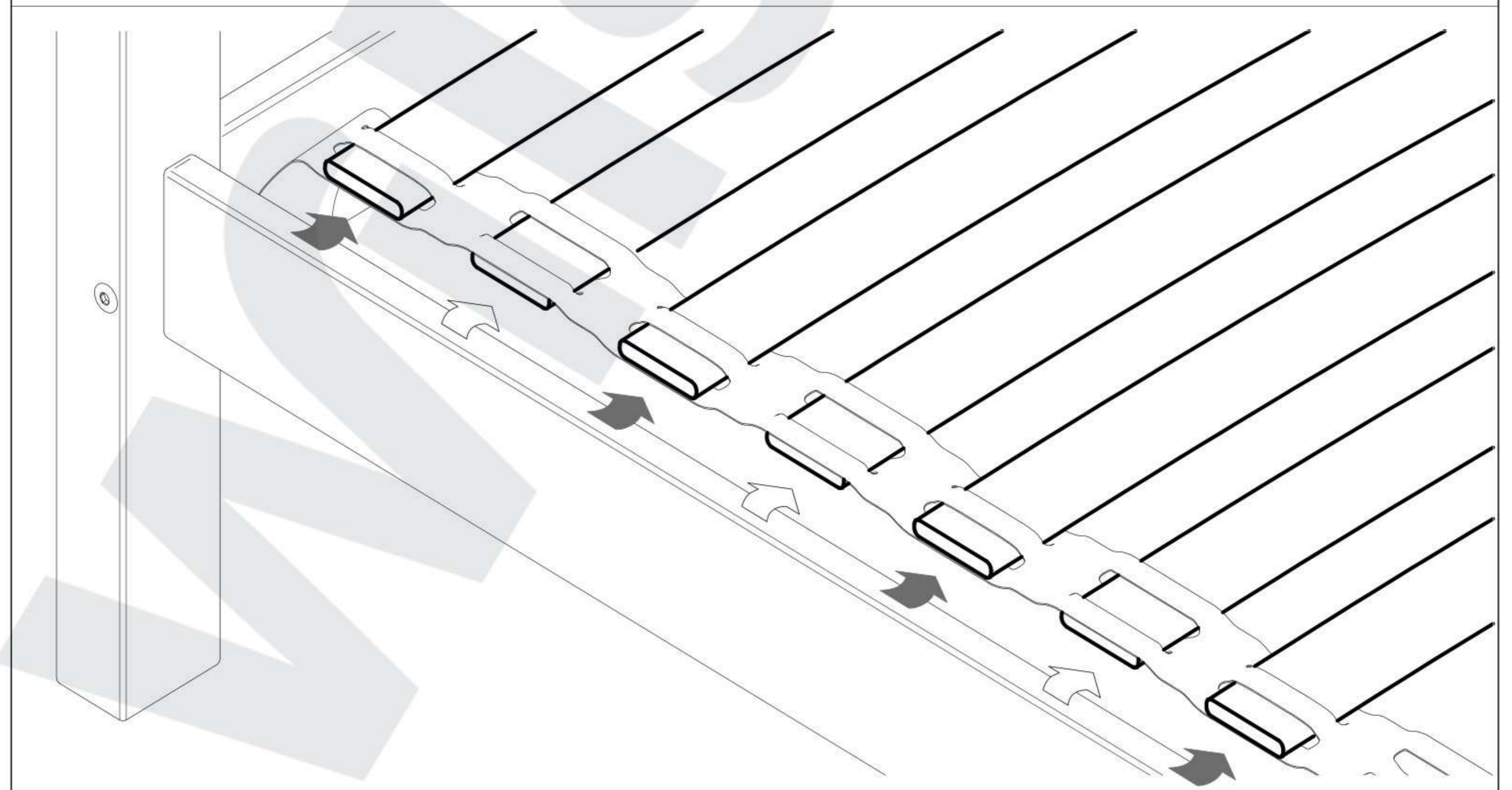
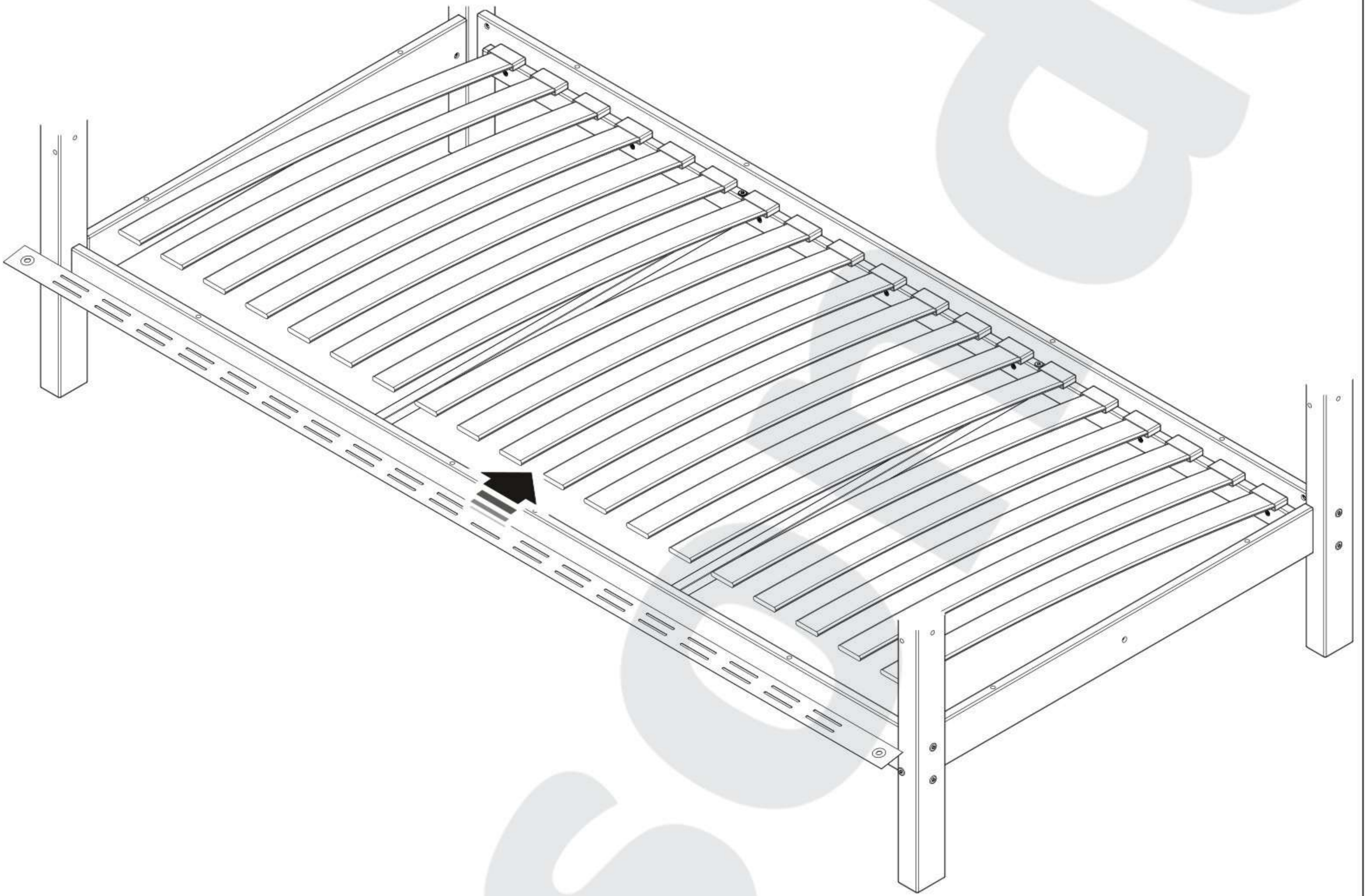
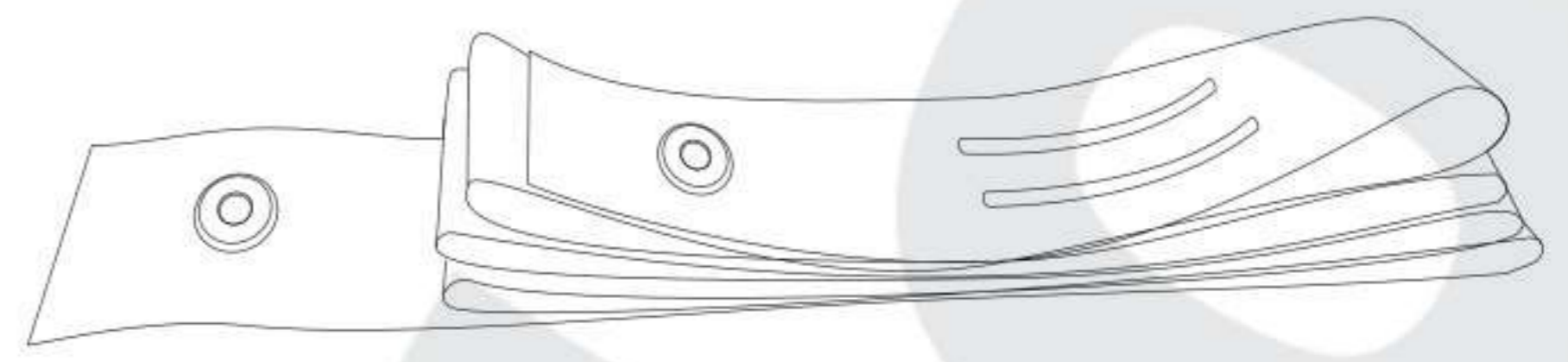

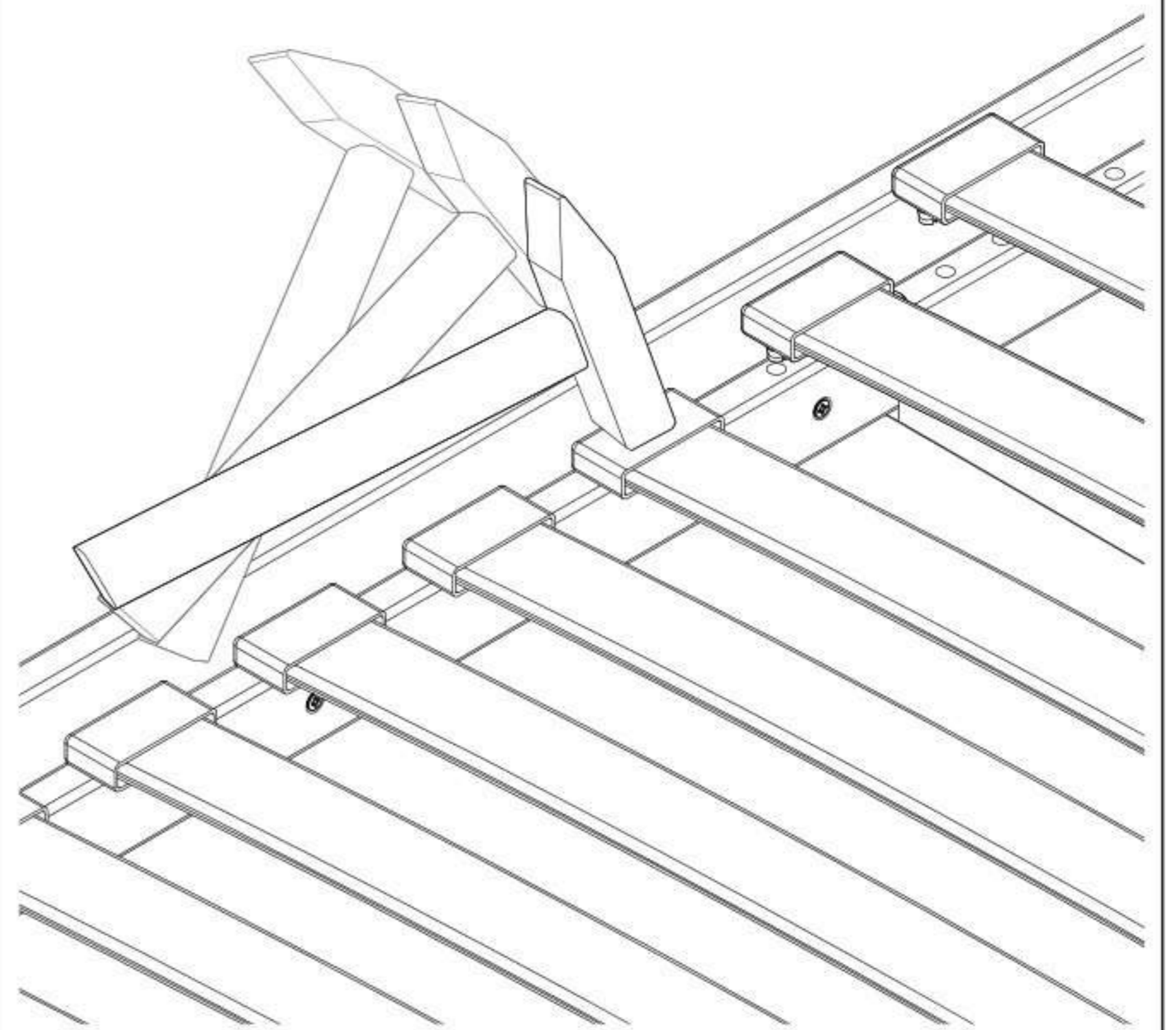
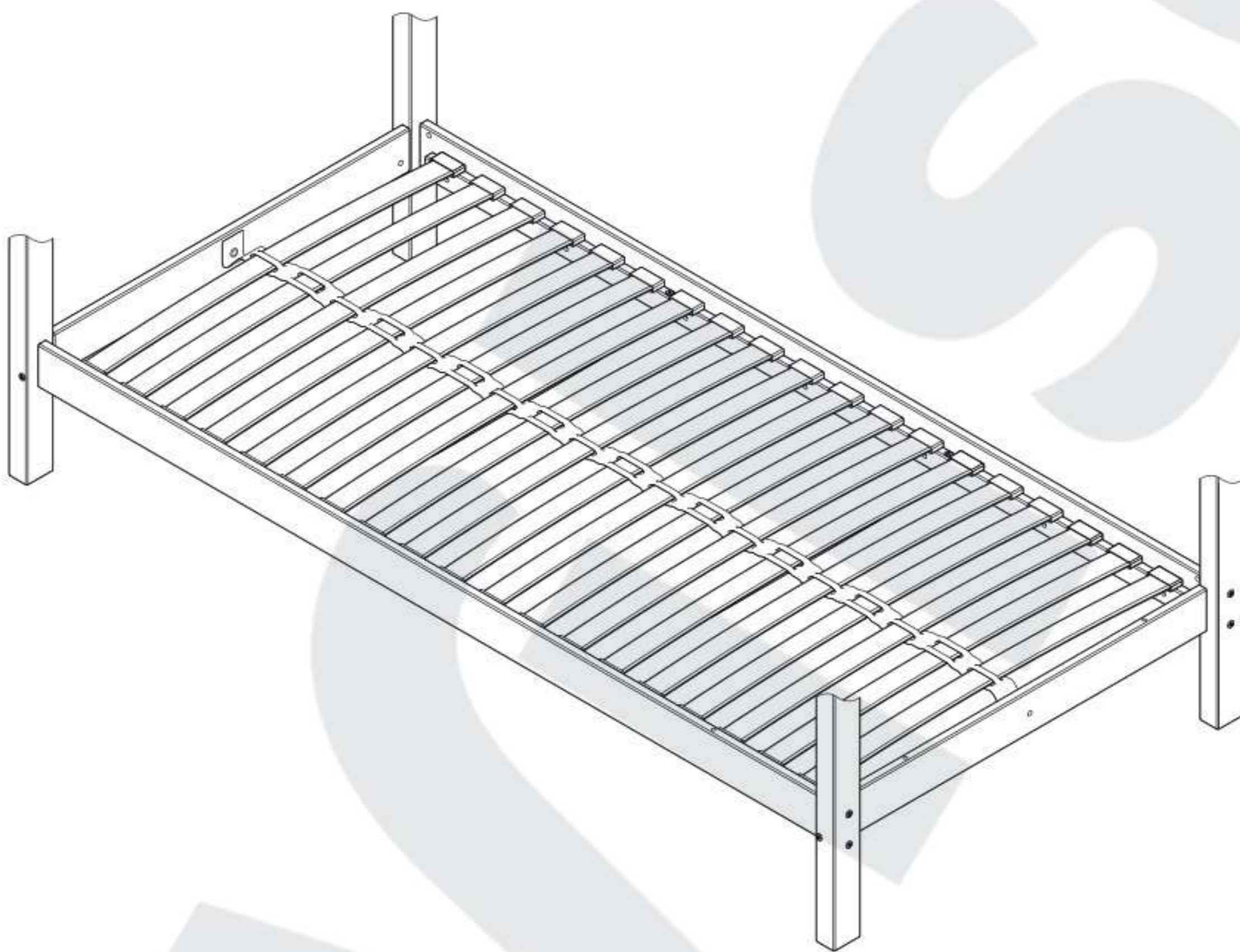
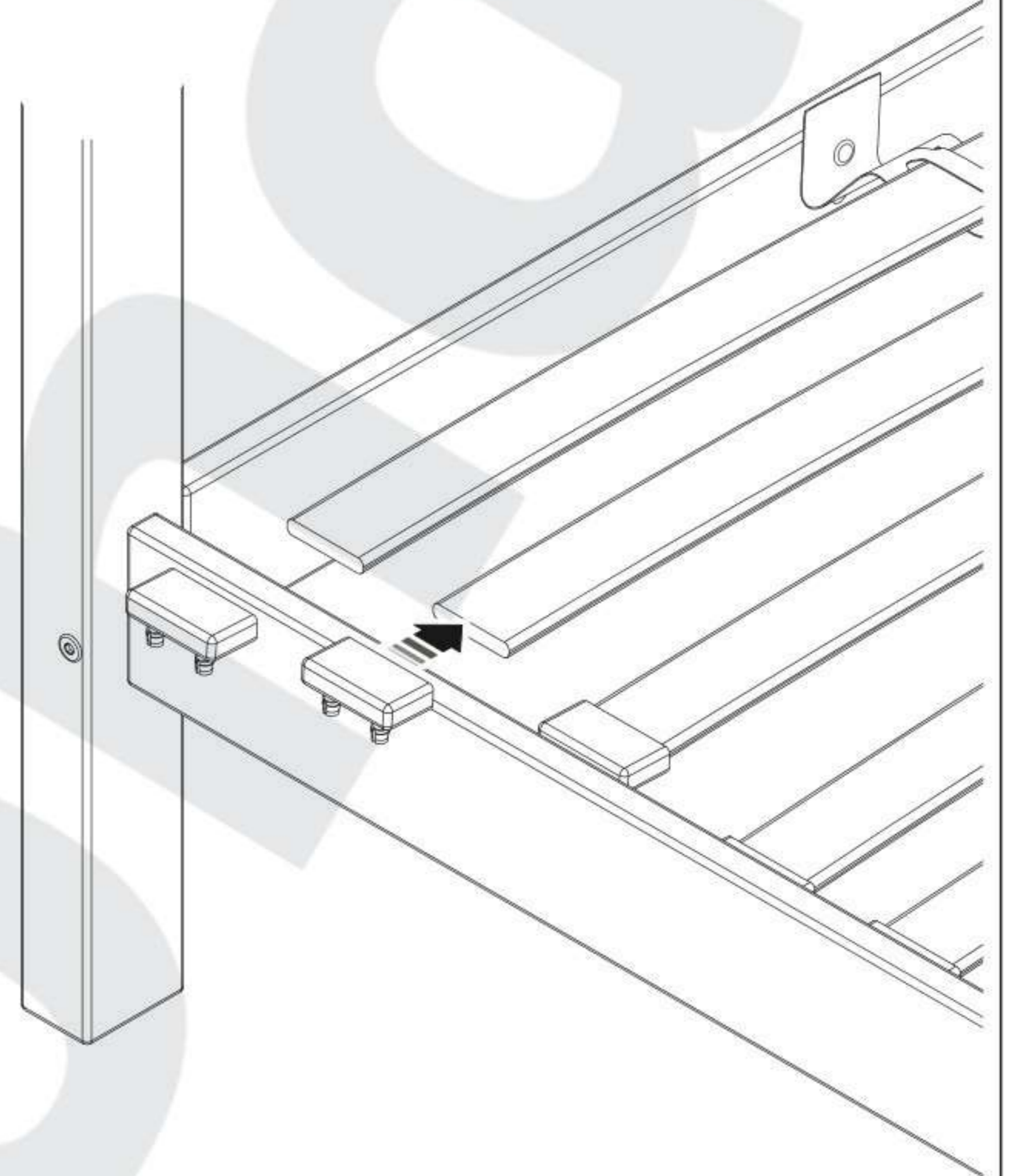
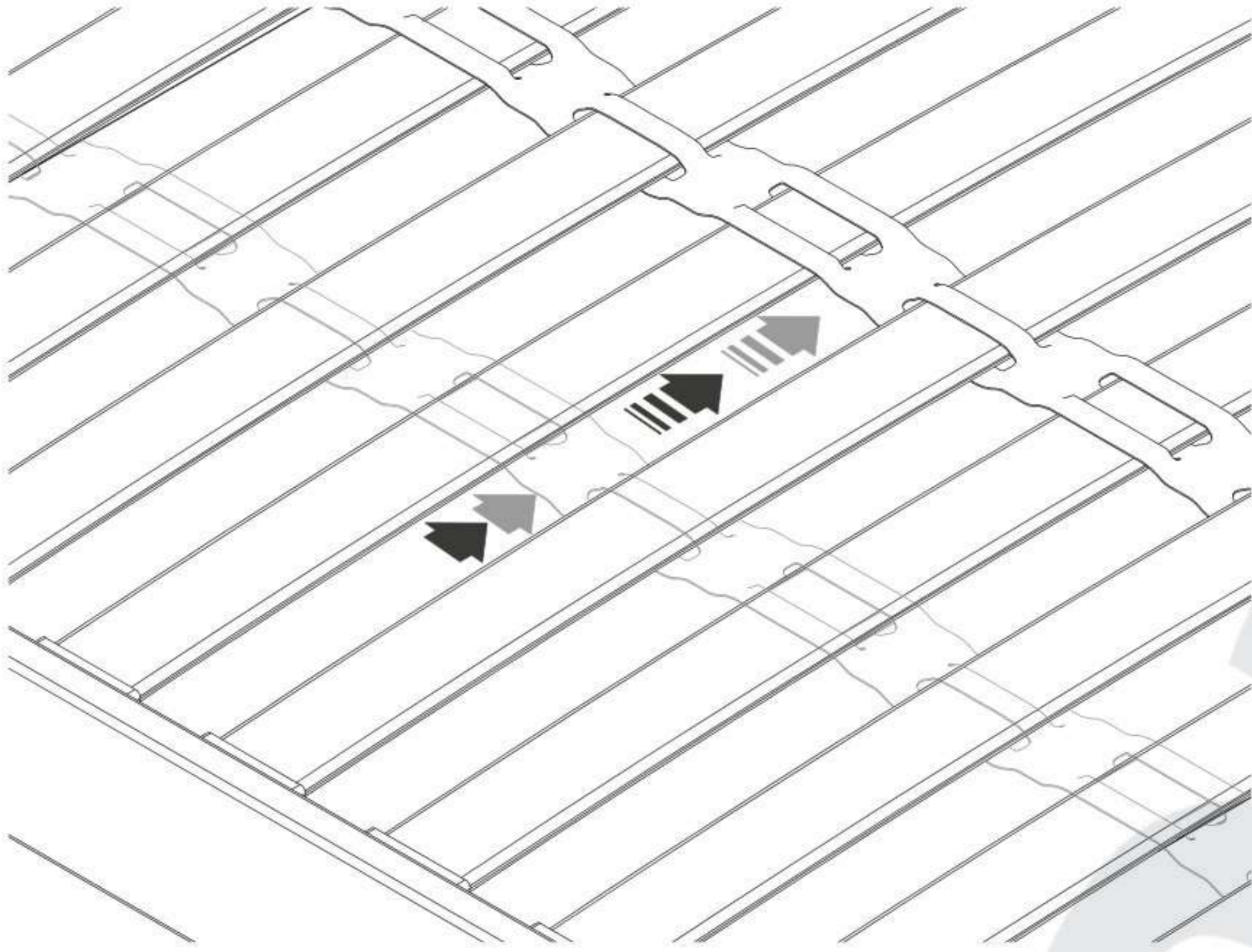
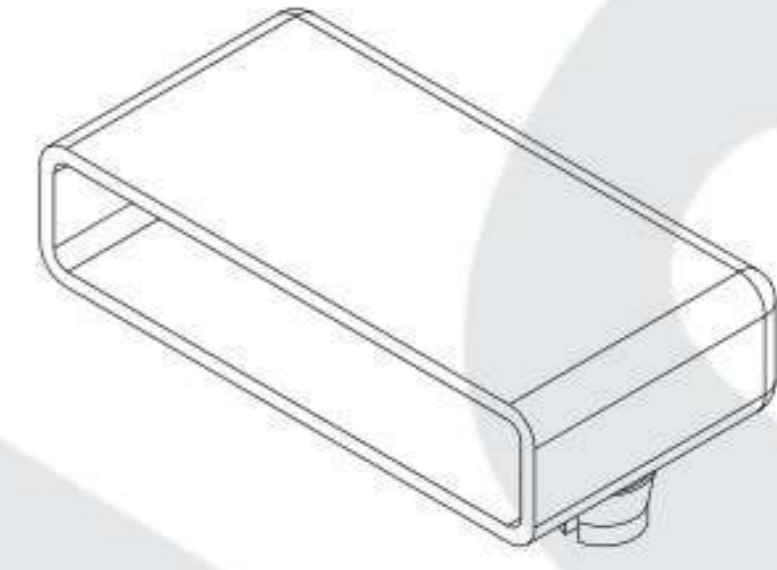
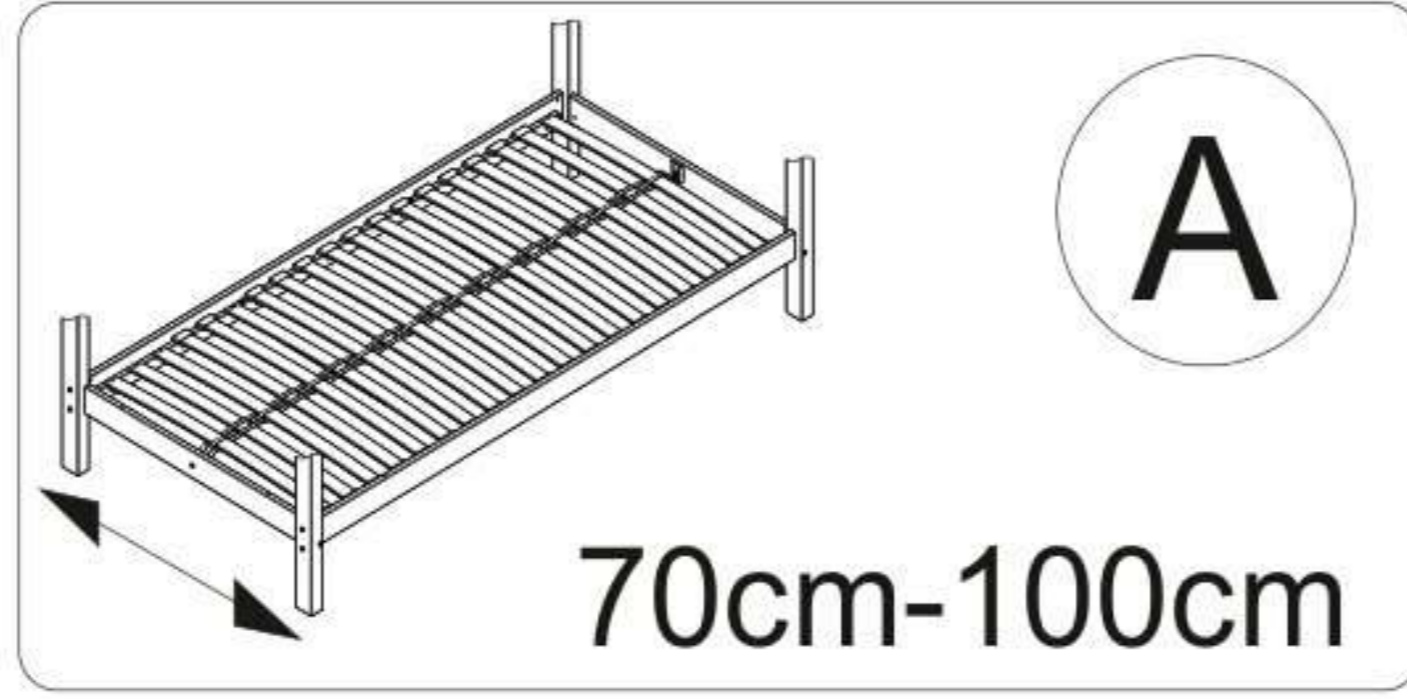

055

13

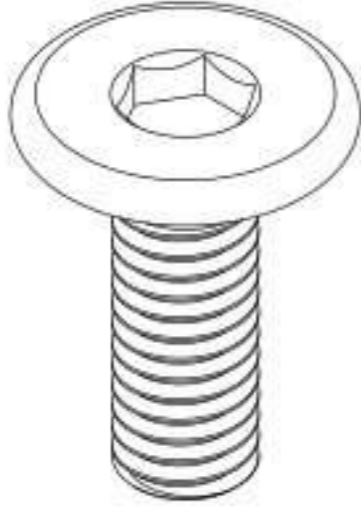
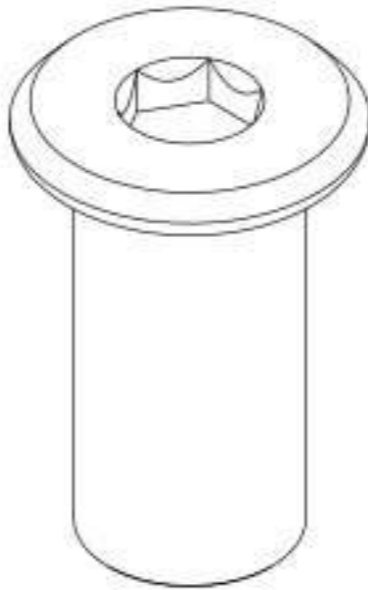

14

017	018	002
		
2x	2x	

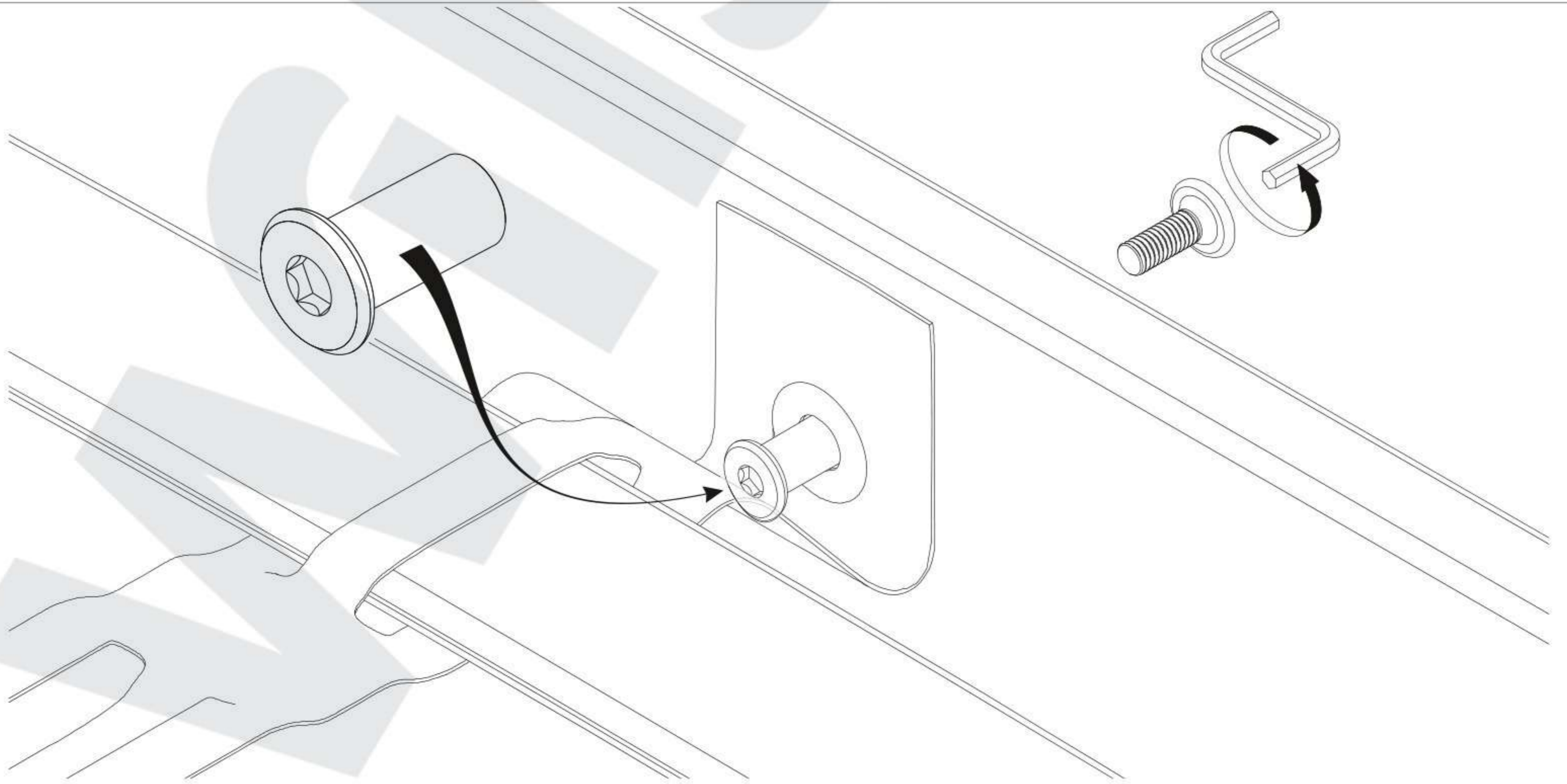
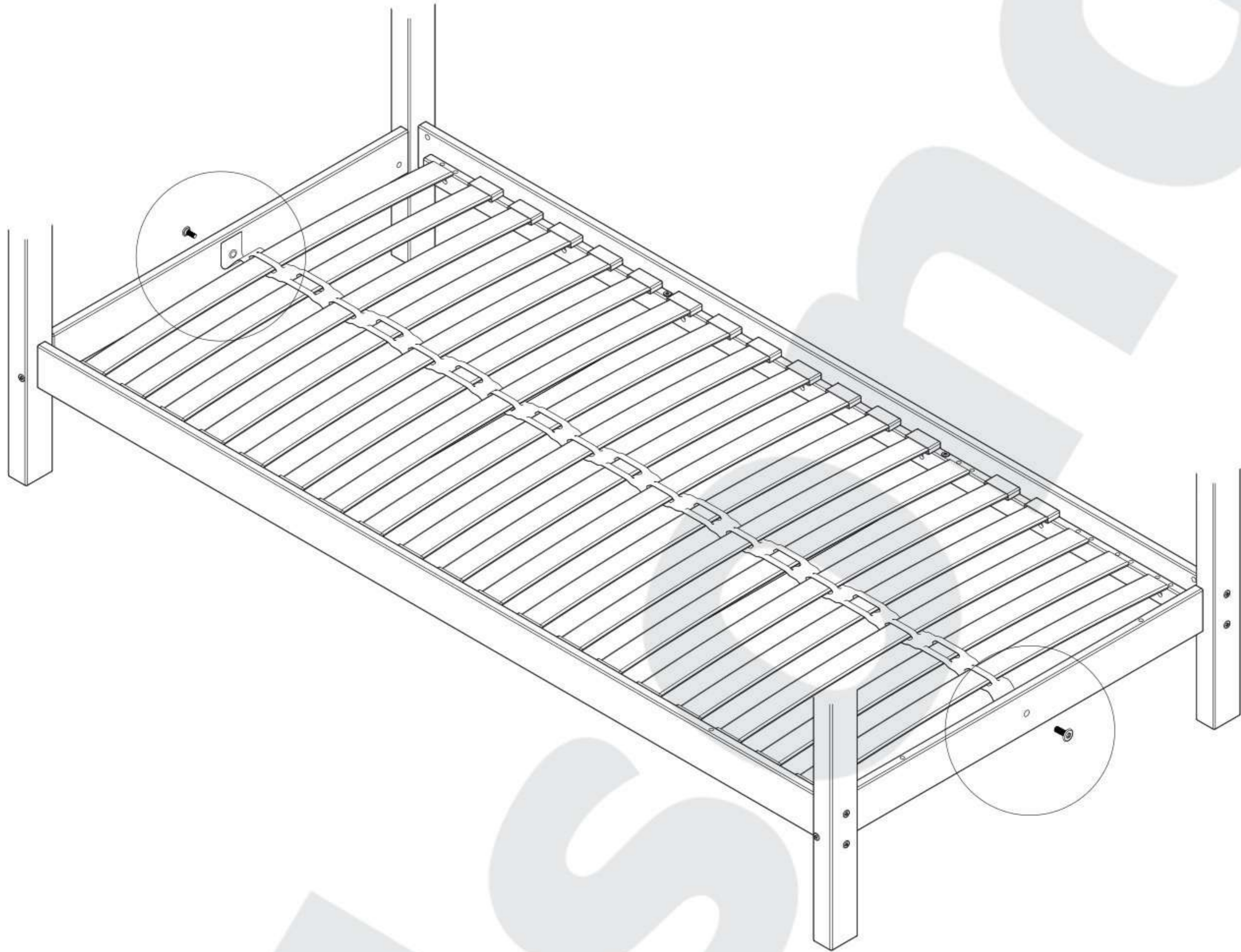
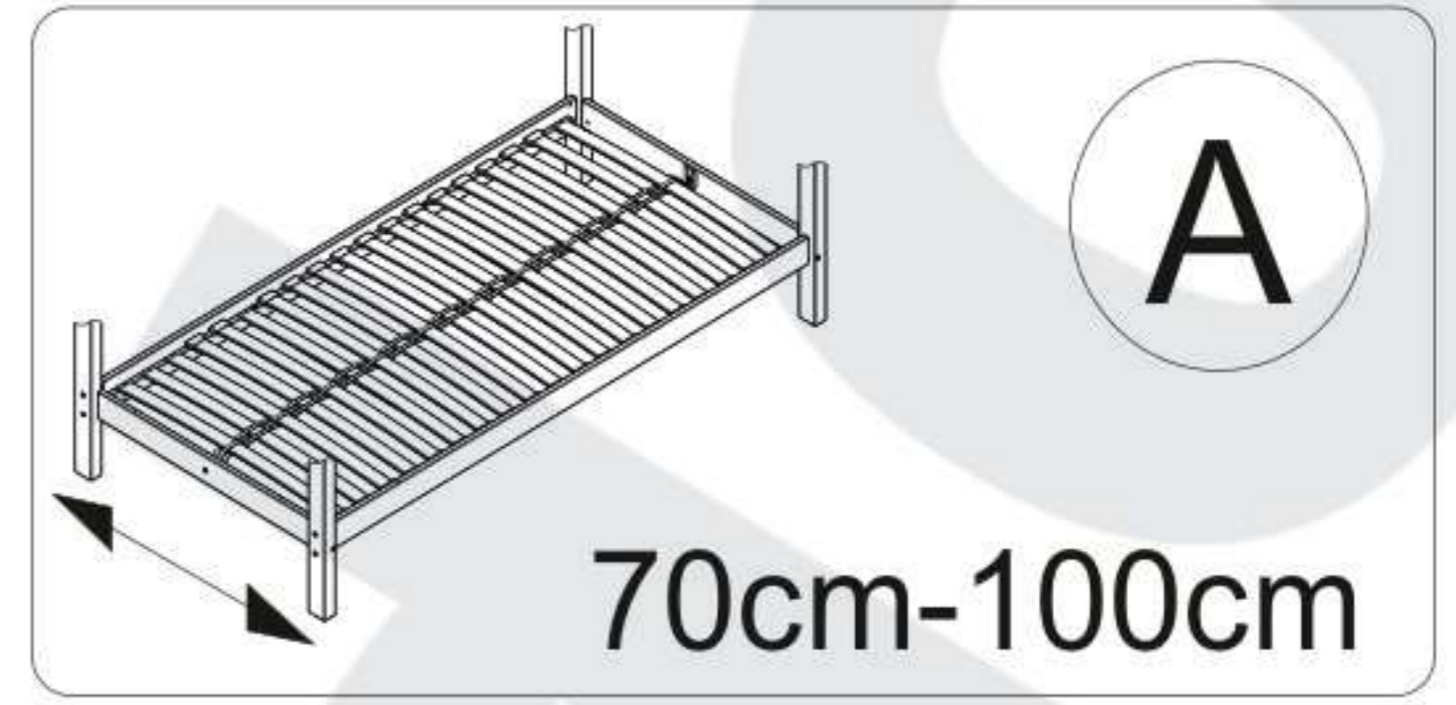

033

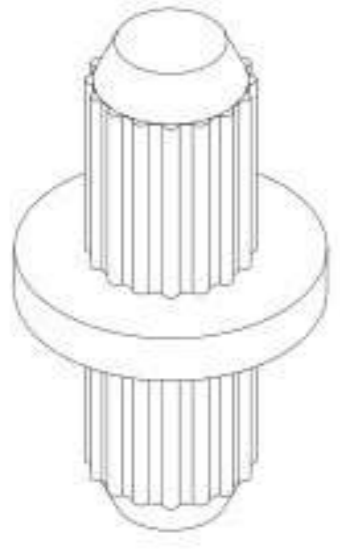

098

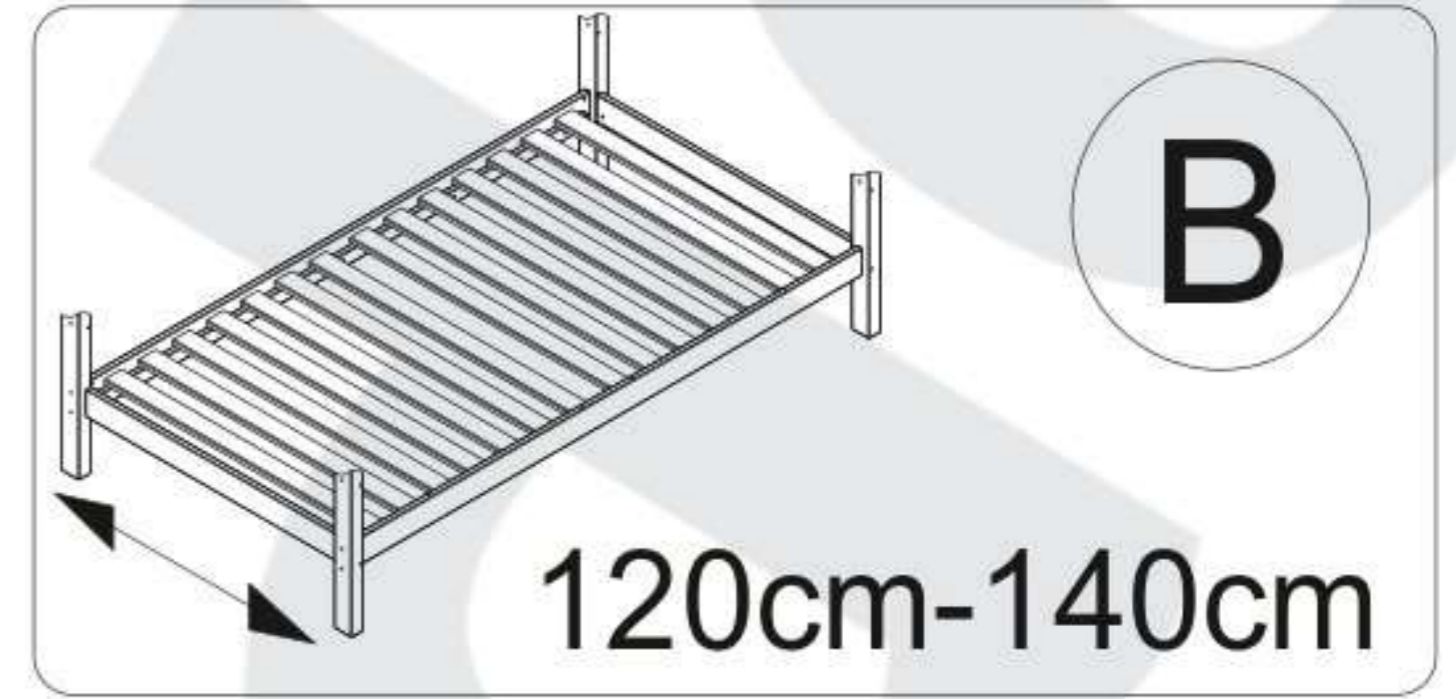
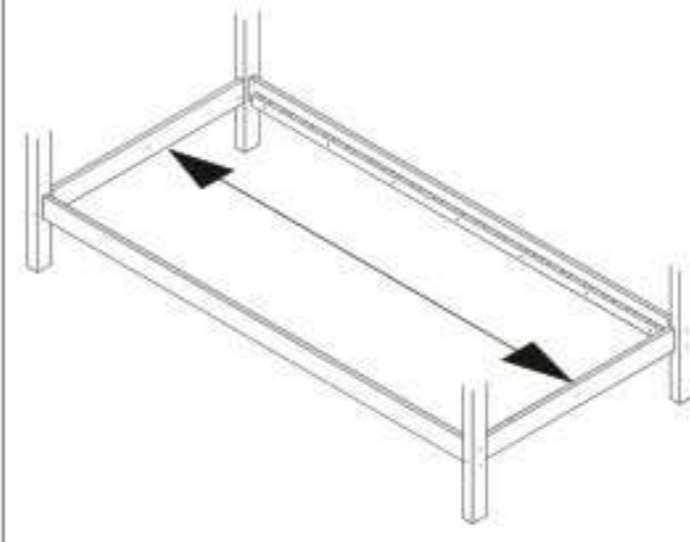
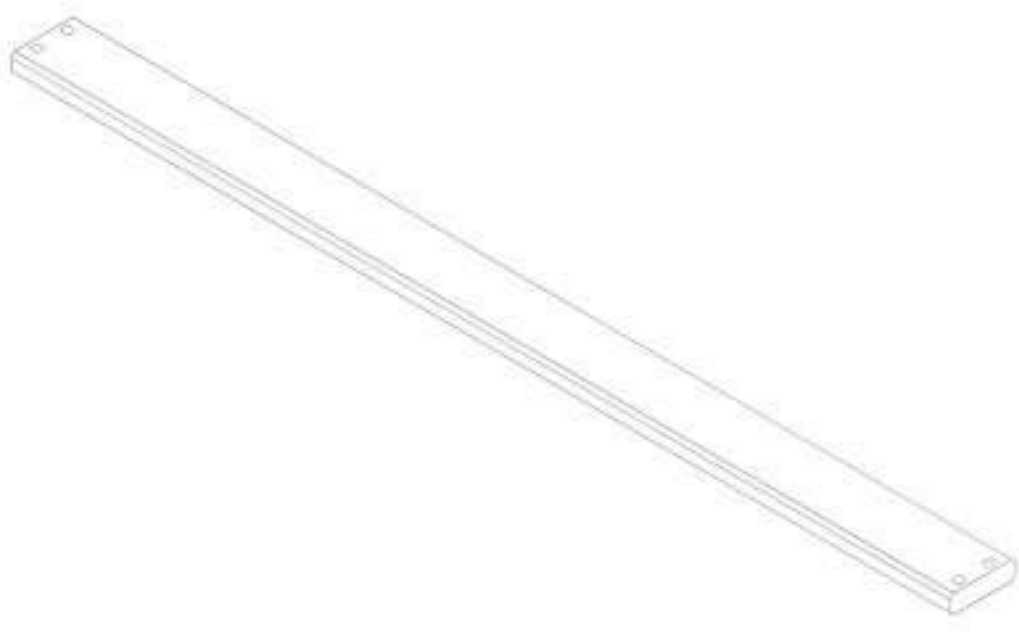

56x

14x

190cm

60x

15x

200cm

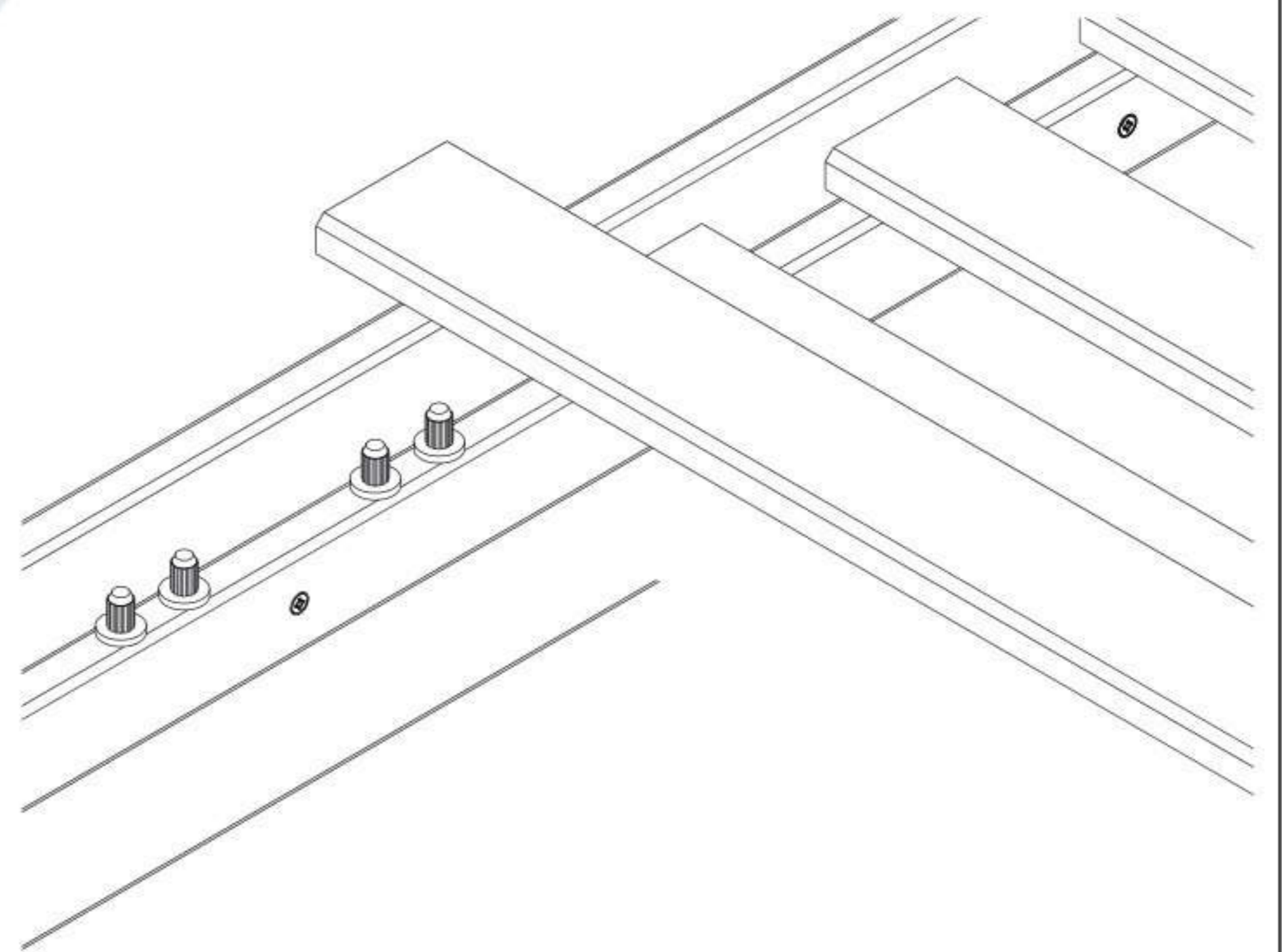
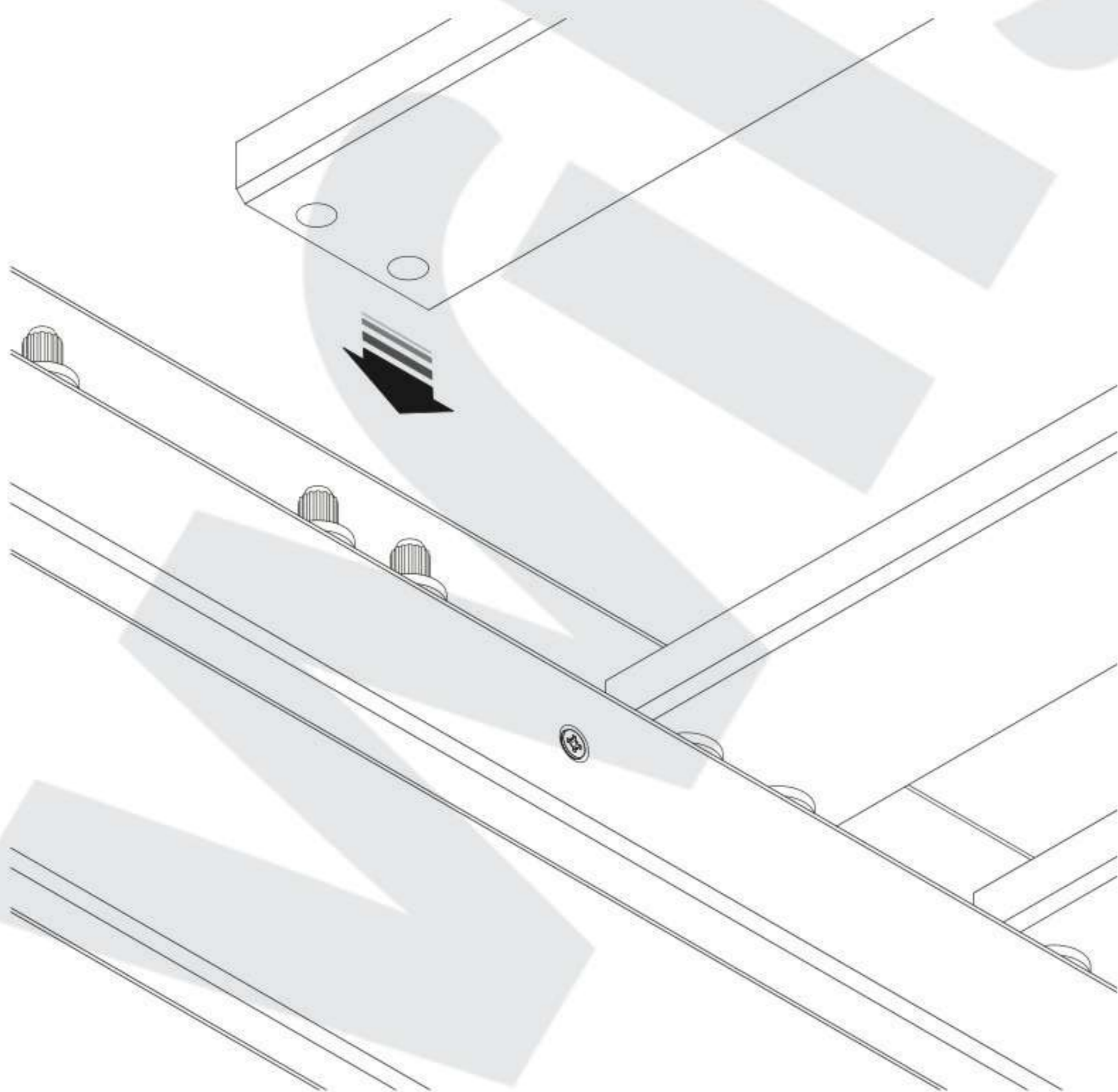
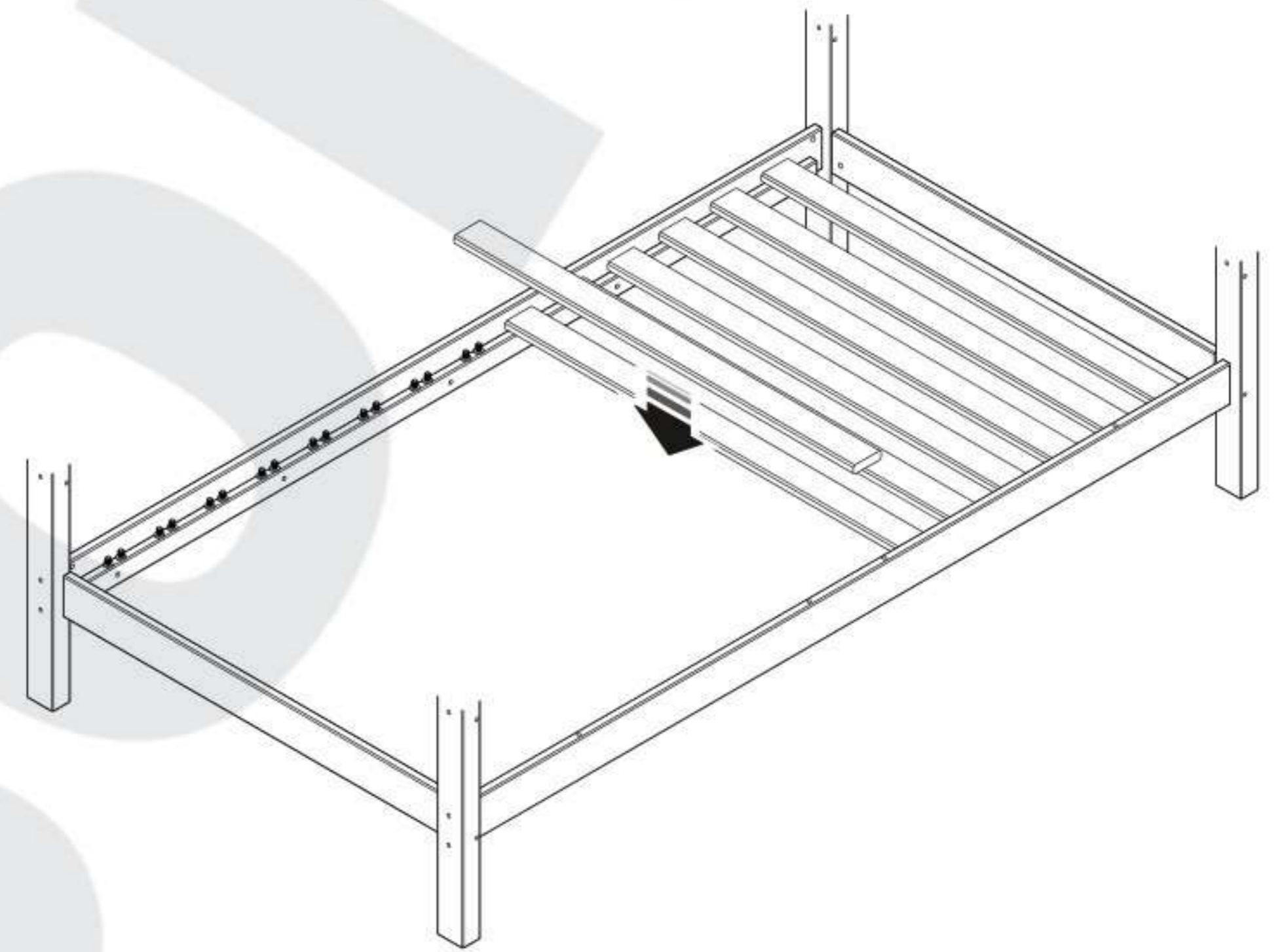
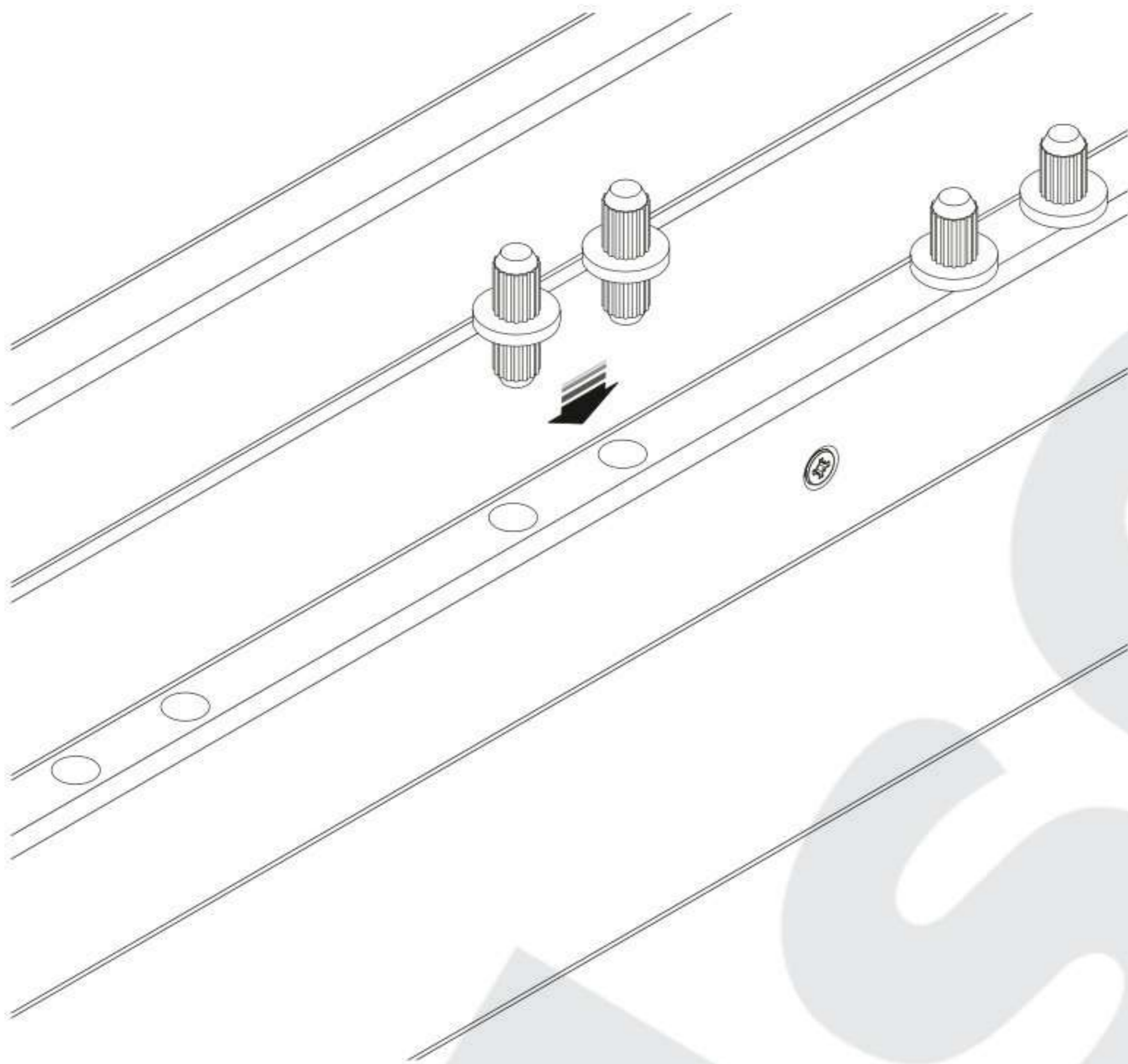

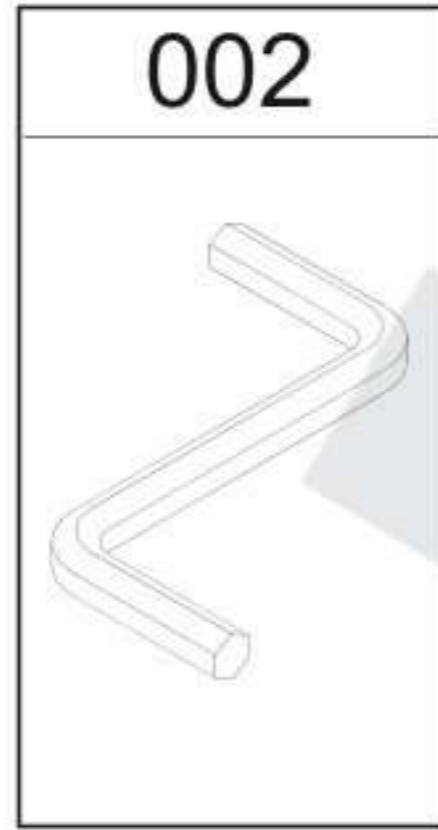
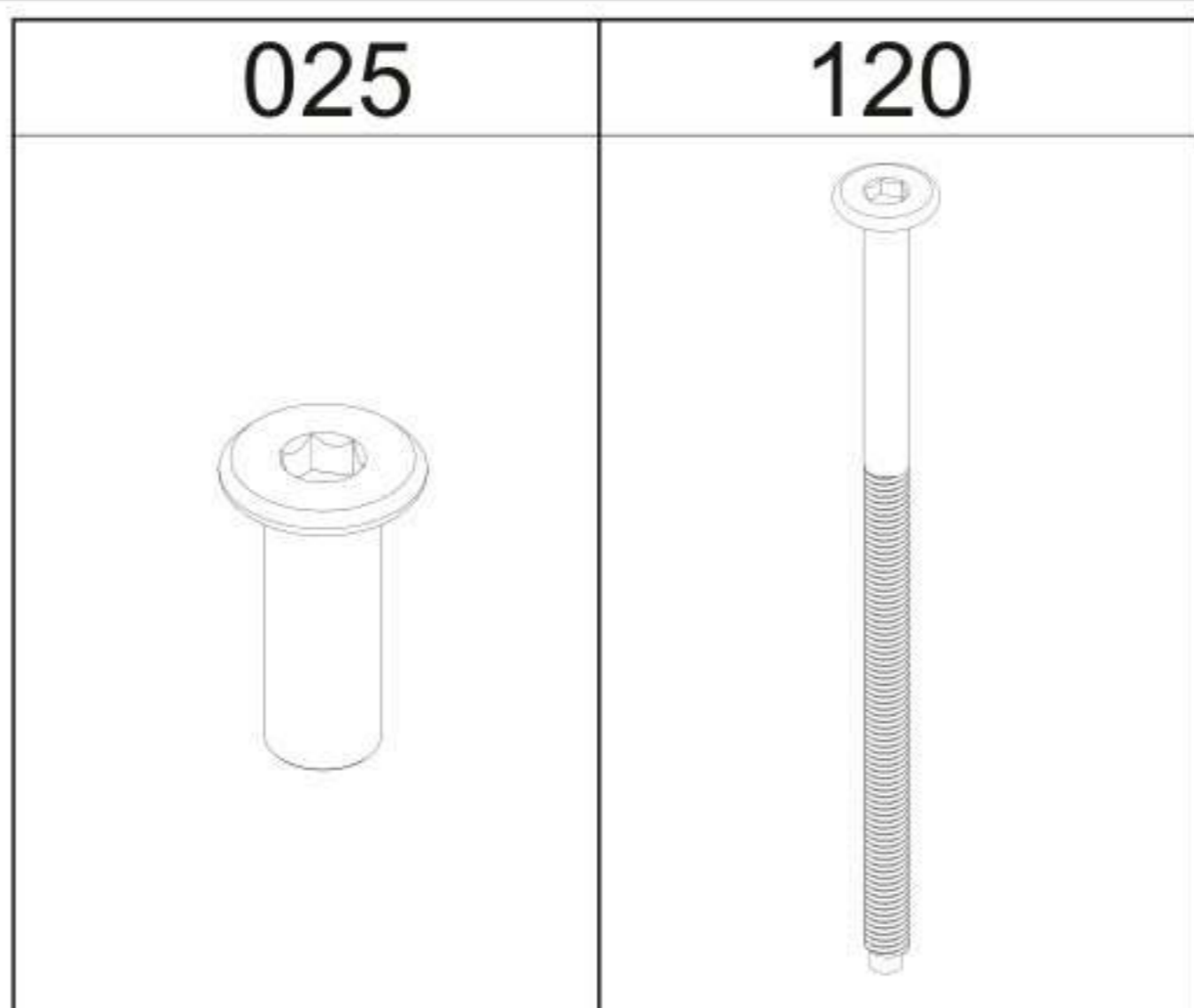

16

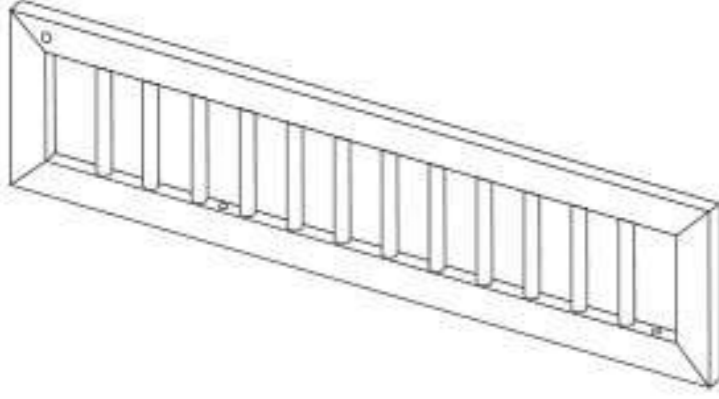

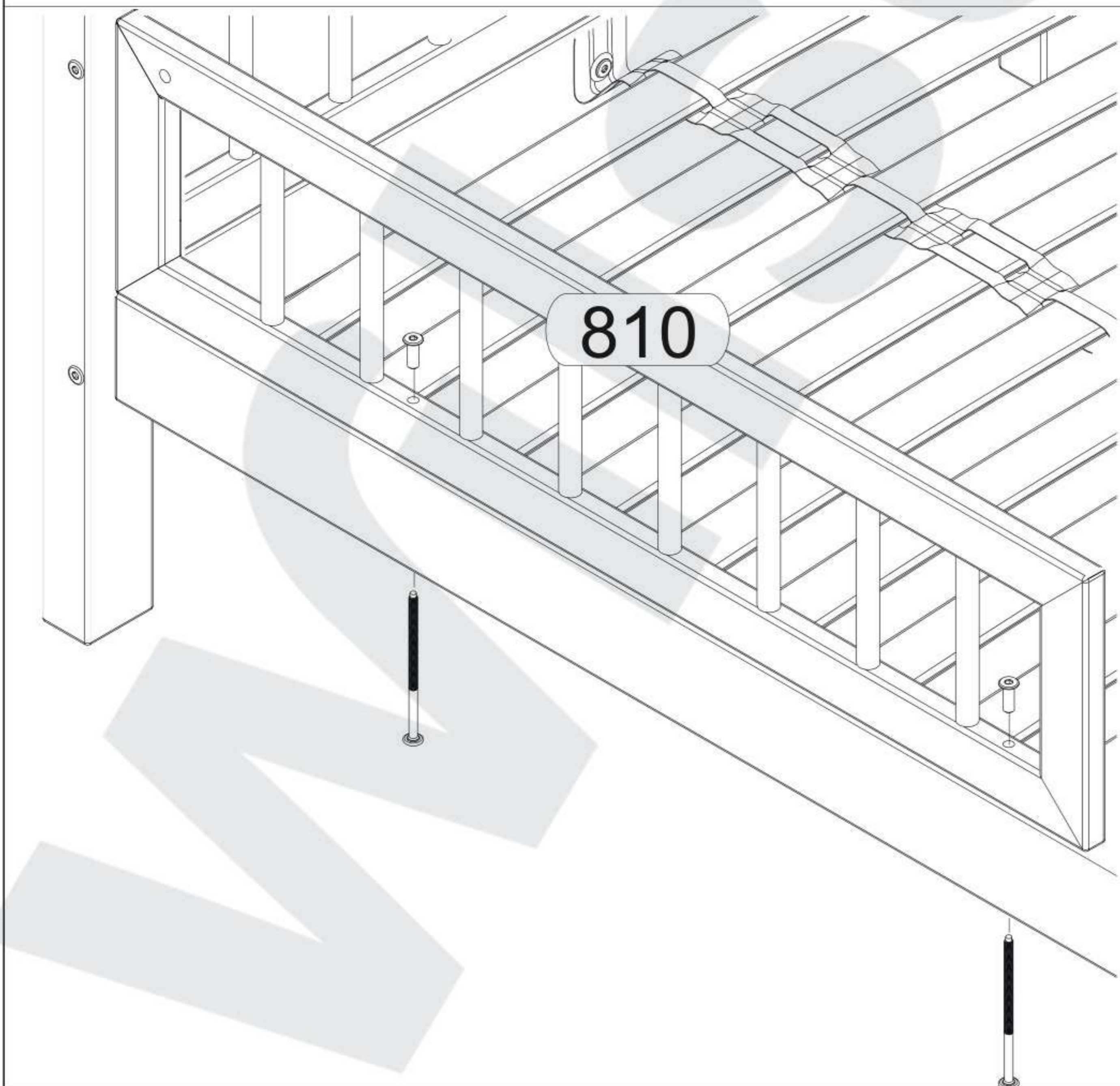
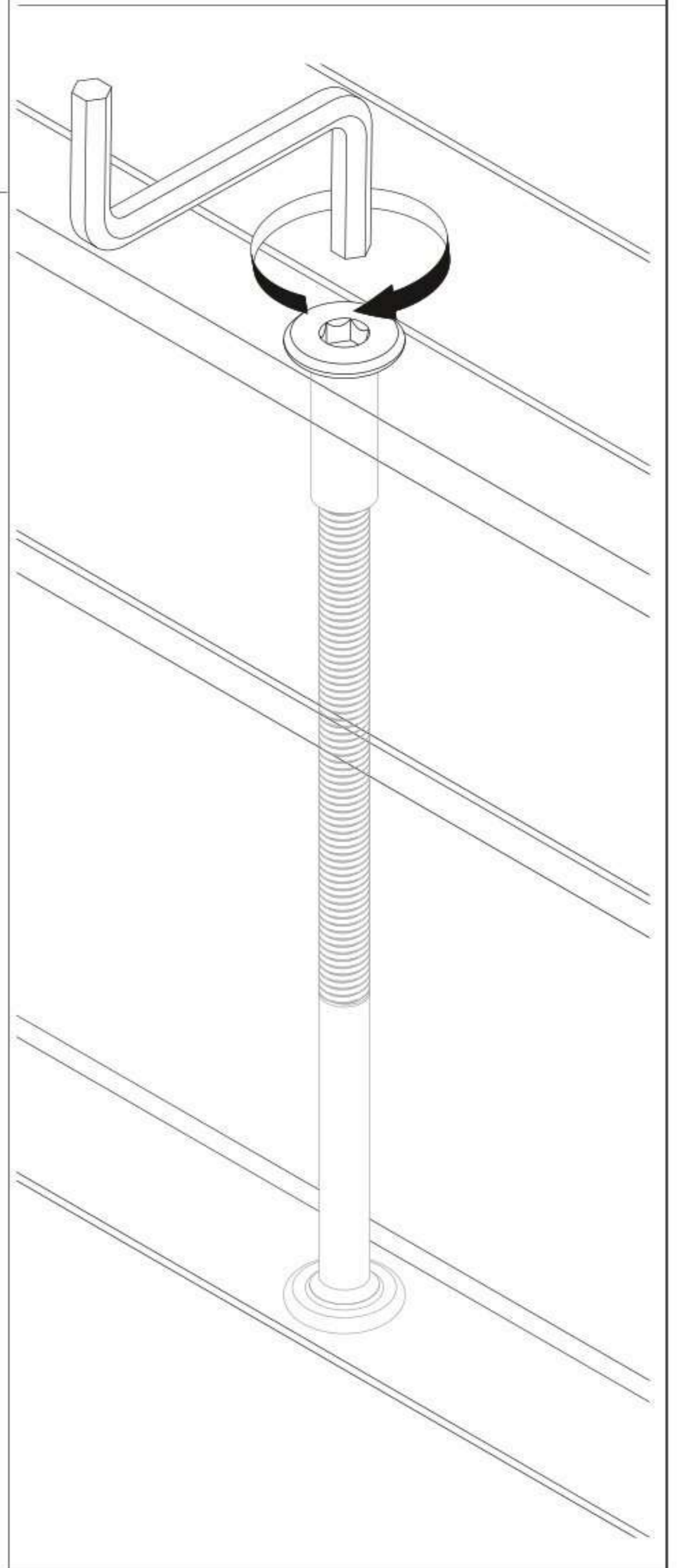
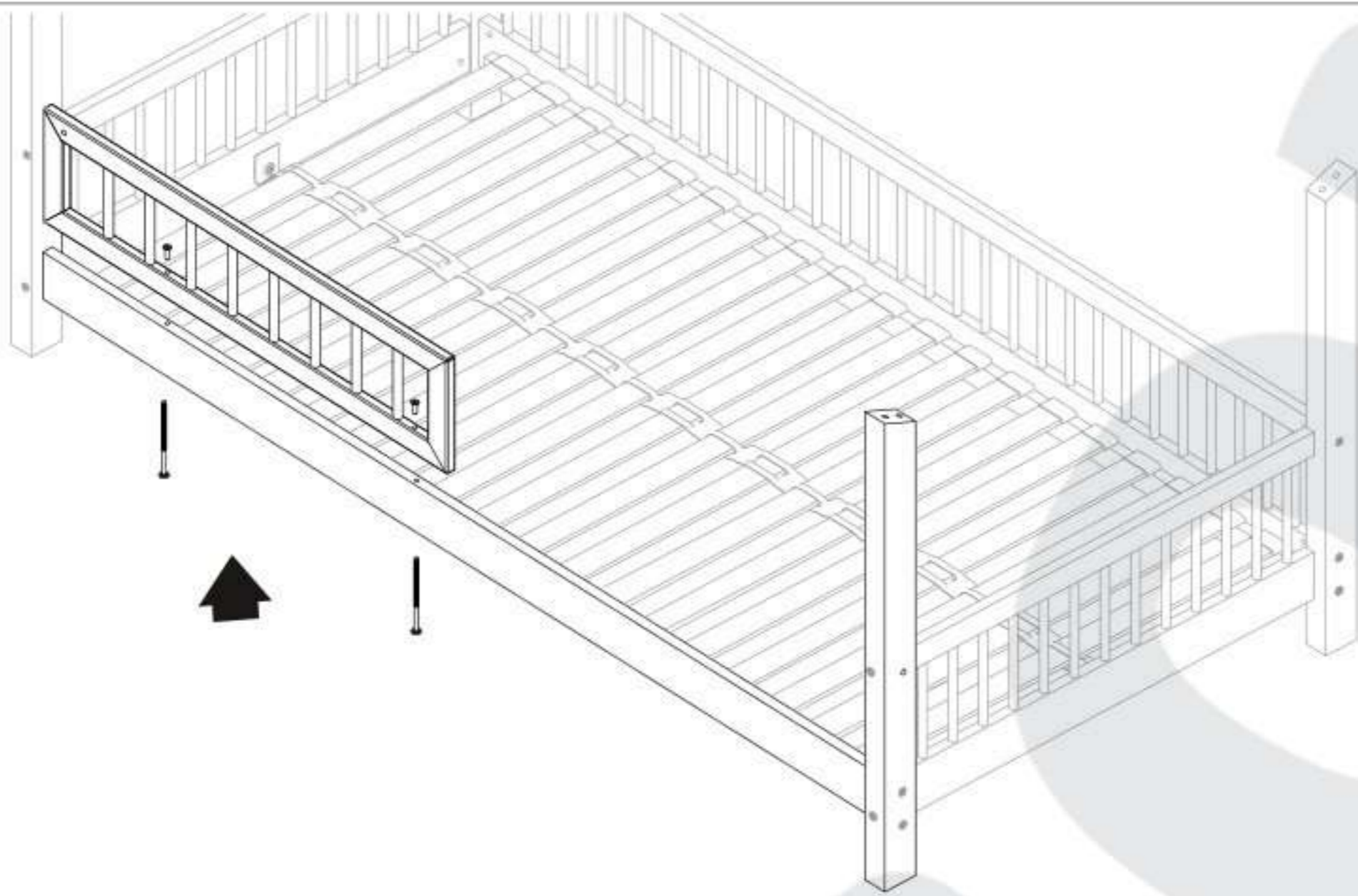
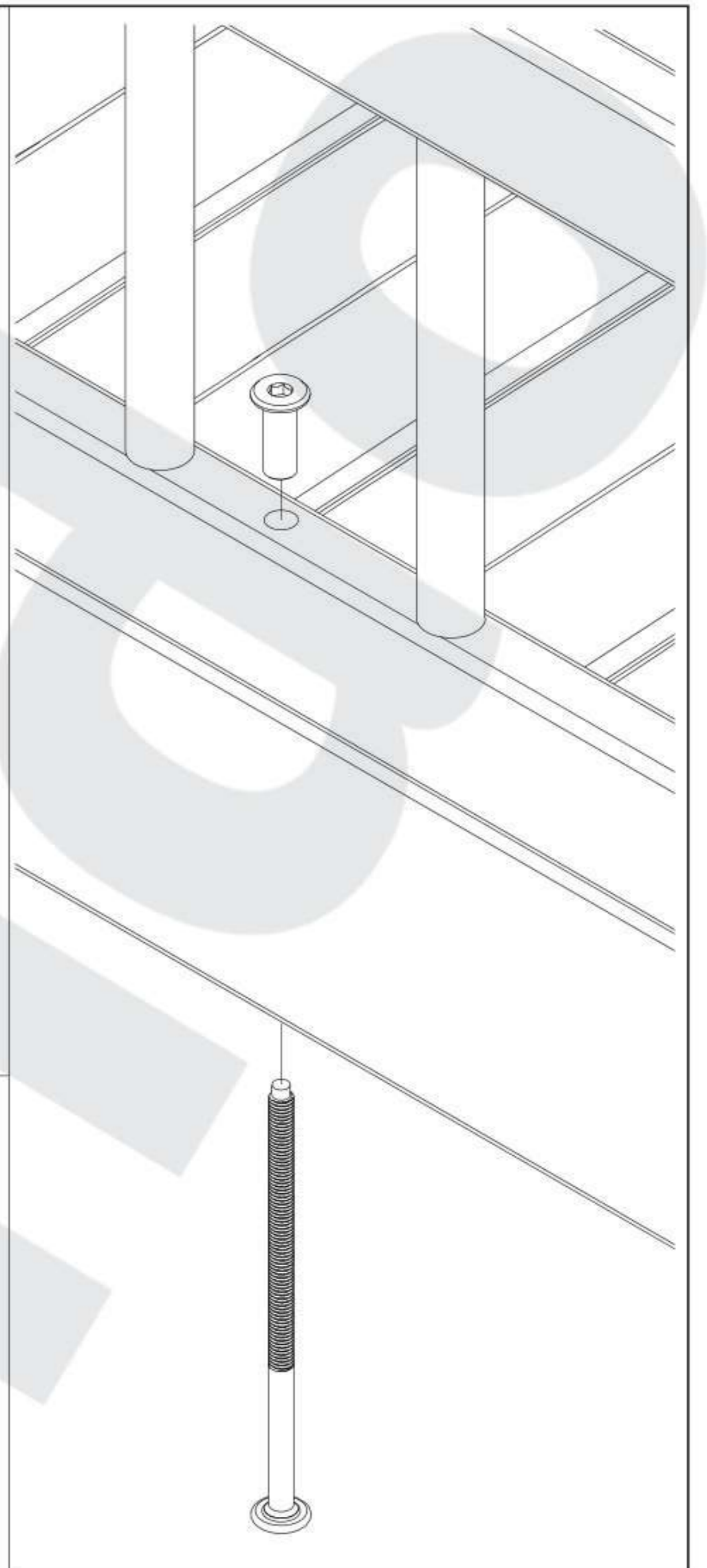
	140cm	160cm	180cm	190cm	200cm
 1/2	2x	2x	2x	2x	2x
2/3	2x	2x	4x	4x	4x
3/4	2x	4x	4x	4x	4x



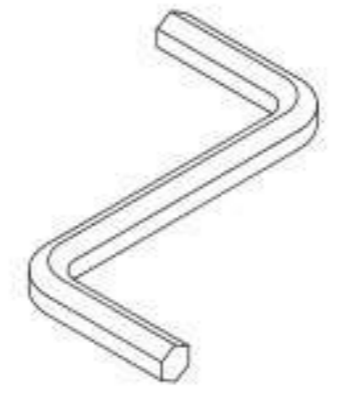

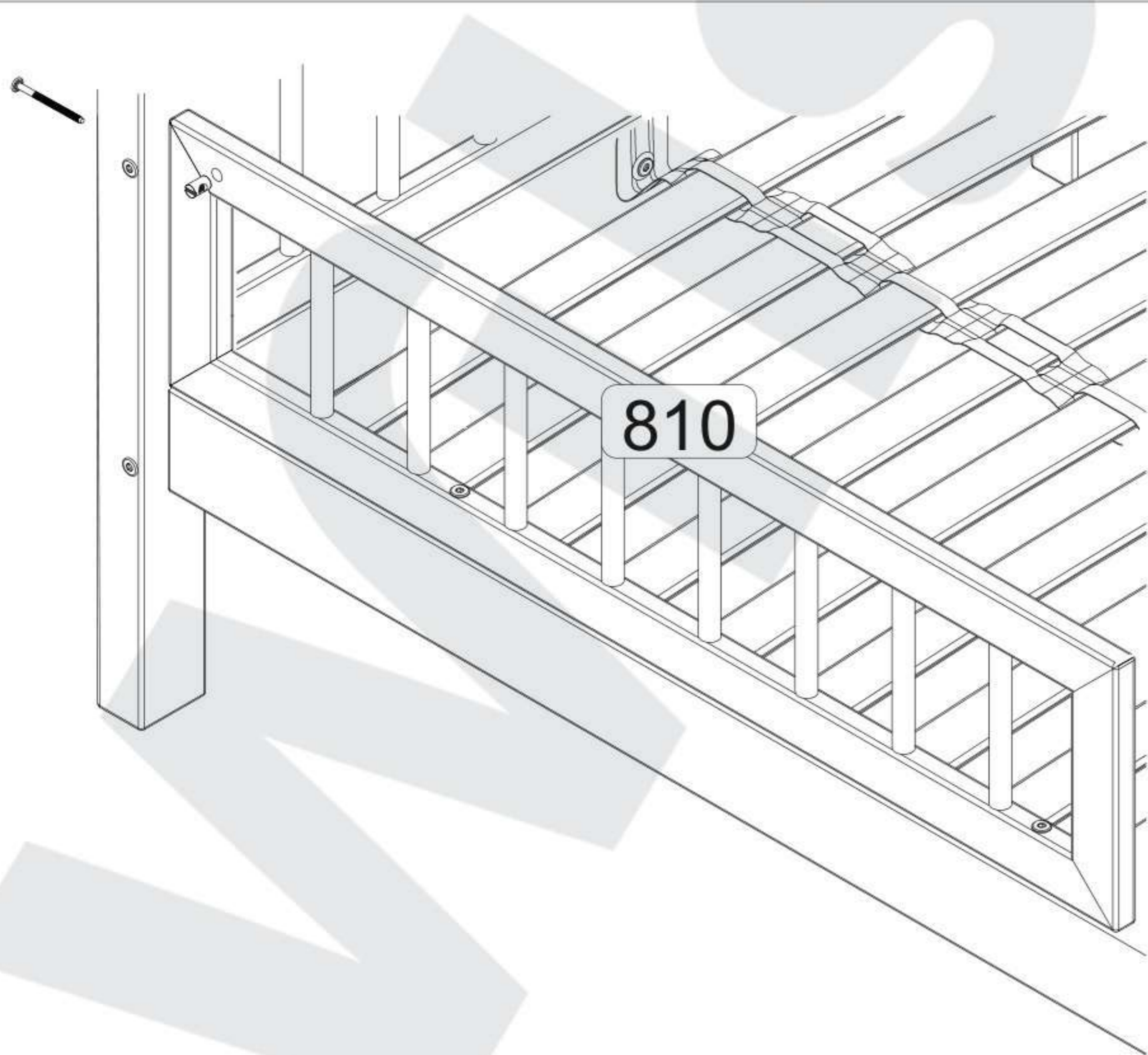
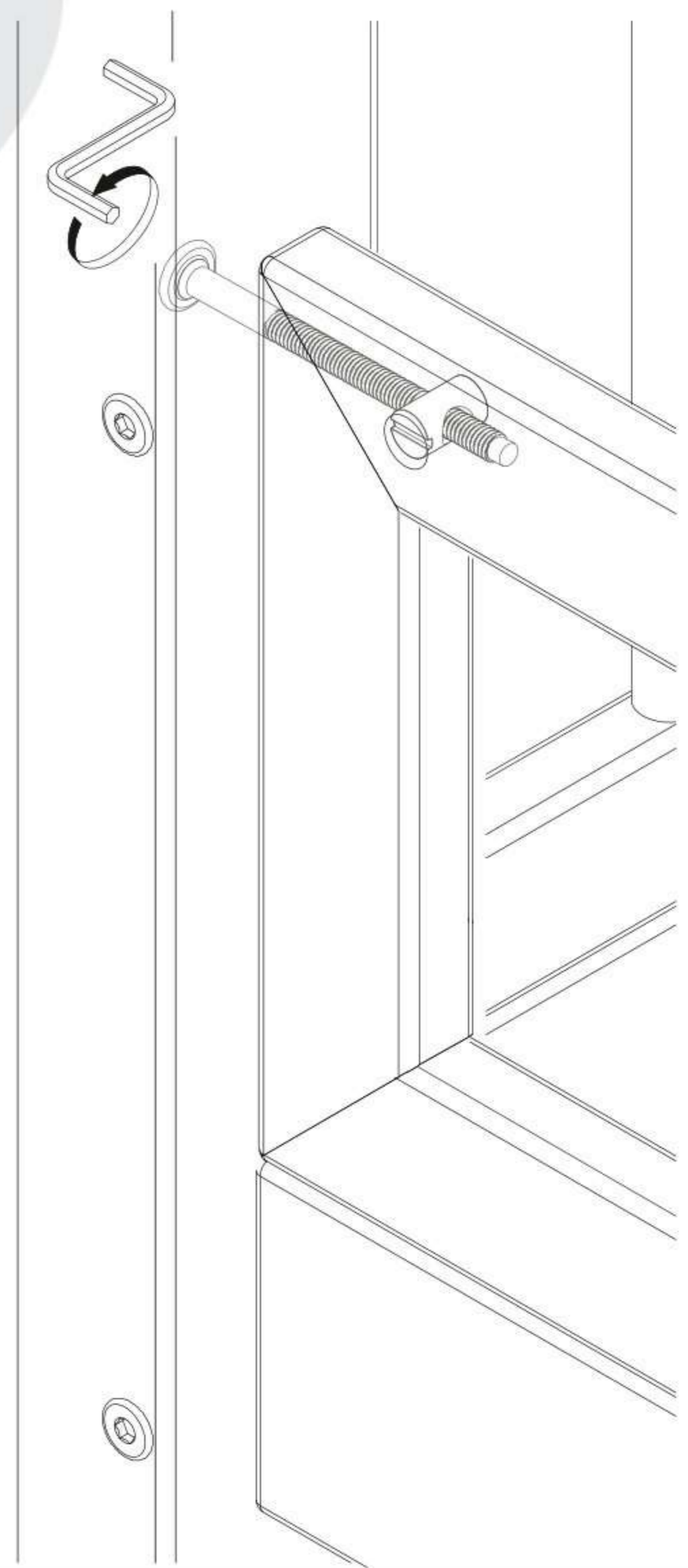
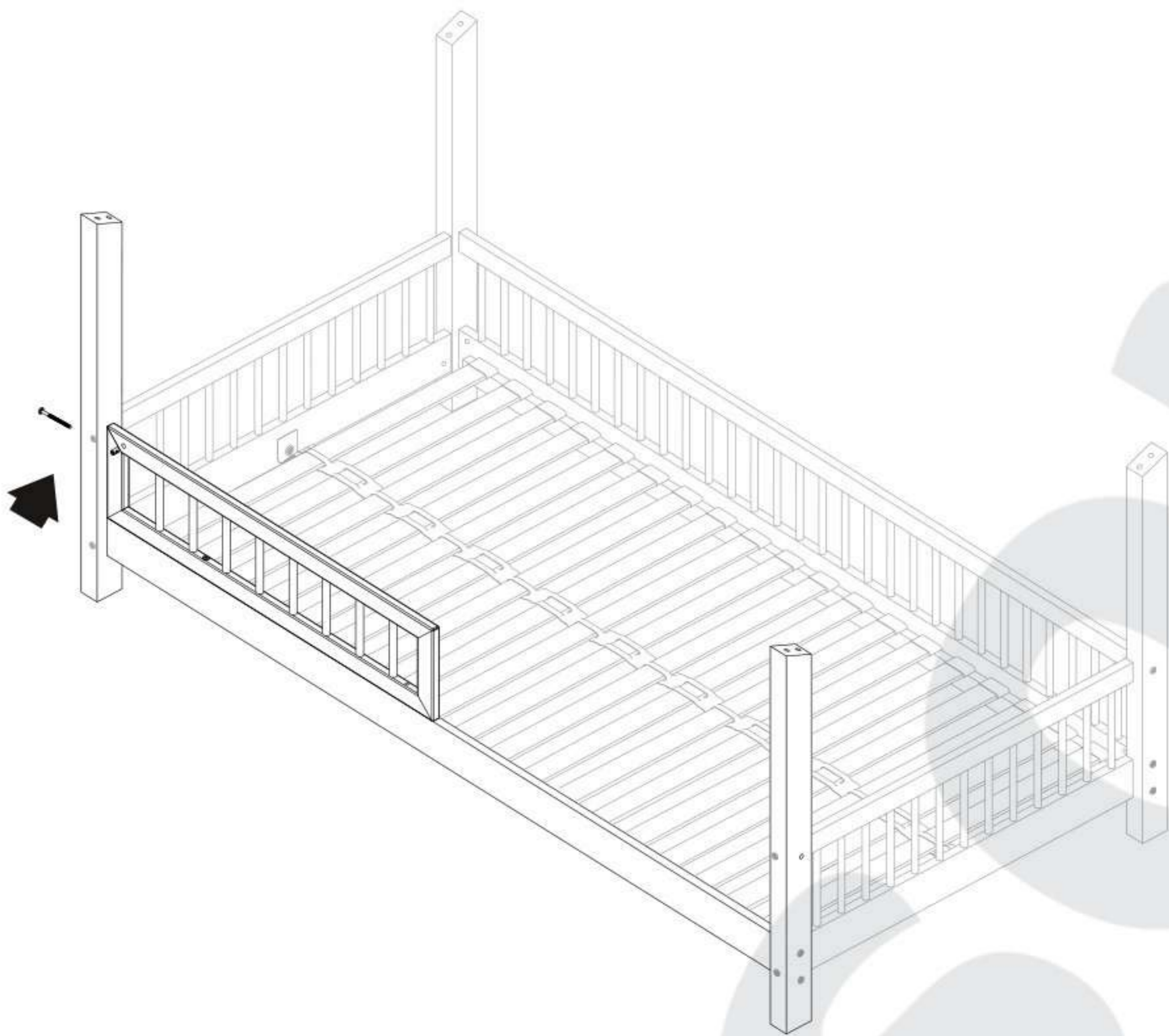
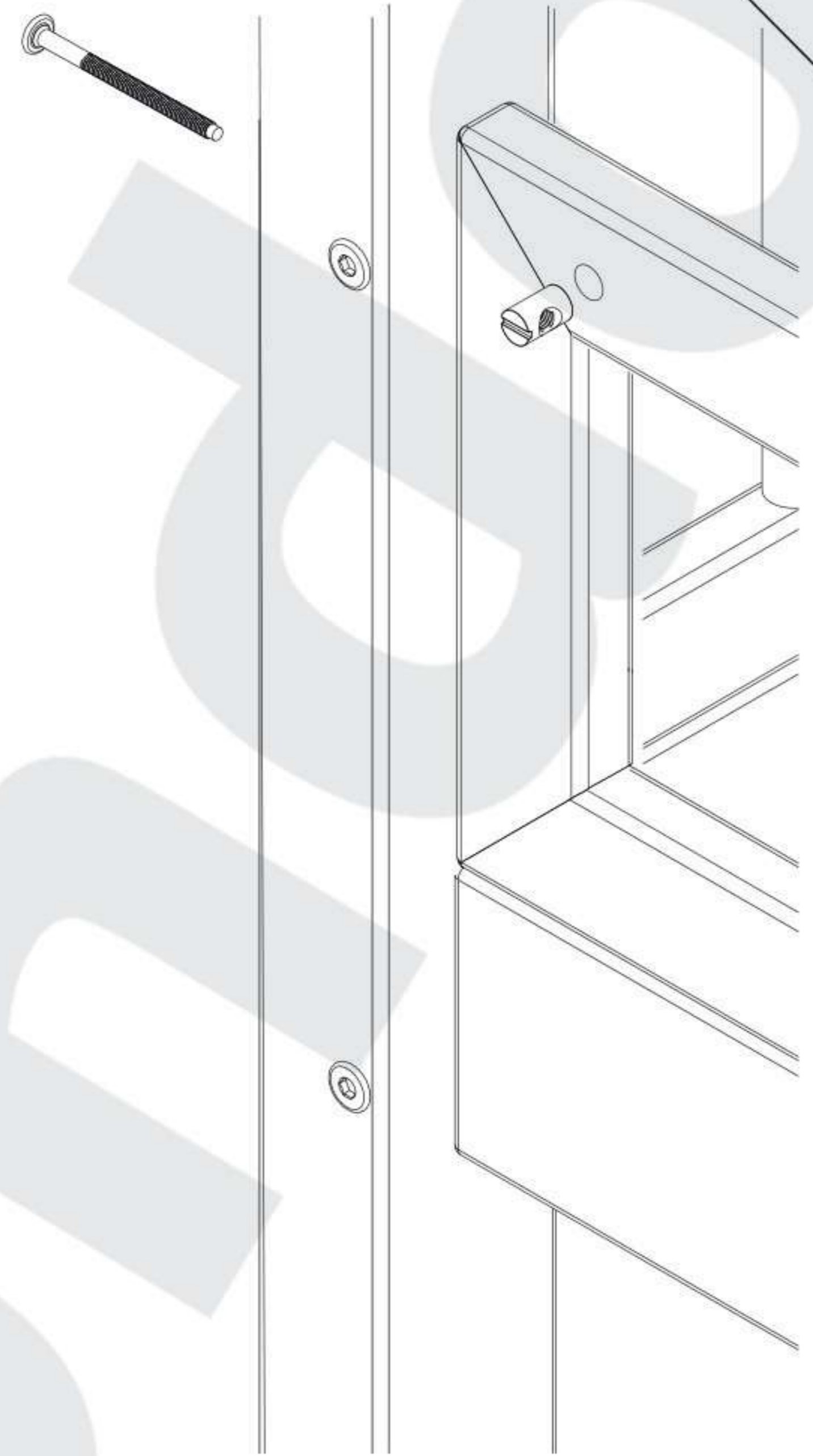
015	100	002
		
1x	1x	

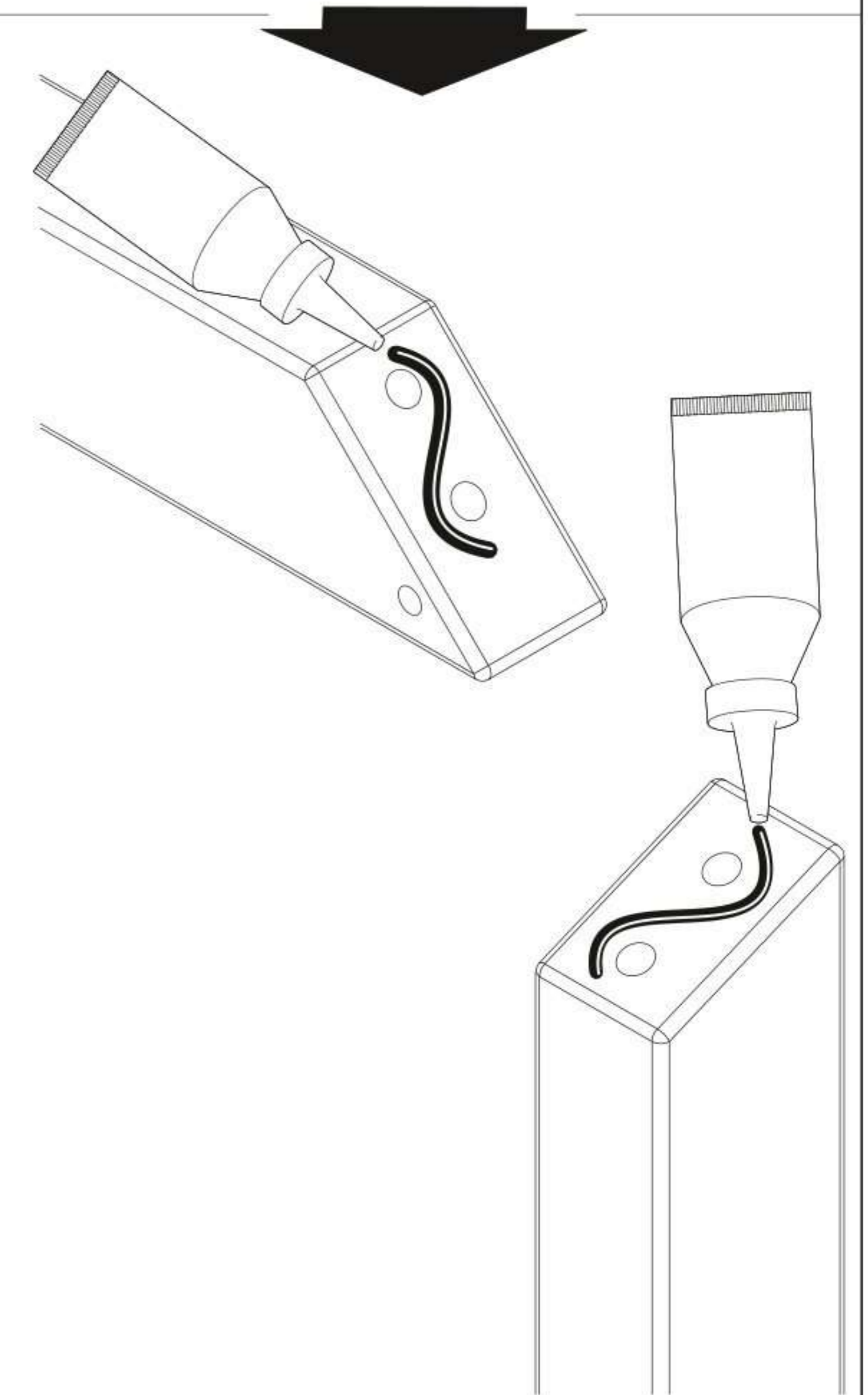
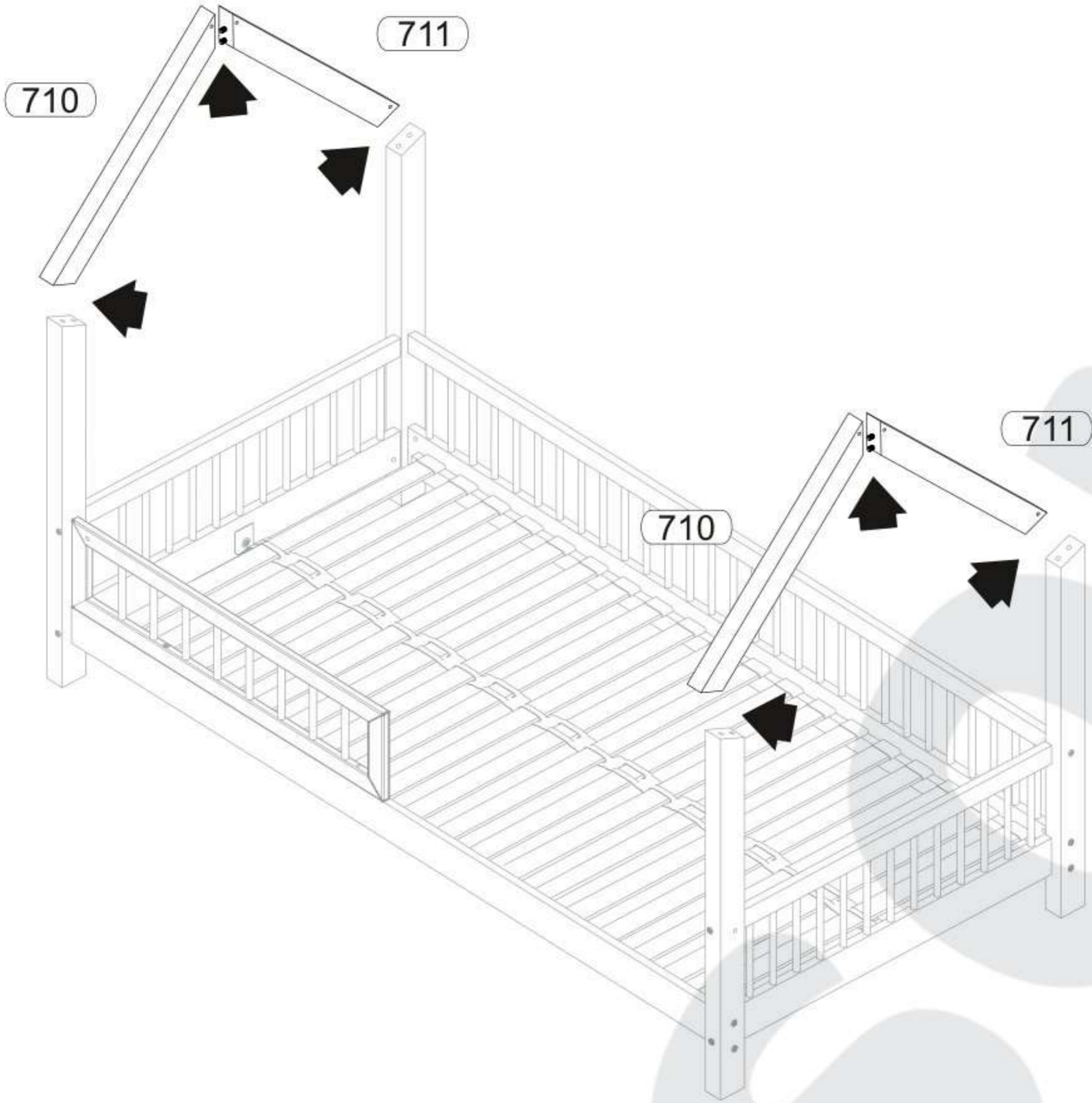
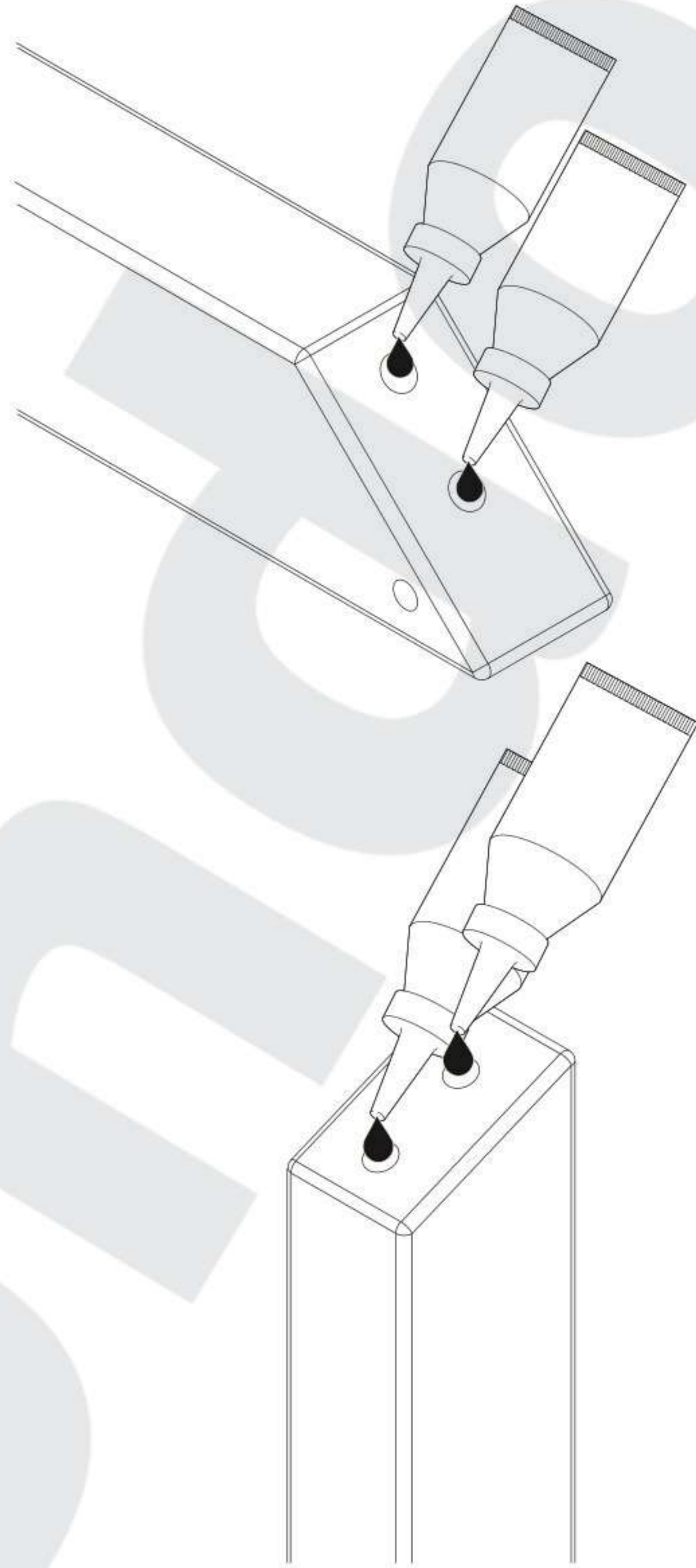
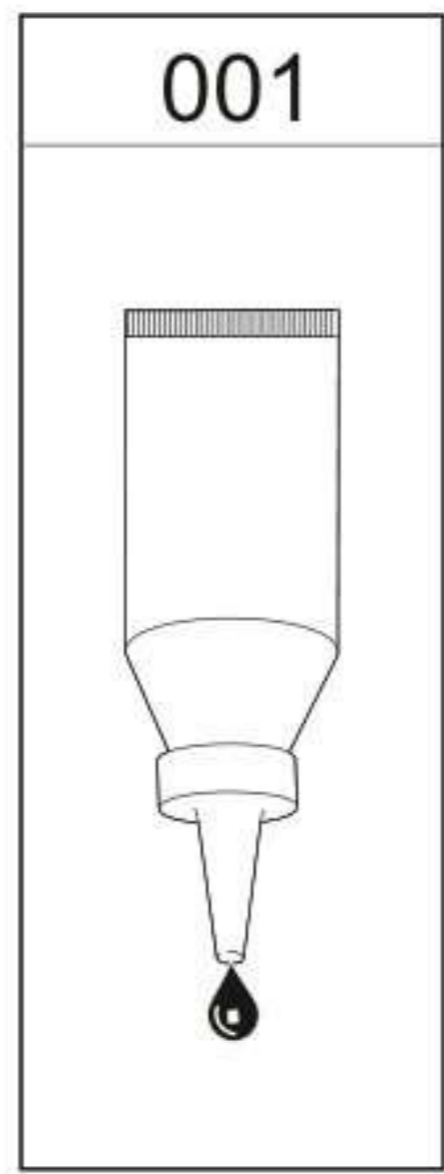

18

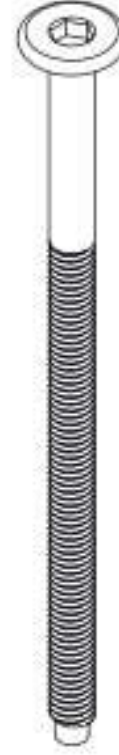

013	080	002
		
6x	6x	

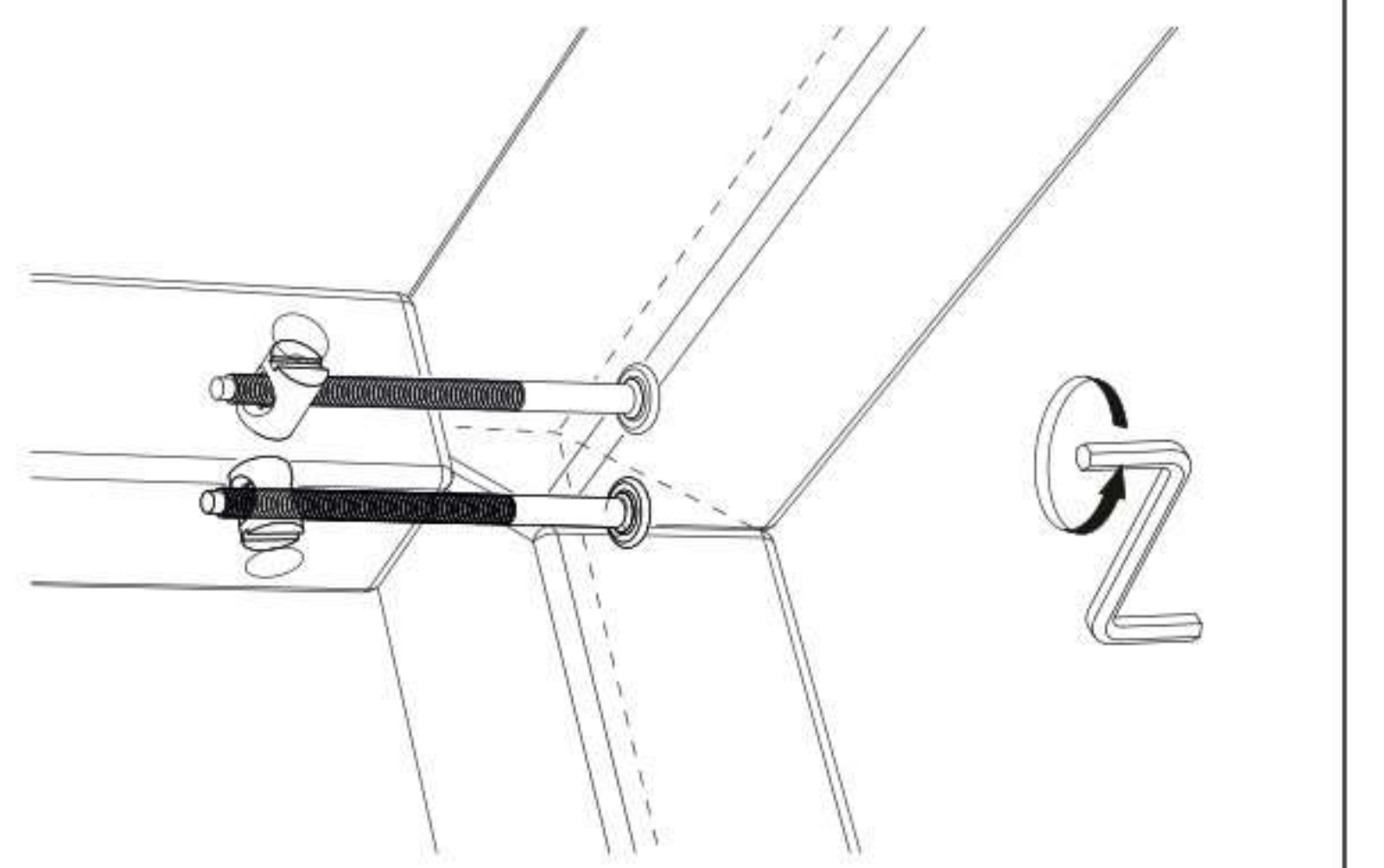
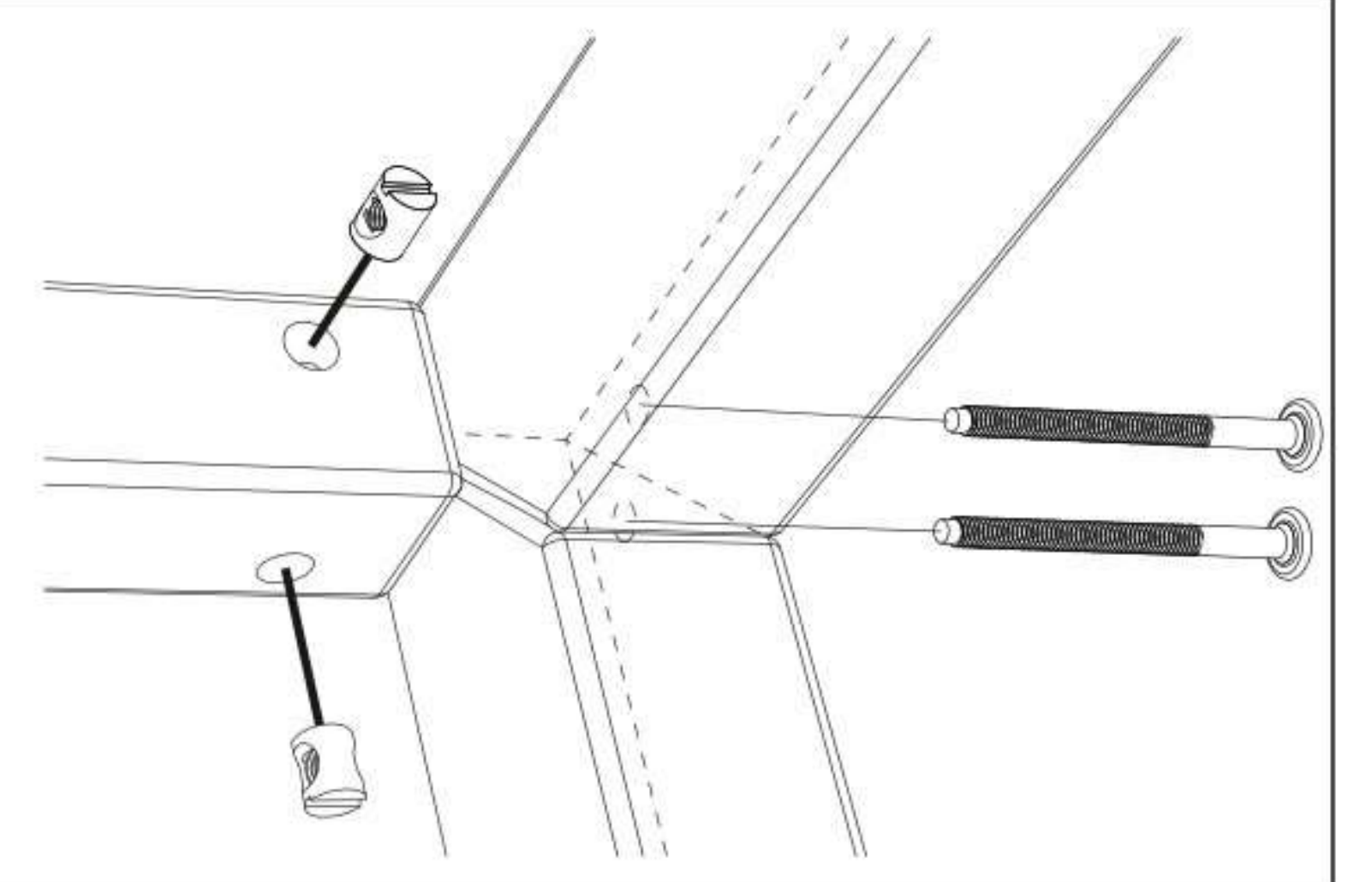
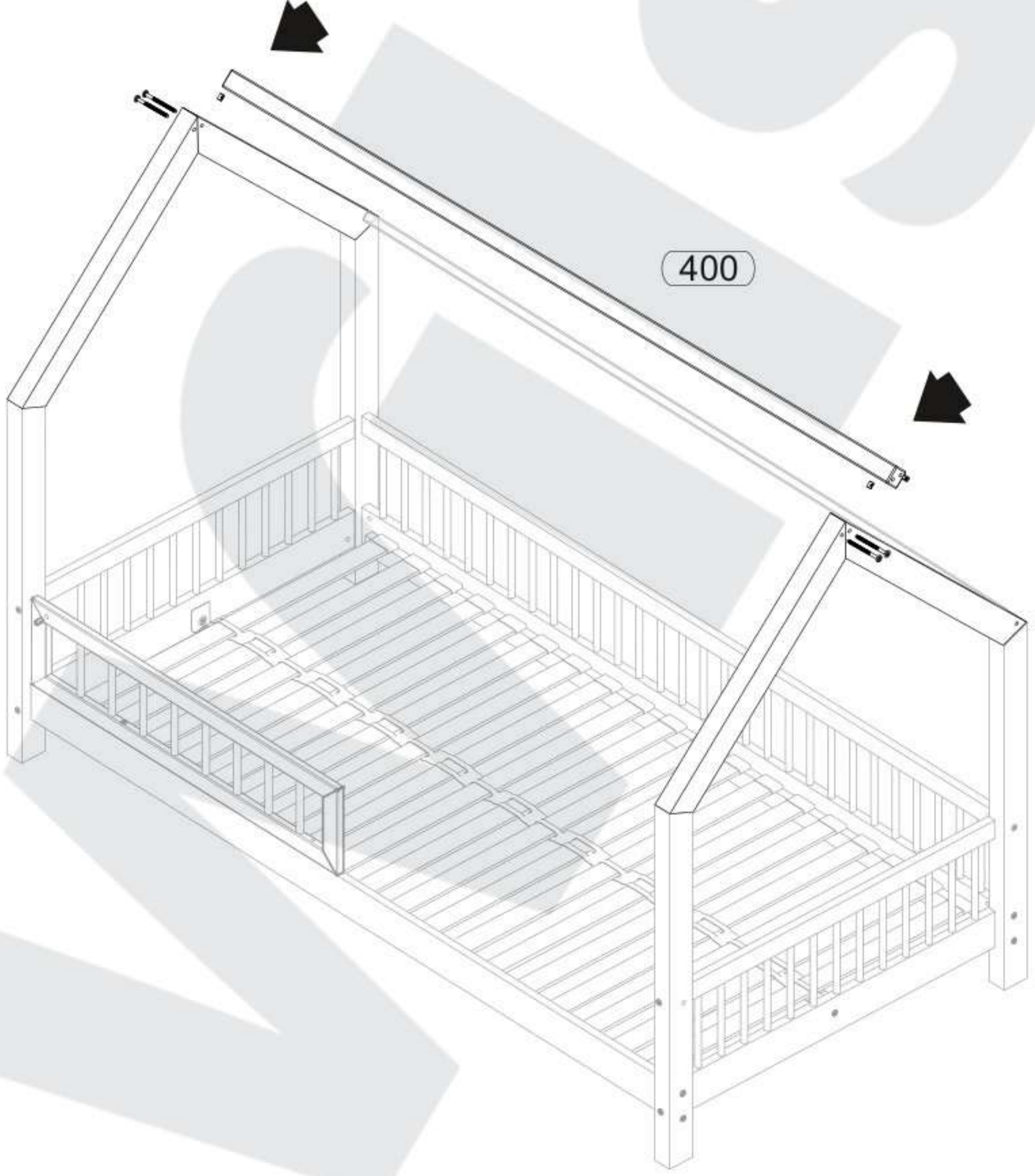
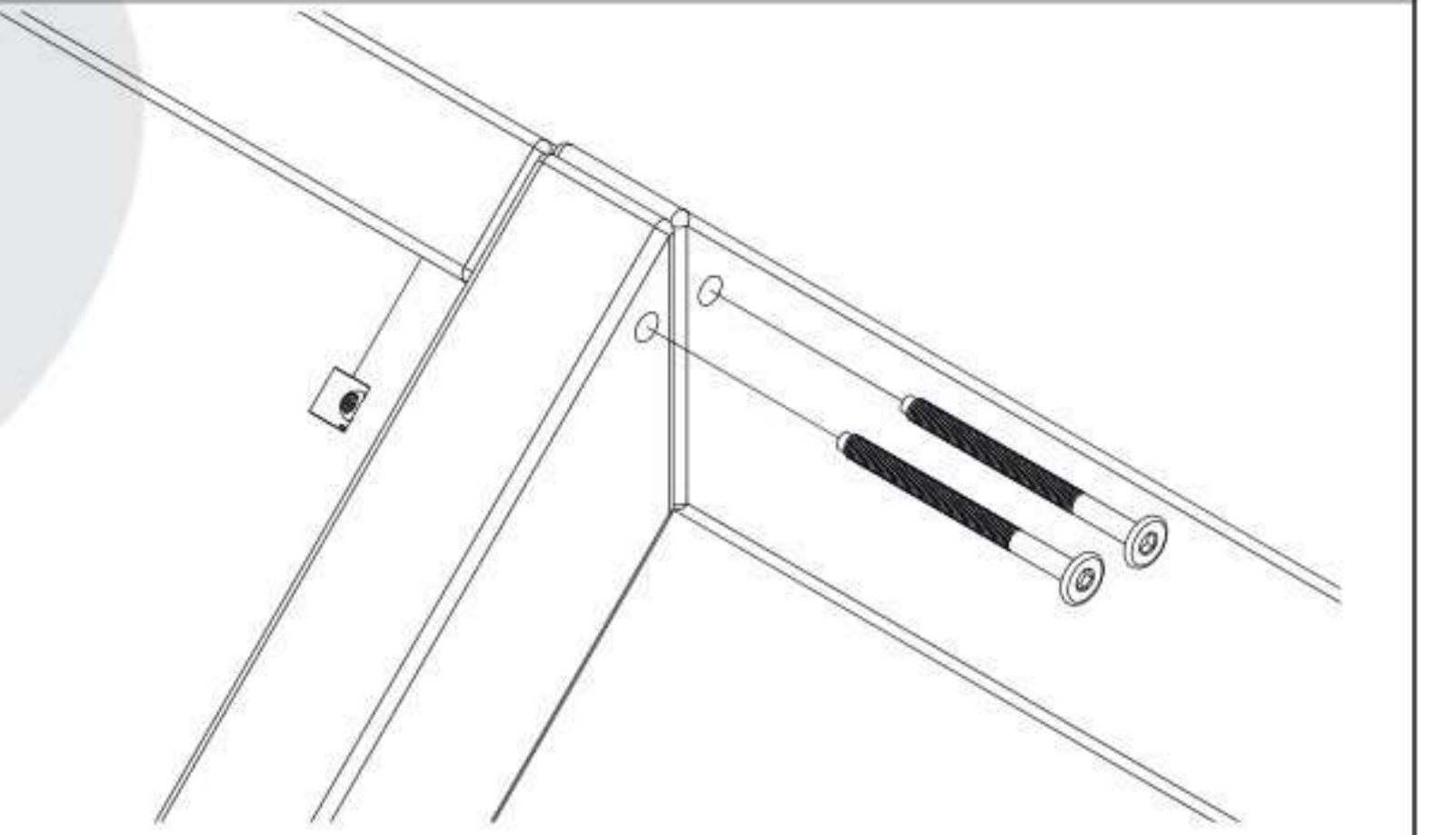
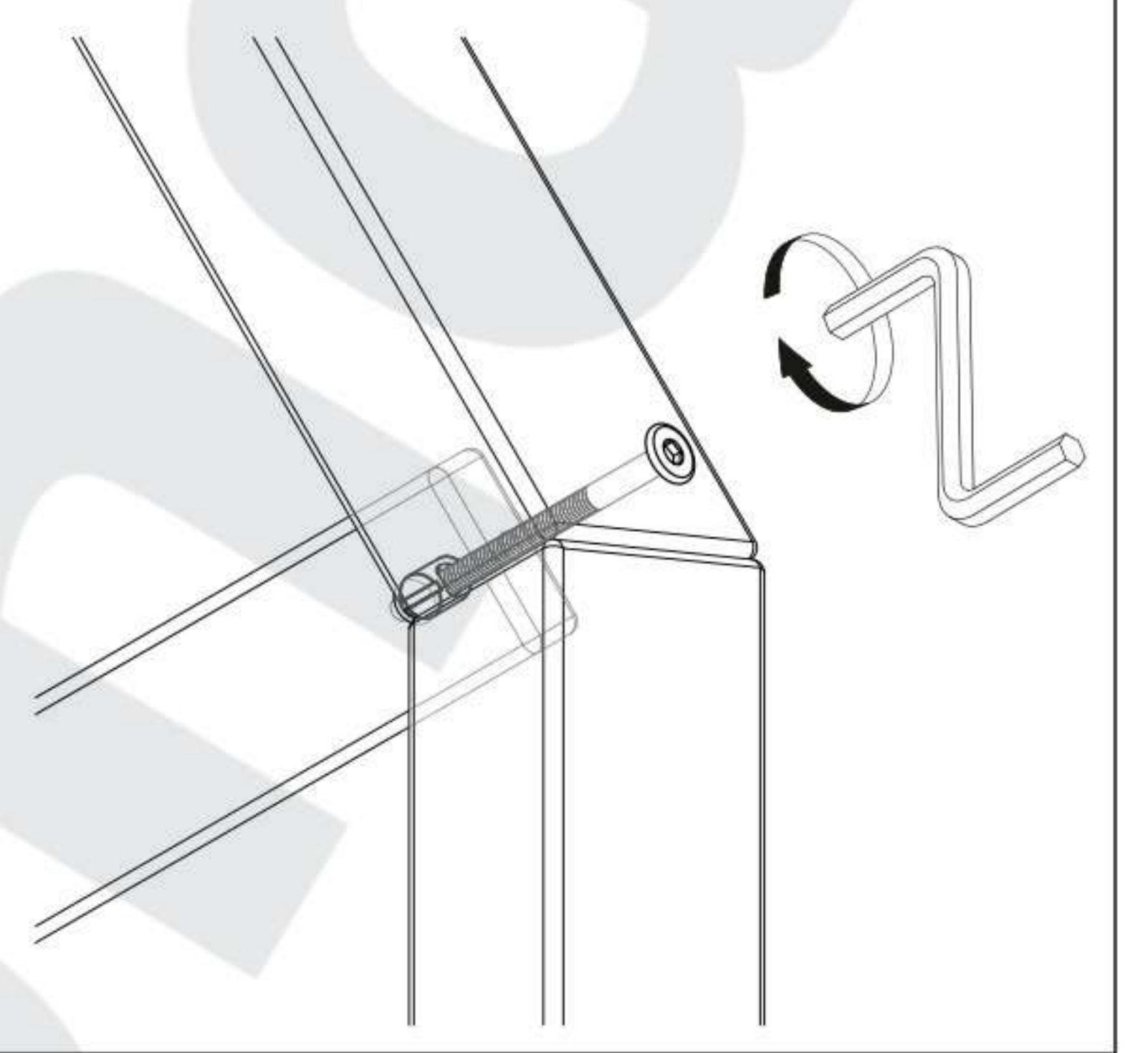
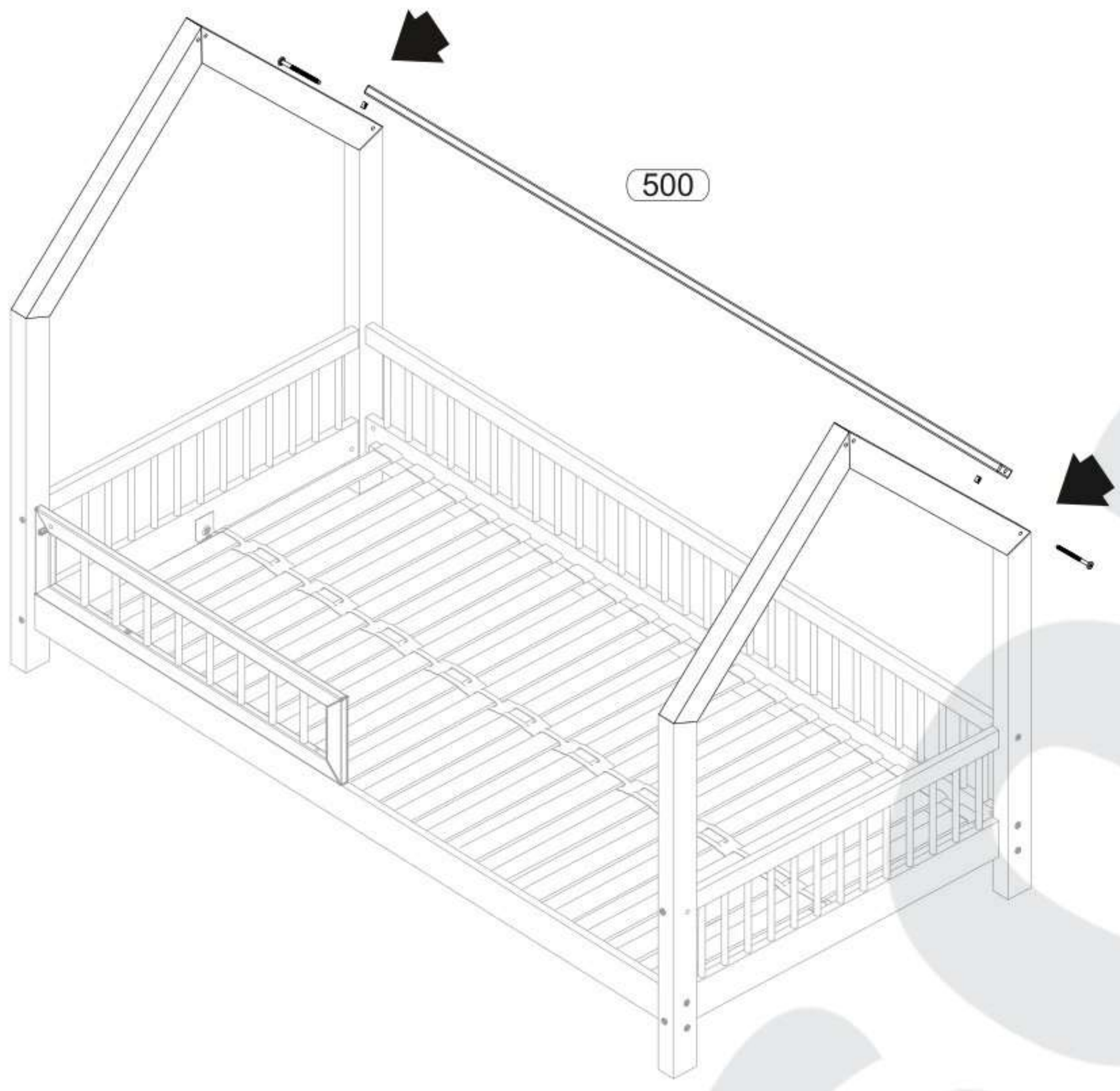
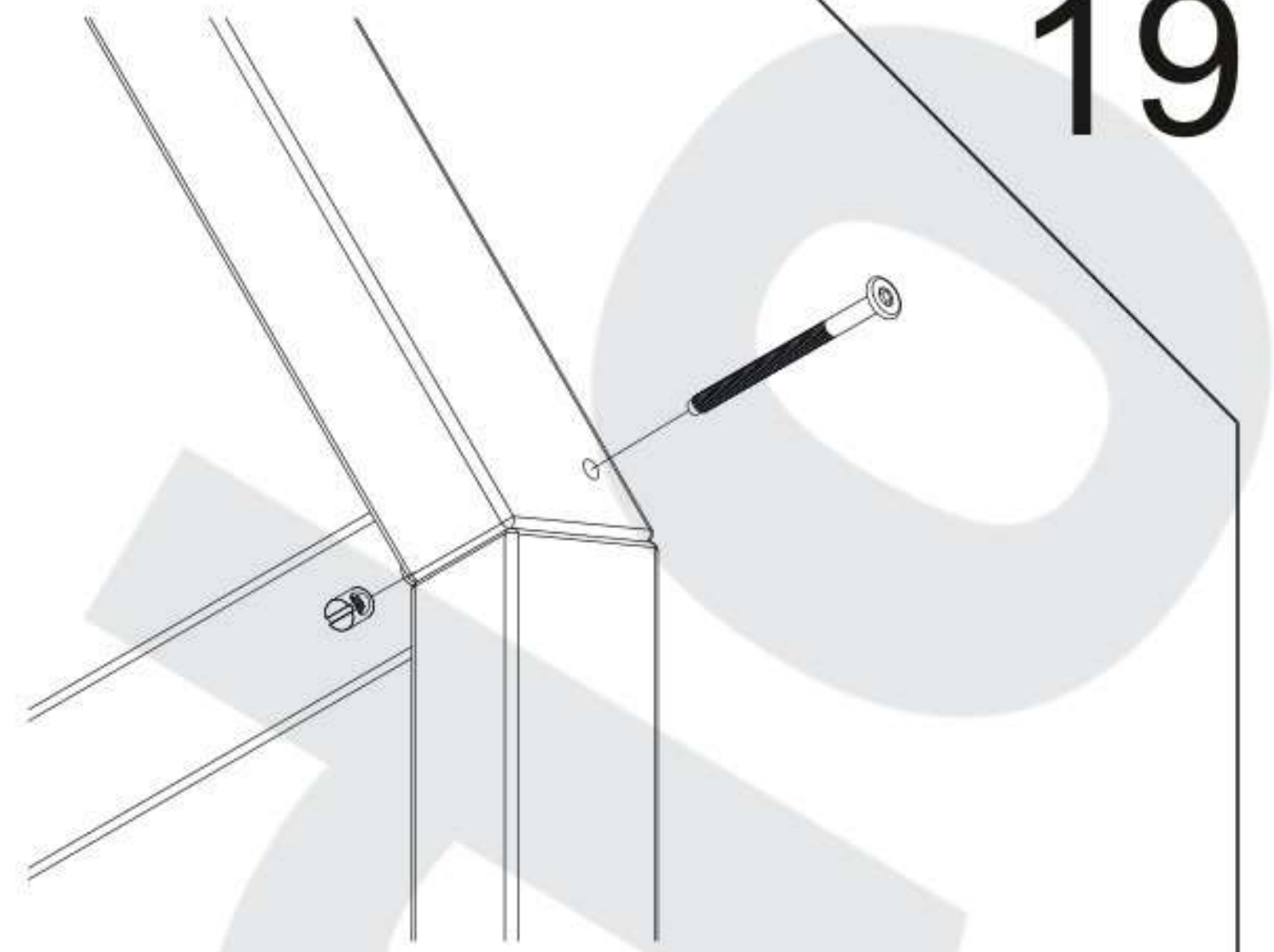

Müllsammelplan

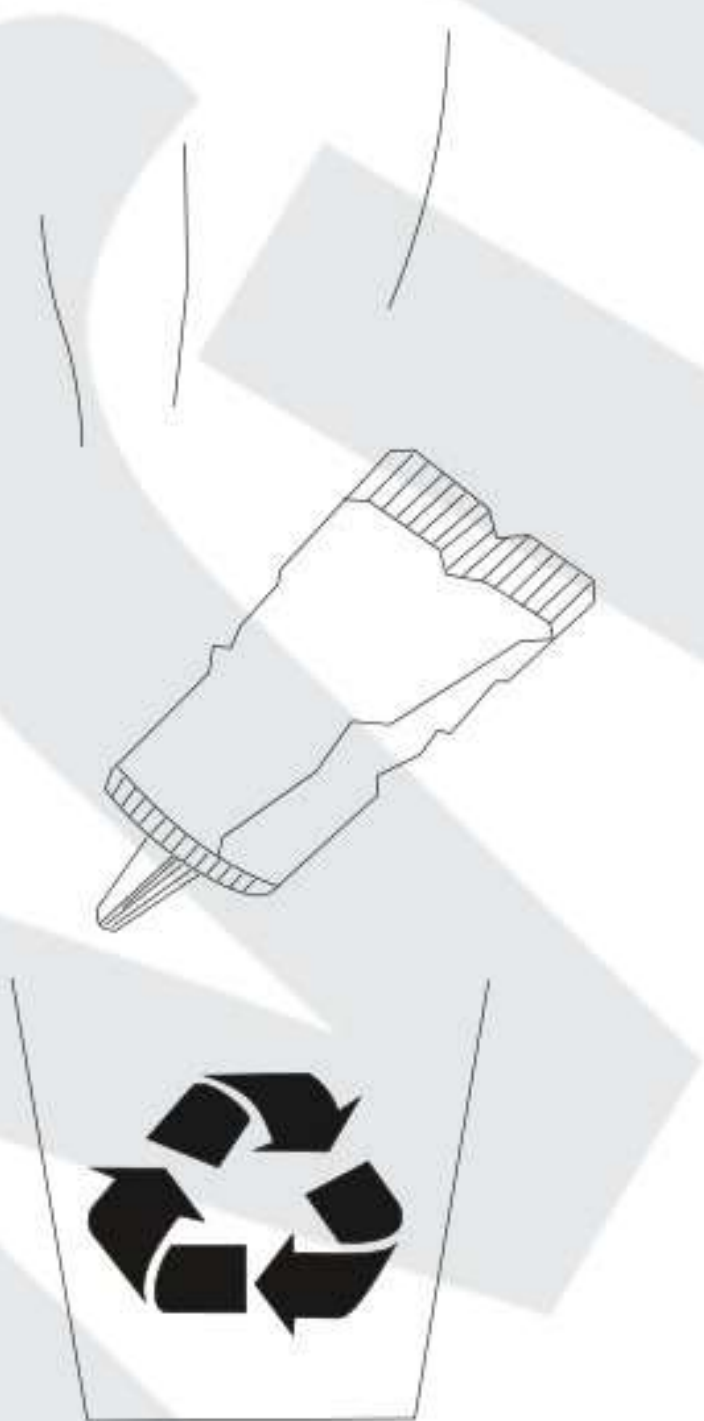

PLASTIC

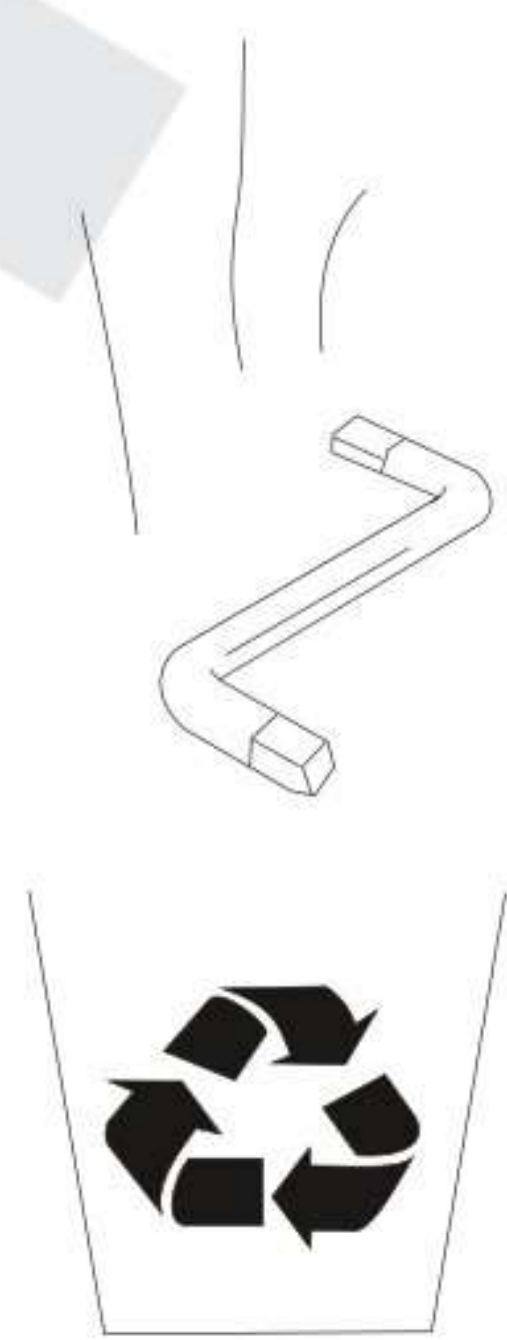

METAL

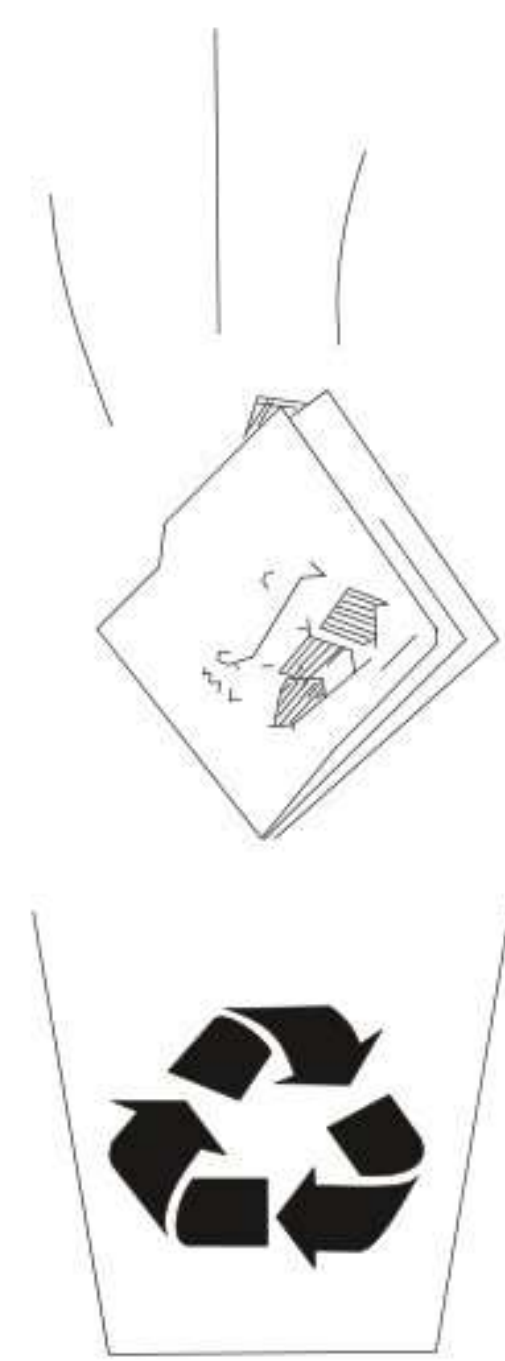

PAPER