







<ul style="list-style-type: none"> • Zalecamy nie wyrzucać opakowania dopóki nie ukończysz montażu. • Montażu najlepiej dokonać na miękkiej i czystej powierzchni, takiej jak tektura, ręcznik, koc. Uchroni to przed uszkodzeniem mebla. • Zarówno opakowania plastikowe, jak i okucia trzymać w miejscu niedostępnym dla niemowląt i dzieci. • Wszystkie połączenia powinny być odpowiednio dokręcone. • Przed przystąpieniem do montażu prosimy zapoznać się z całą instrukcją montażu. Zestaw montażowy znajduje się w opakowaniach. Prosimy dokładnie sprawdzić każdą paczkę. • Przed przystąpieniem do montażu prosimy sprawdzić czy nie brakuje żadnych elementów. 	
<ul style="list-style-type: none"> • We recommend not discarding the packaging until you have completed the assembly. • It is best to perform the assembly on a soft and clean surface, such as cardboard, a towel, or a blanket. This will protect the furniture from damage. • Keep both plastic packaging and fittings out of reach of infants and children. • All connections should be properly tightened. • Please familiarize yourself with the entire assembly instructions before starting the assembly. • The assembly kit is located in the packaging. Please thoroughly check each package. • Before starting the assembly, please check if any elements are missing. 	
<ul style="list-style-type: none"> • Wir empfehlen, die Verpackung nicht zu entsorgen, bis Sie die Montage abgeschlossen haben. • Die Montage erfolgt am besten auf einer weichen und sauberen Oberfläche wie Karton, einem Handtuch oder einer Decke. Dadurch wird das Möbel vor Beschädigungen geschützt. • Halten Sie sowohl Kunststoffverpackungen als auch Beschläge außerhalb der Reichweite von Säuglingen und Kindern. • Alle Verbindungen sollten ordnungsgemäß festgezogen werden. • Bitte lesen Sie vor Beginn der Montage die gesamte Montageanleitung. • Das Montageset befindet sich in den Verpackungen. Bitte überprüfen Sie jede Packung sorgfältig. • Bevor Sie mit der Montage beginnen, überprüfen Sie bitte, ob keine Elemente fehlen. 	
<ul style="list-style-type: none"> • Doporučujeme nevyhazovat obal, dokud nedokončíte montáž. • Montáž je nejlépe provést na měkkém a čistém povrchu, jako je karton, ručník nebo deka. Tím se zabrání poškození nábytku. • Plastové obaly i kování uchovávejte mimo dosah kojenců a dětí. • Všechny spoje by měly být správně utaženy. • Před zahájením montáže si prosím přečtete celý montážní návod. • Montážní sada se nachází v obalech. Prosím pečlivě zkontrolujte každý balíček. • Před zahájením montáže si prosím ověřte, zda nechybí žádné prvky. 	
<ul style="list-style-type: none"> • Odporučame neprehadzovať obal, kým nedokončíte montáž. • Montáž je najlepšie vykonať na mäkkom a čistom povrchu, ako je kartón, uterák alebo deka. Tým sa predíde poškodeniu nábytku. • Plastové obaly aj kovania uchovávejte mimo dosahu dojčiat a detí. • Všetky spoje by mali byť správne dotiahnuté. • Pred začatím montáže sa prosím oboznámte s celým montážnym návodom. • Montážny set sa nachádza v obaloch. Prosím dôkladne skontrolujte každý balík. • Pred začatím montáže prosím skontrolujte, či nechýbajú žiadne časti. 	
<ul style="list-style-type: none"> • Vă recomandăm să nu aruncați ambalajul până când nu ați terminat asamblarea. • Este mai bine să asamblați pe o suprafață moale și curată, cum ar fi carton, un prosop sau o pătură. Acest lucru va proteja mobilierul de deteriorare. • Păstrați atât ambalajele din plastic, cât și elementele de fixare în afara accesului copiilor și sugarilor. • Toate conexiunile trebuie să fie strânse corespunzător. • Vă rugăm să vă familiarizați cu întreaga instrucțiune de asamblare înainte de a începe asamblarea. • Setul de asamblare se află în ambalaje. Vă rugăm să verificați cu atenție fiecare pachet. • Înainte de a începe asamblarea, vă rugăm să verificați dacă nu lipsesc elemente. 	



A	B	C	D	E	F	G	H	I	J
86x	32x	50mm 8x	32x	1x	4x16 34x	1x	1x	1x	1x
K	L	M	N	O	P	R	S	T	U
1x	6x	4x	2x	1x	3,5x16 34x	4x	40mm 6x	20x	2x

1

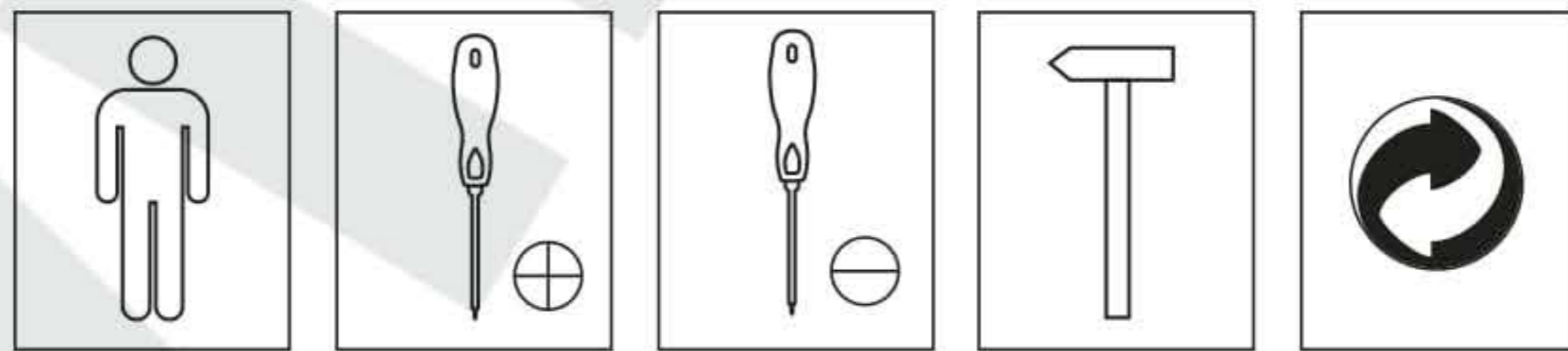
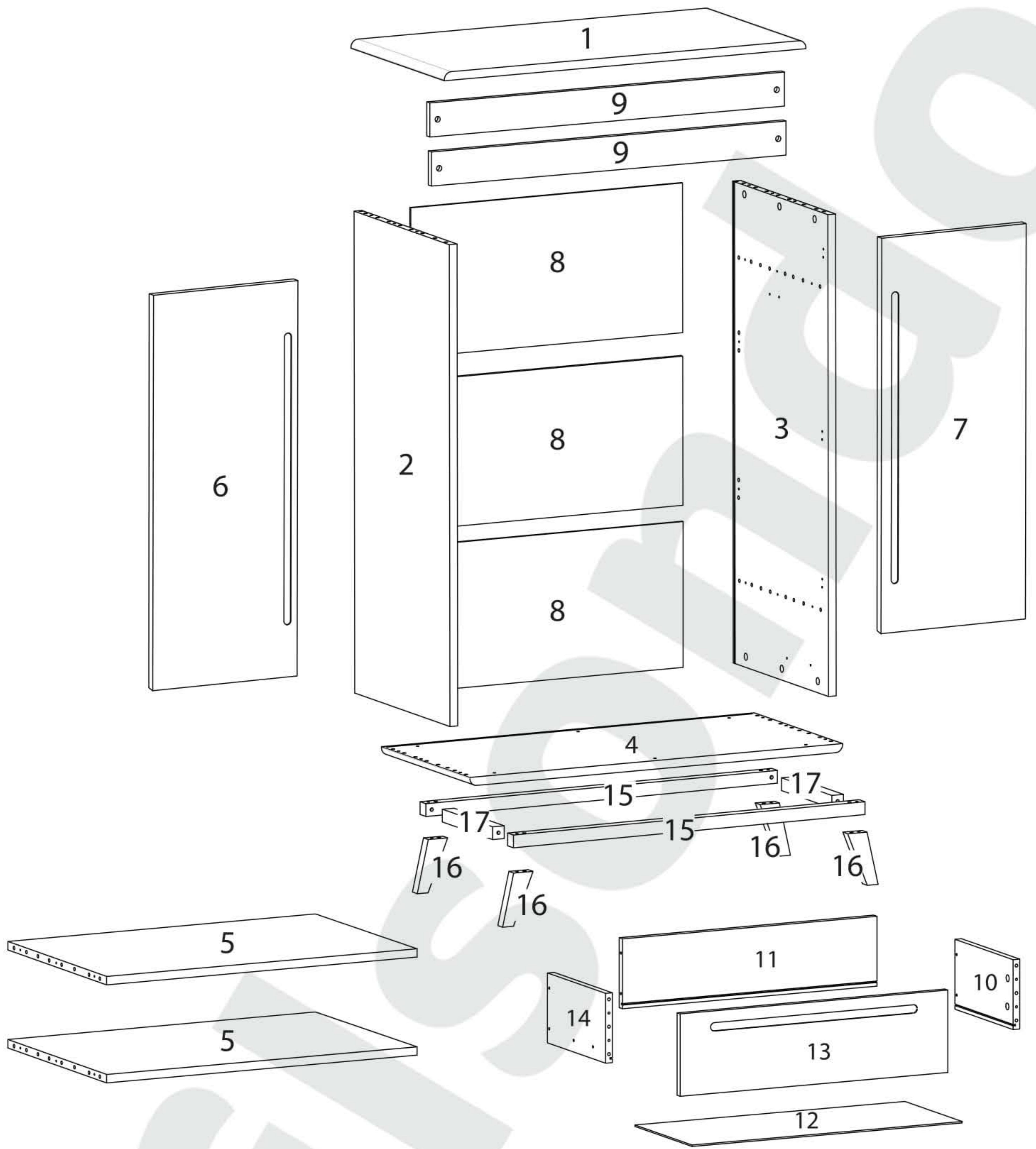
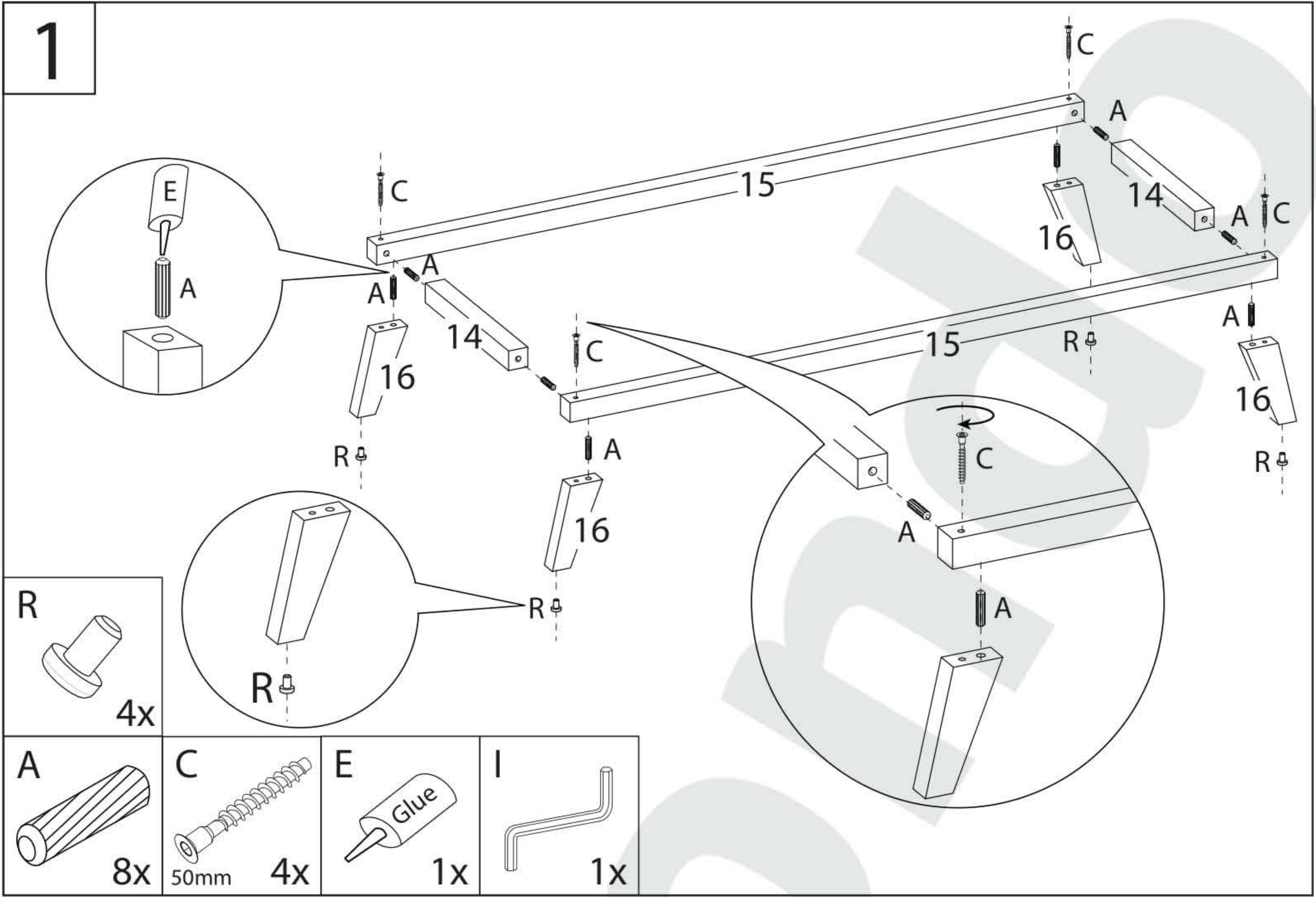

2

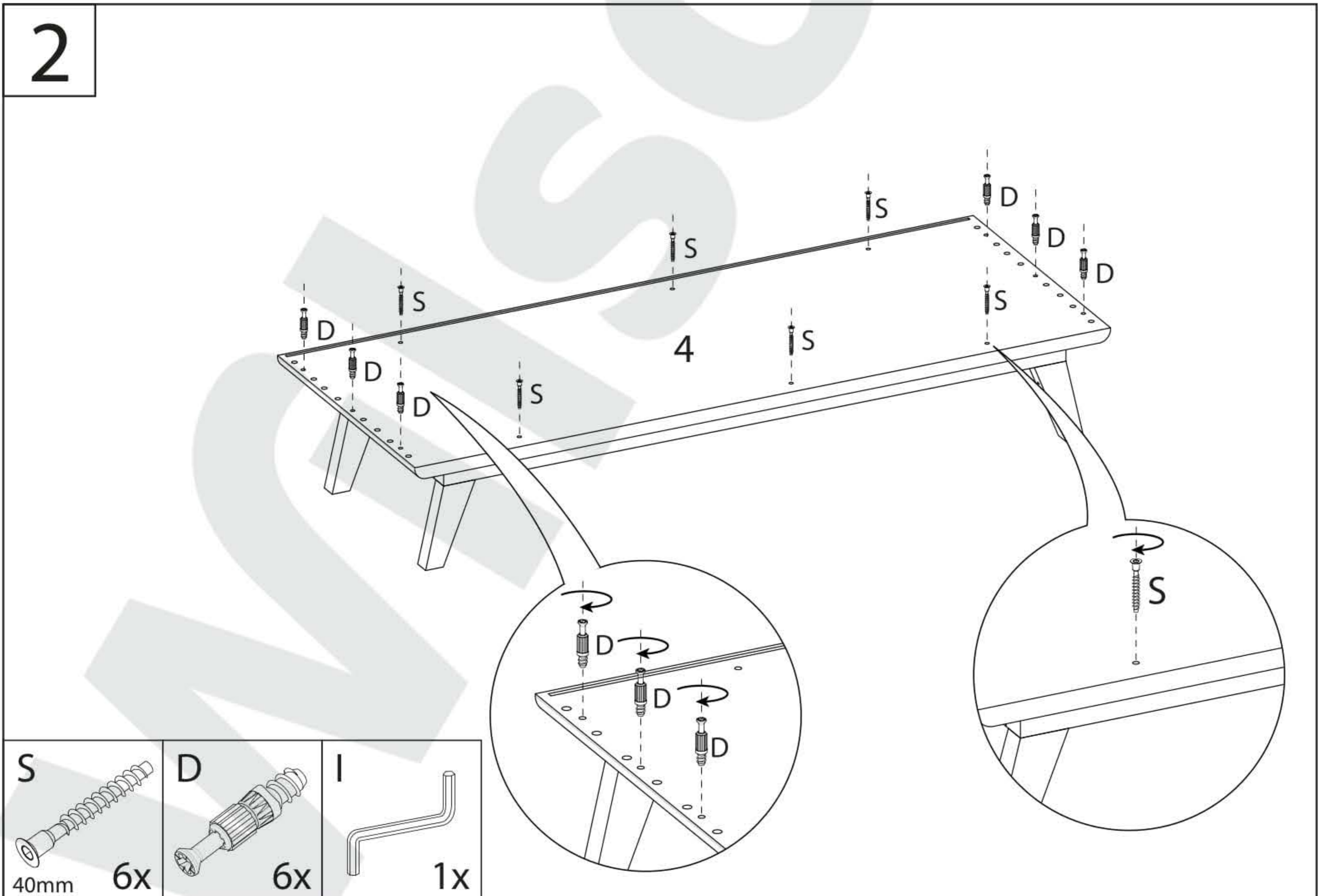

3

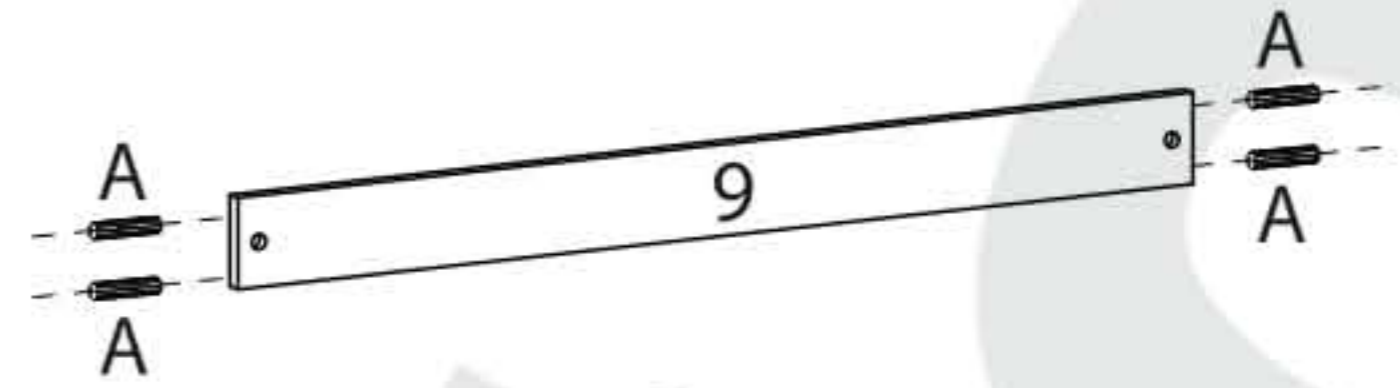
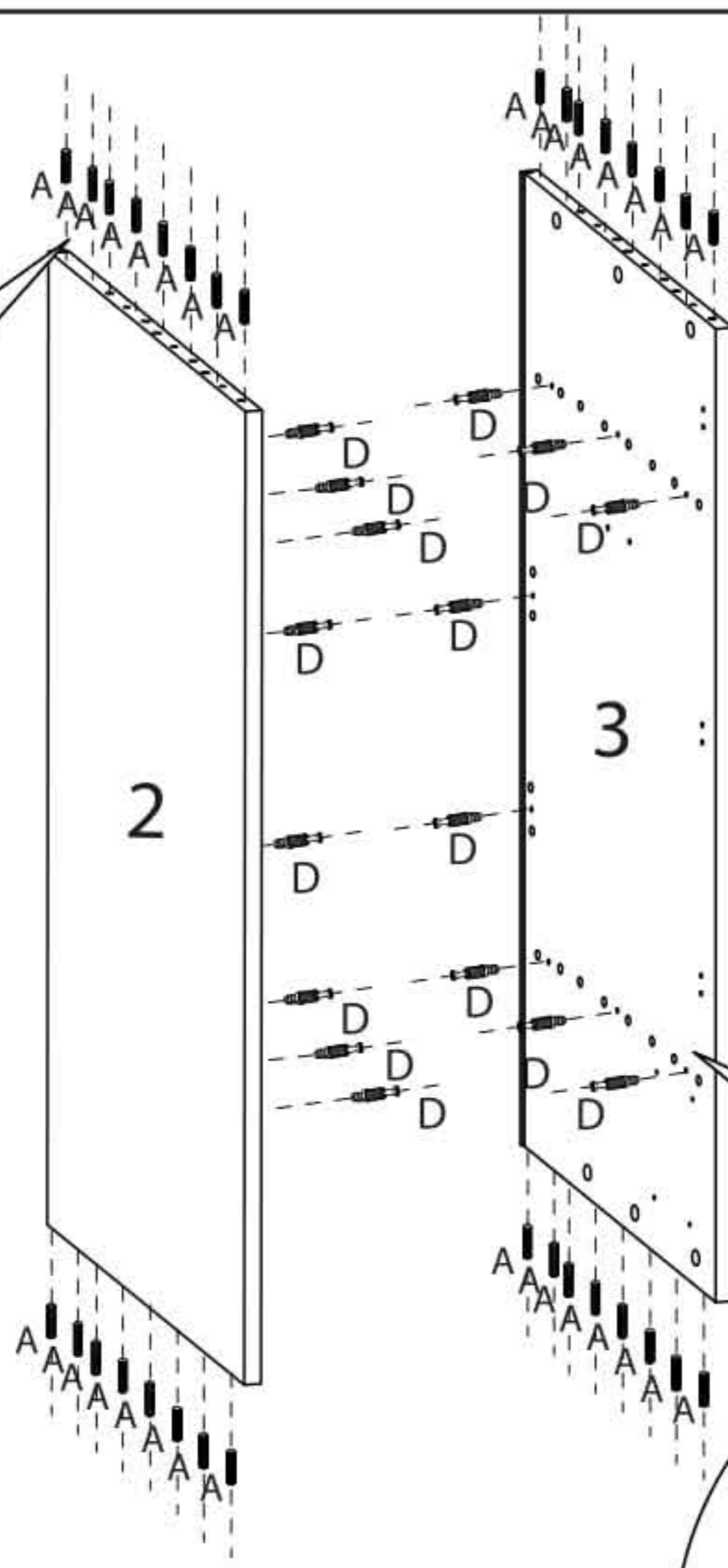
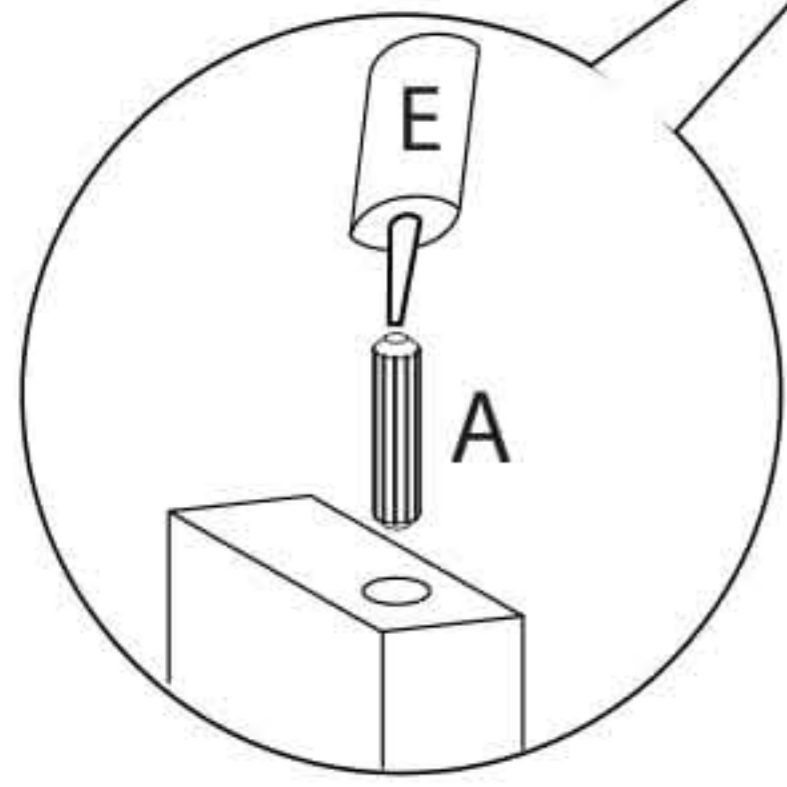

2x

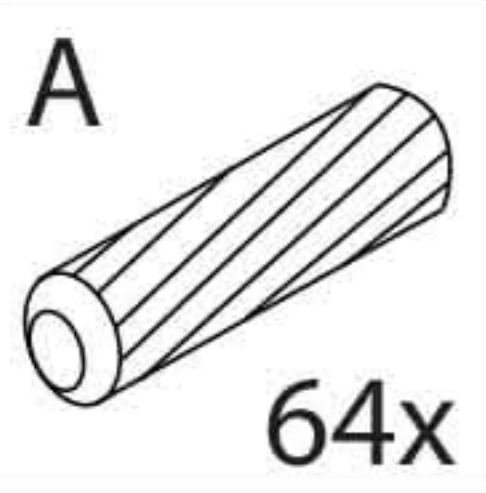
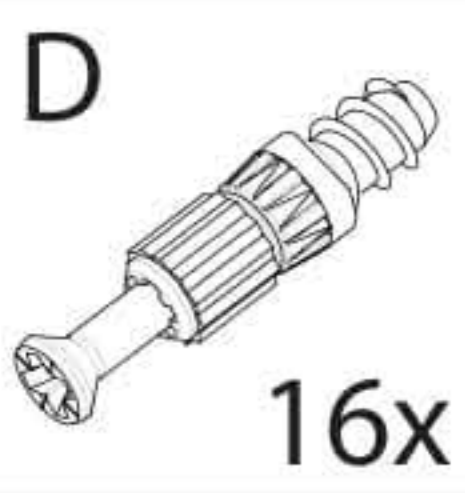
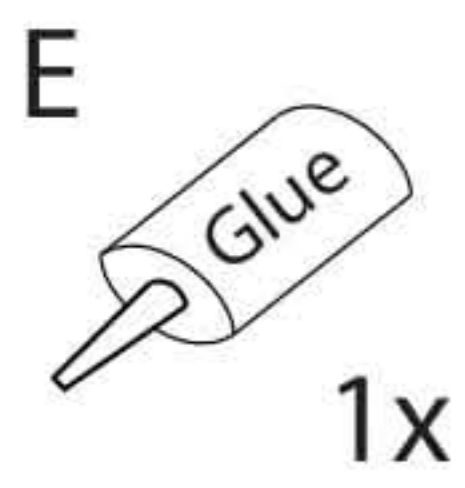
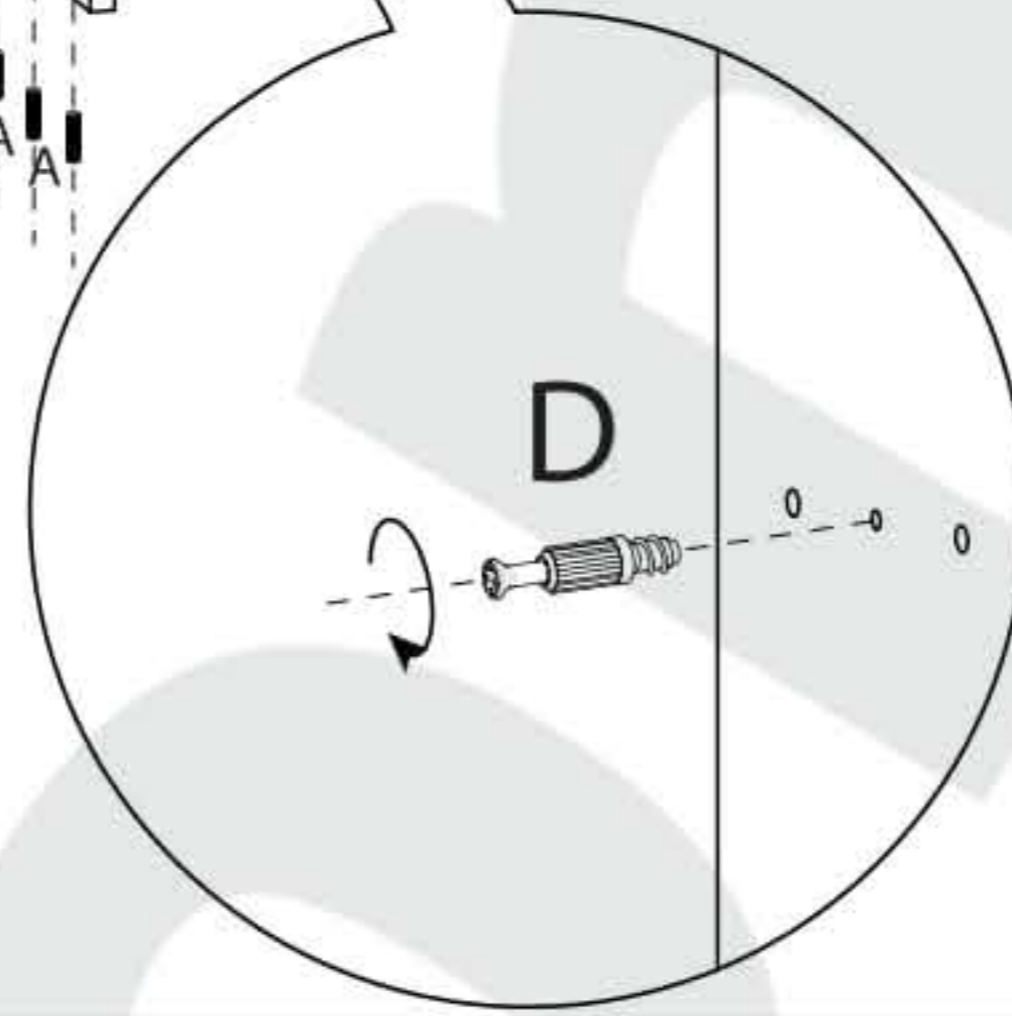
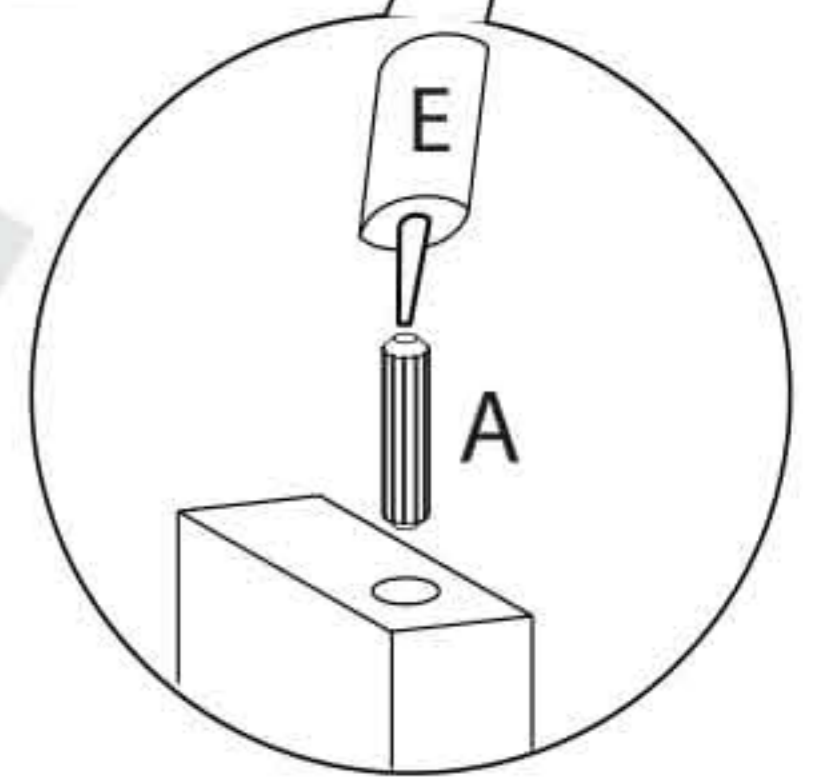
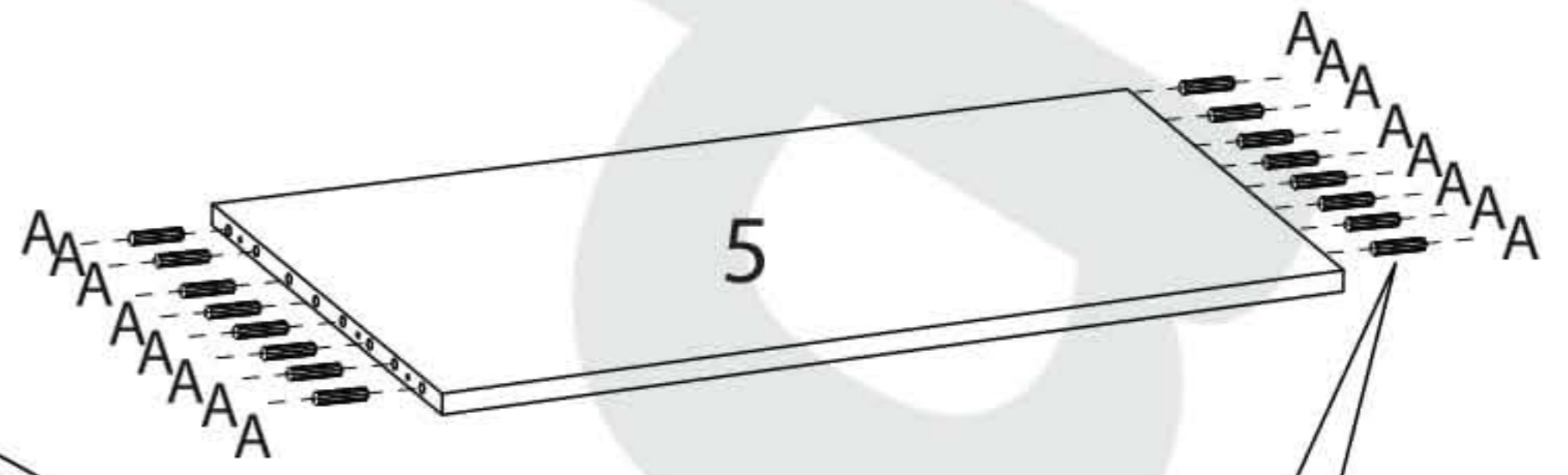

4

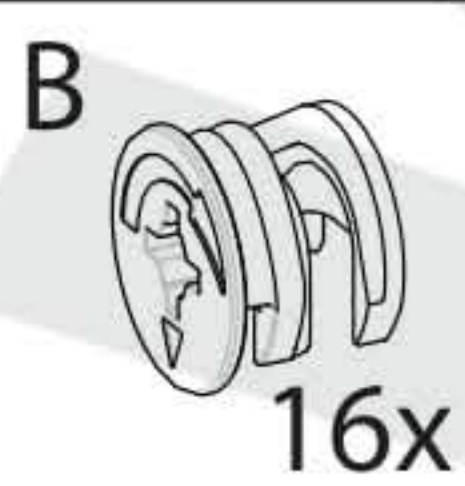
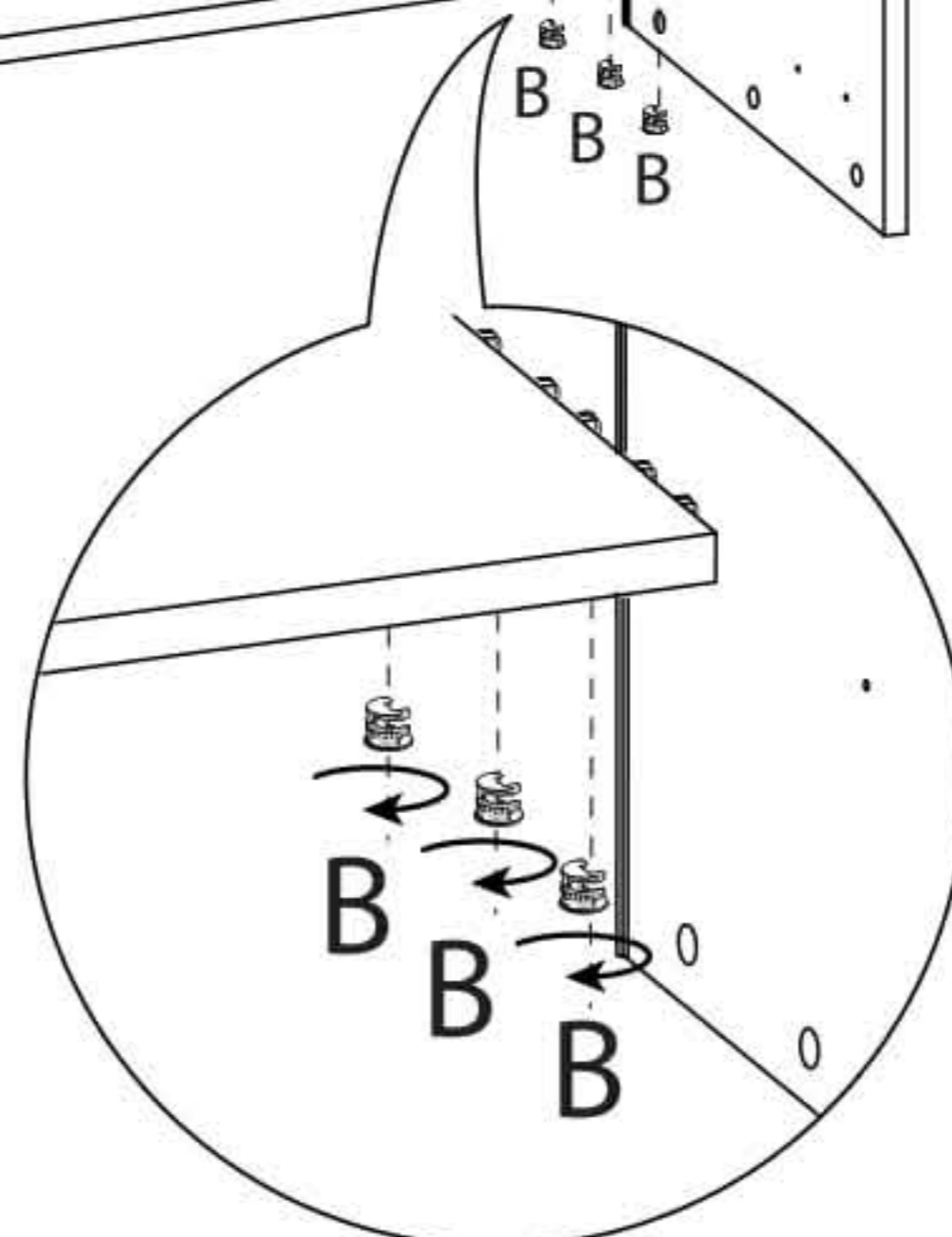
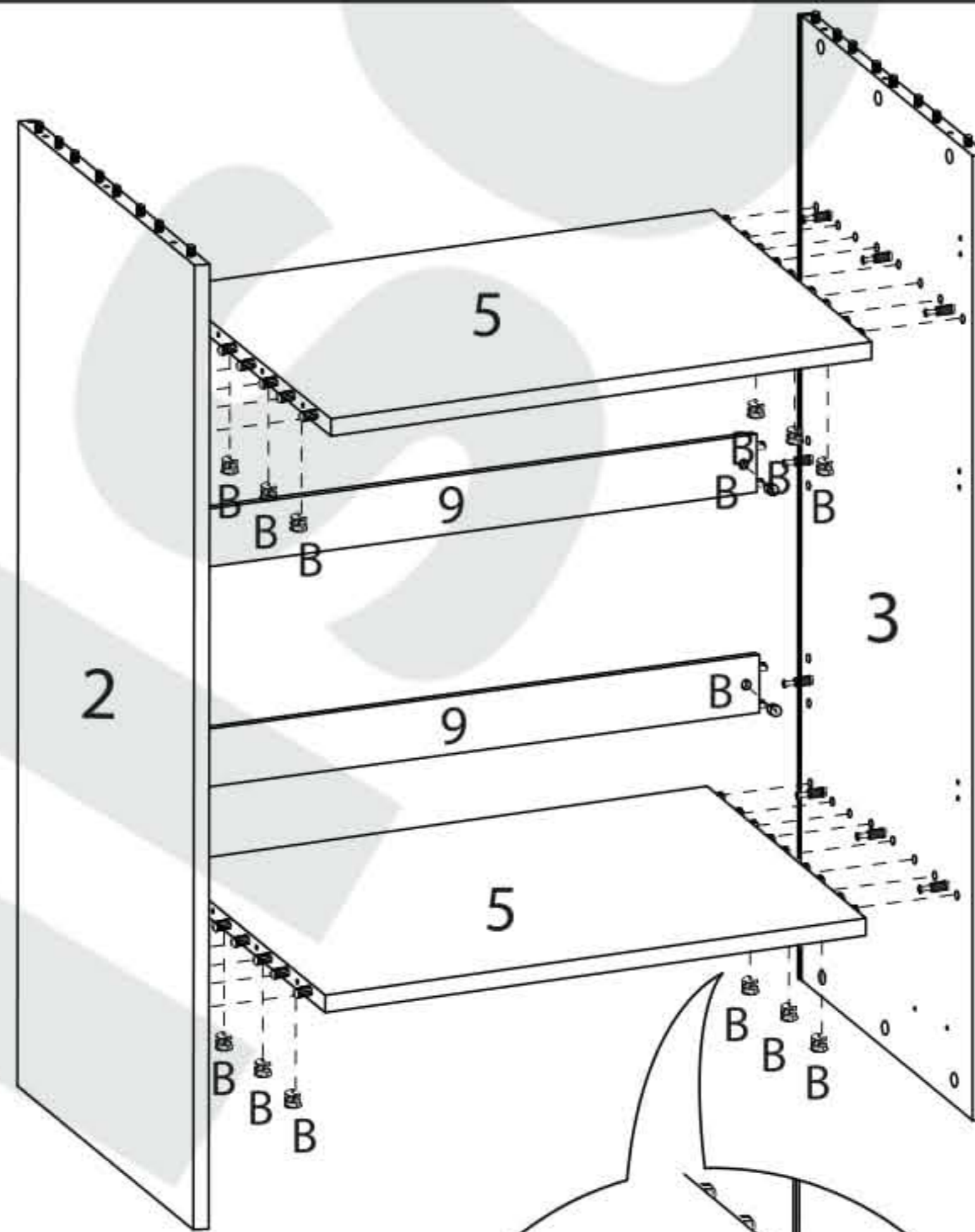

5

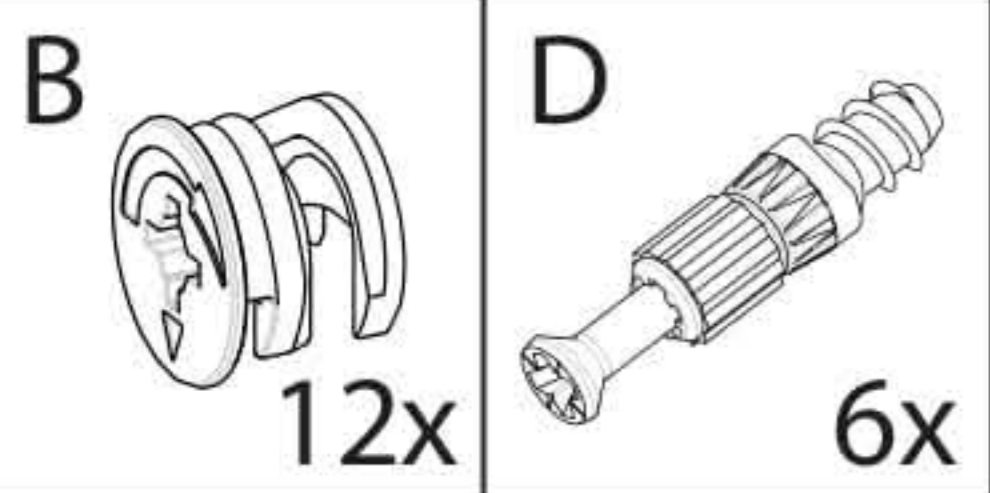
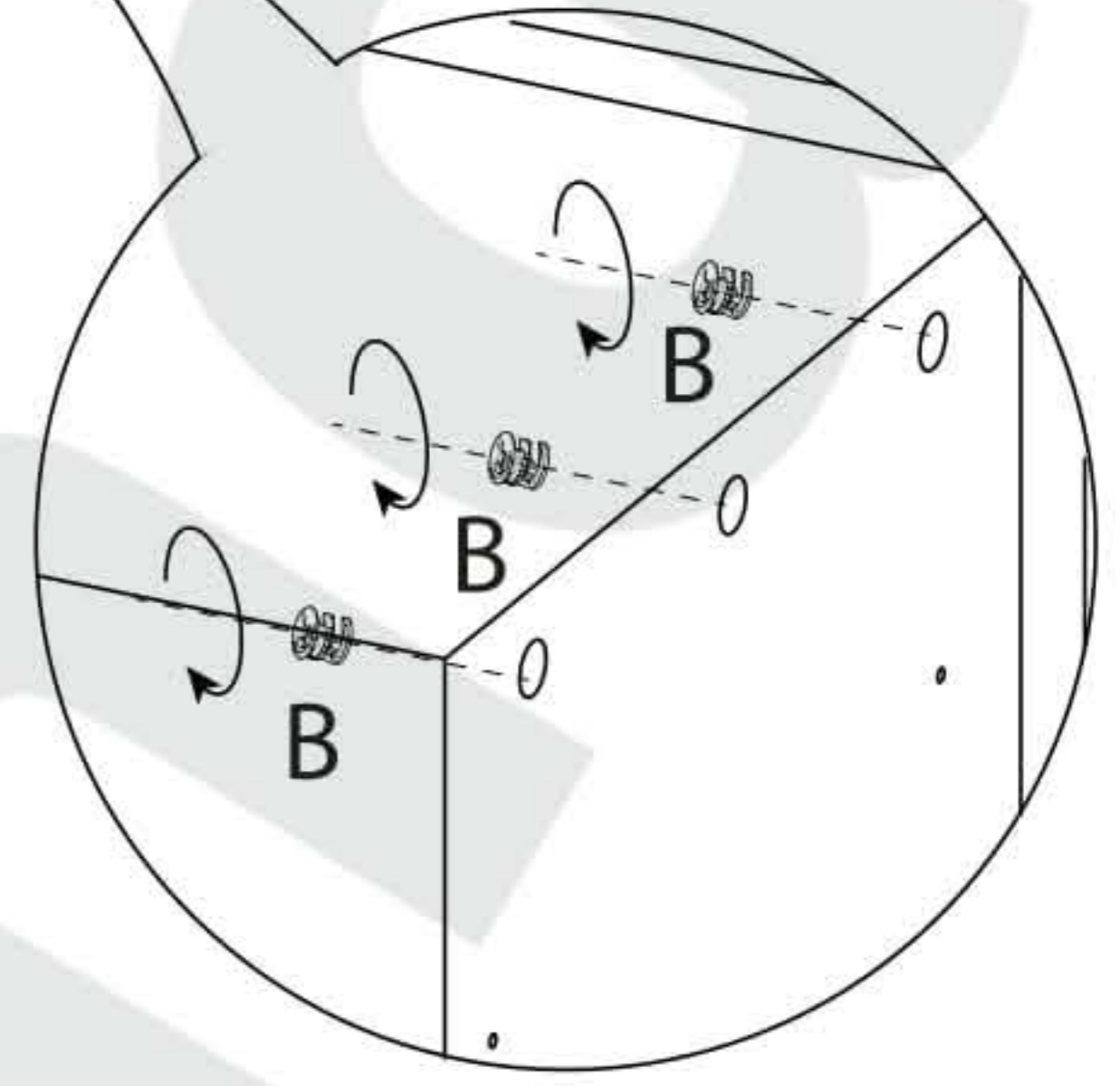
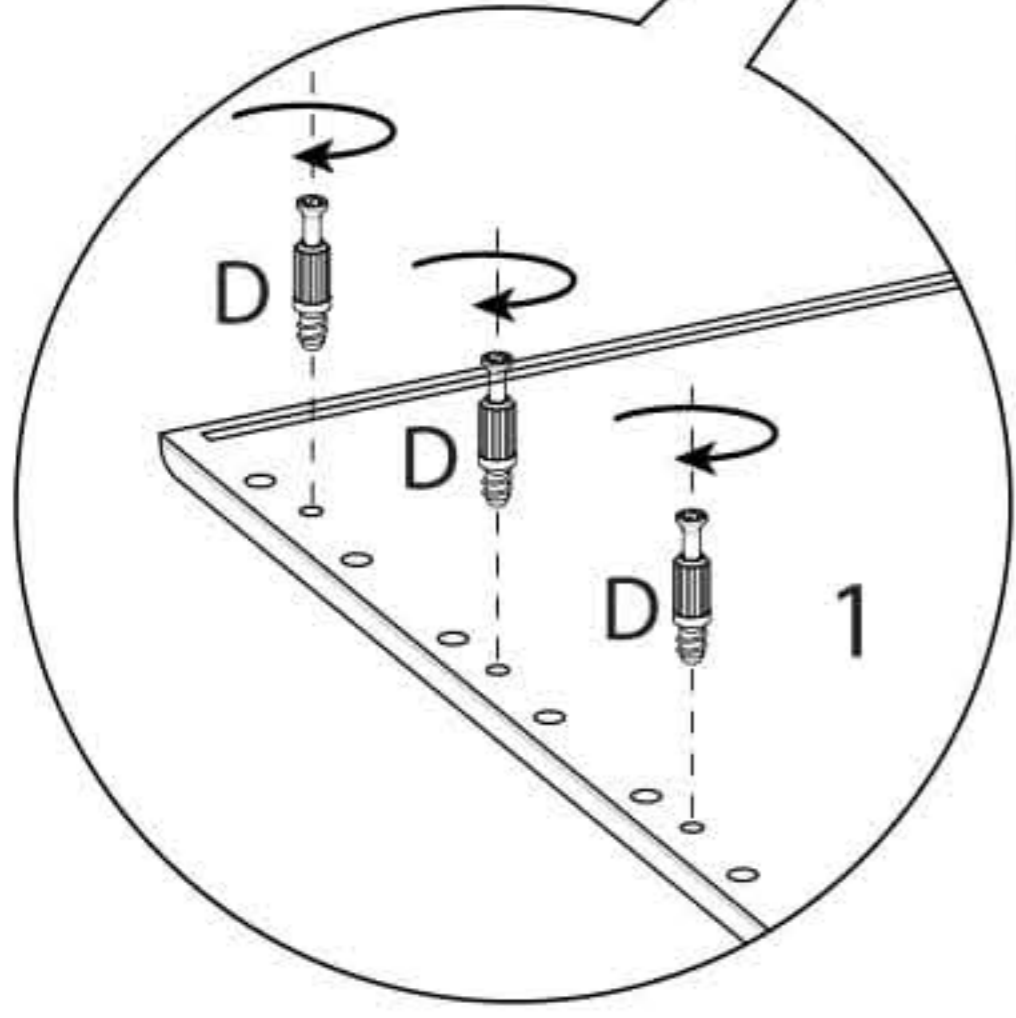
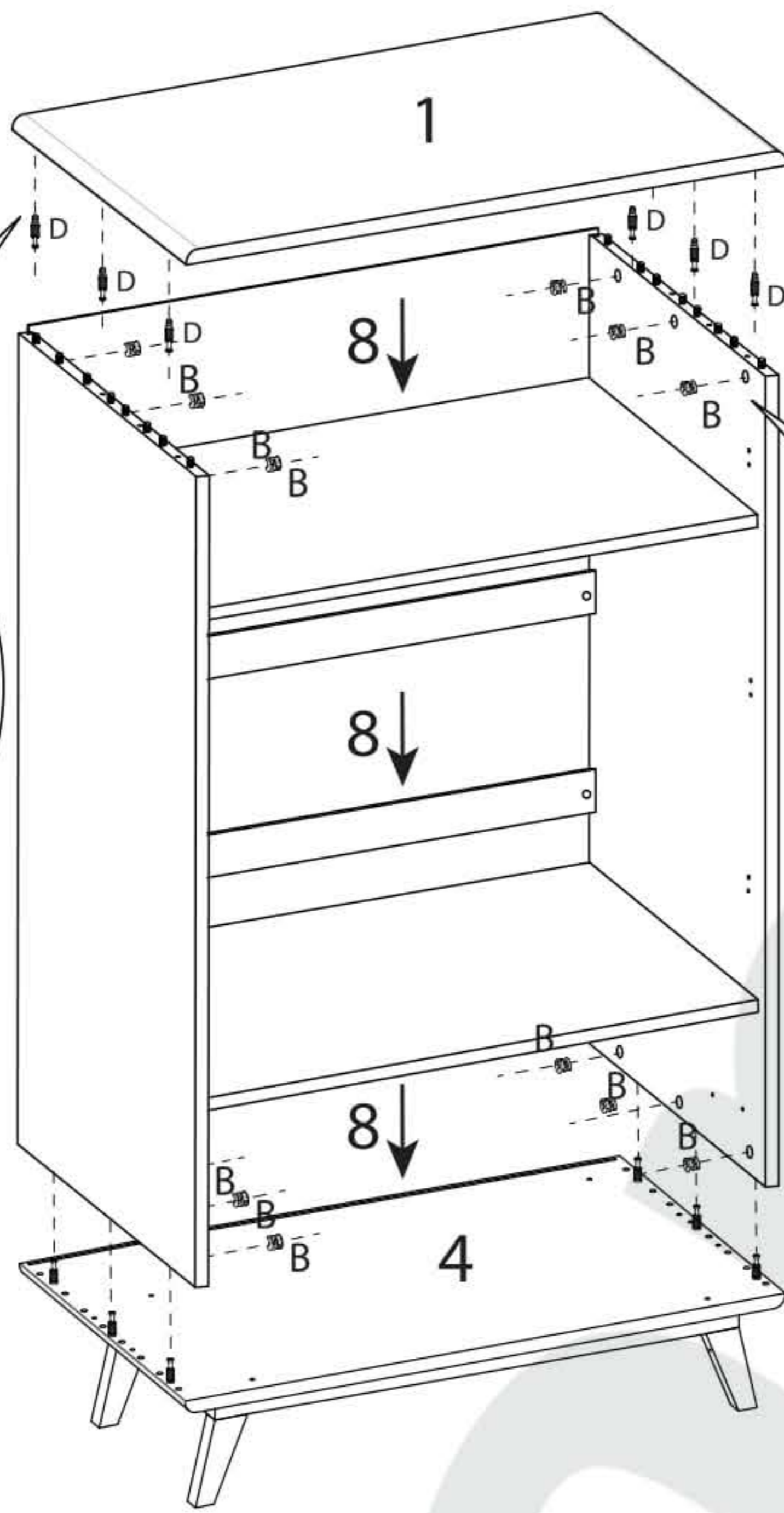

6

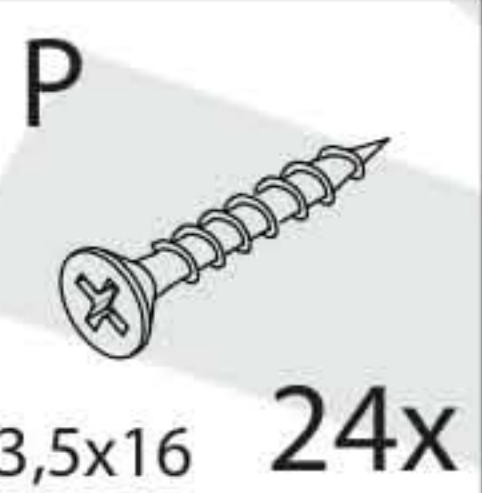
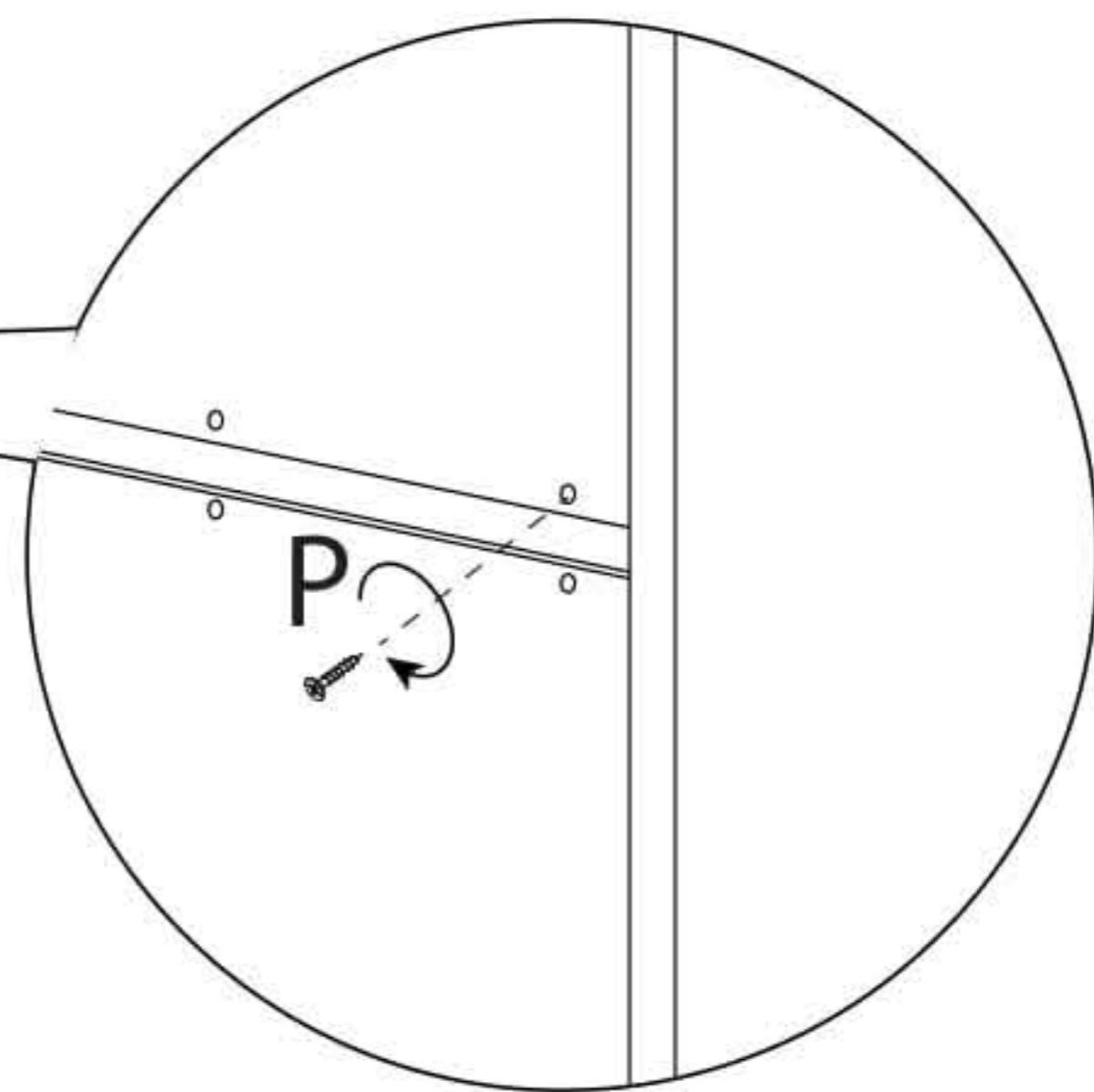
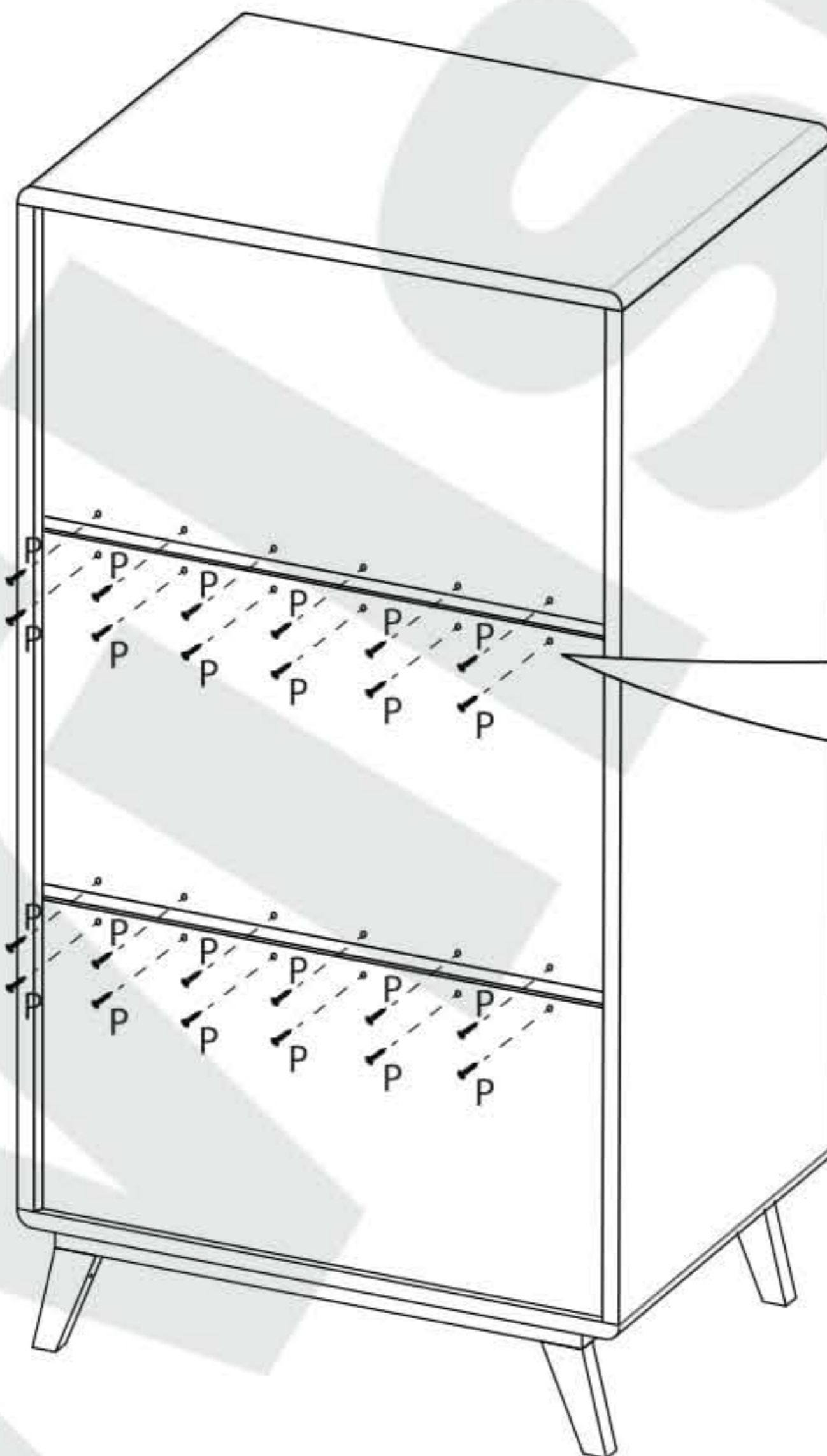

7

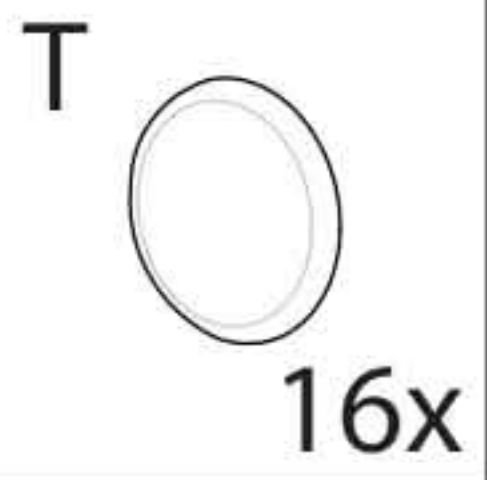
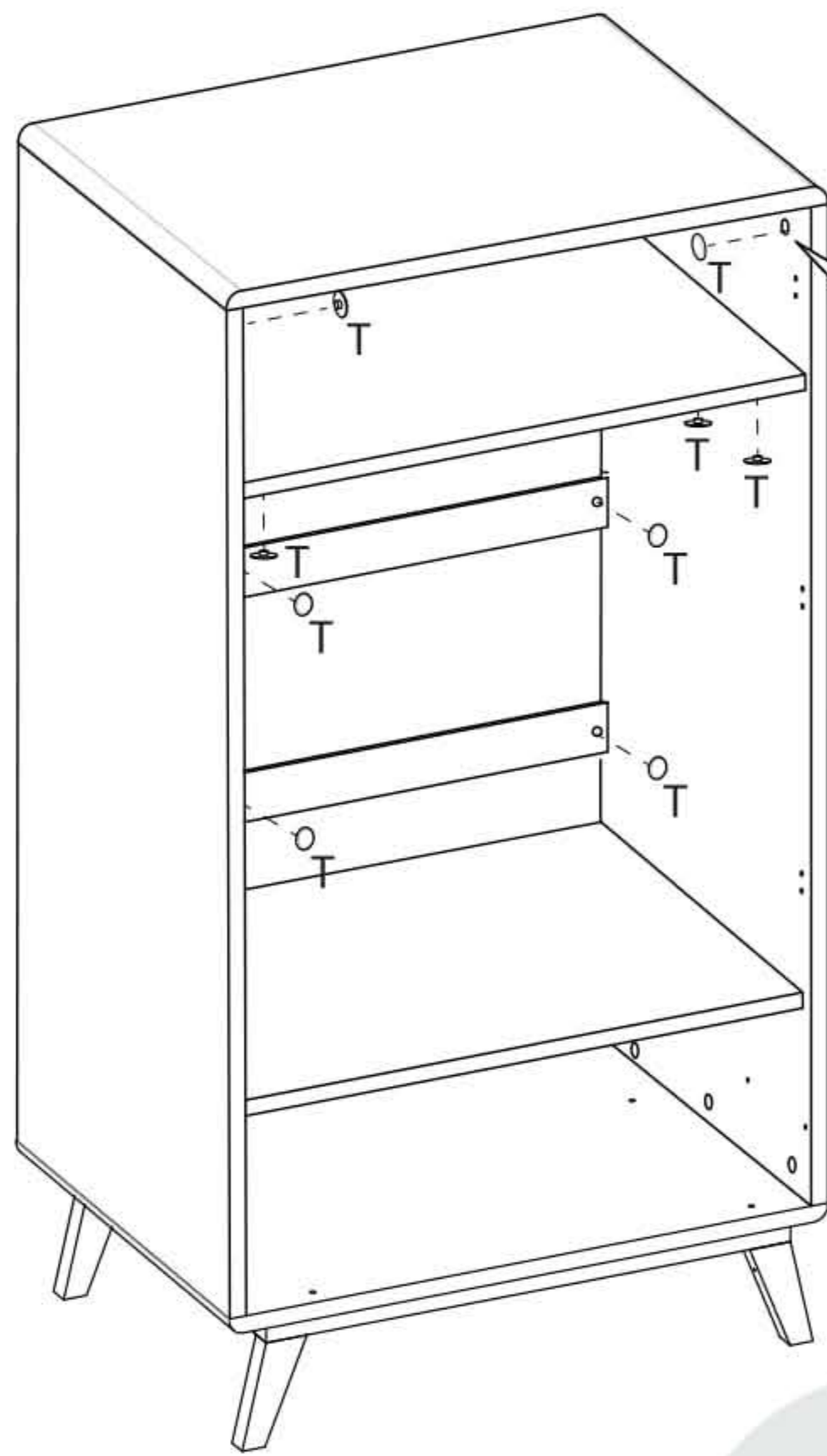

8

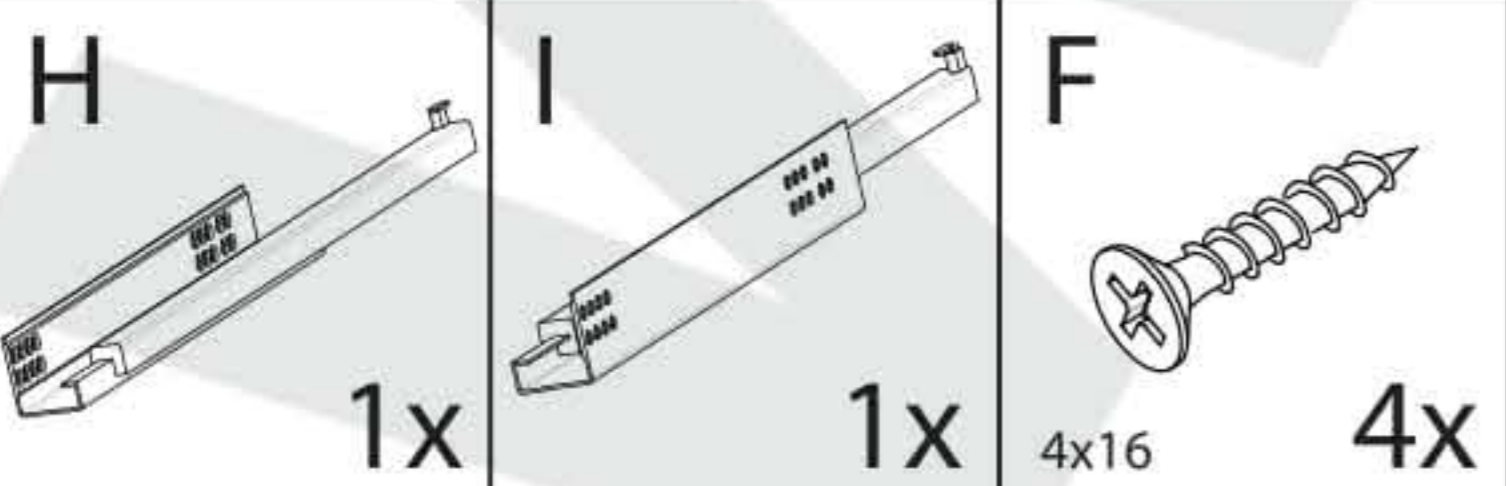
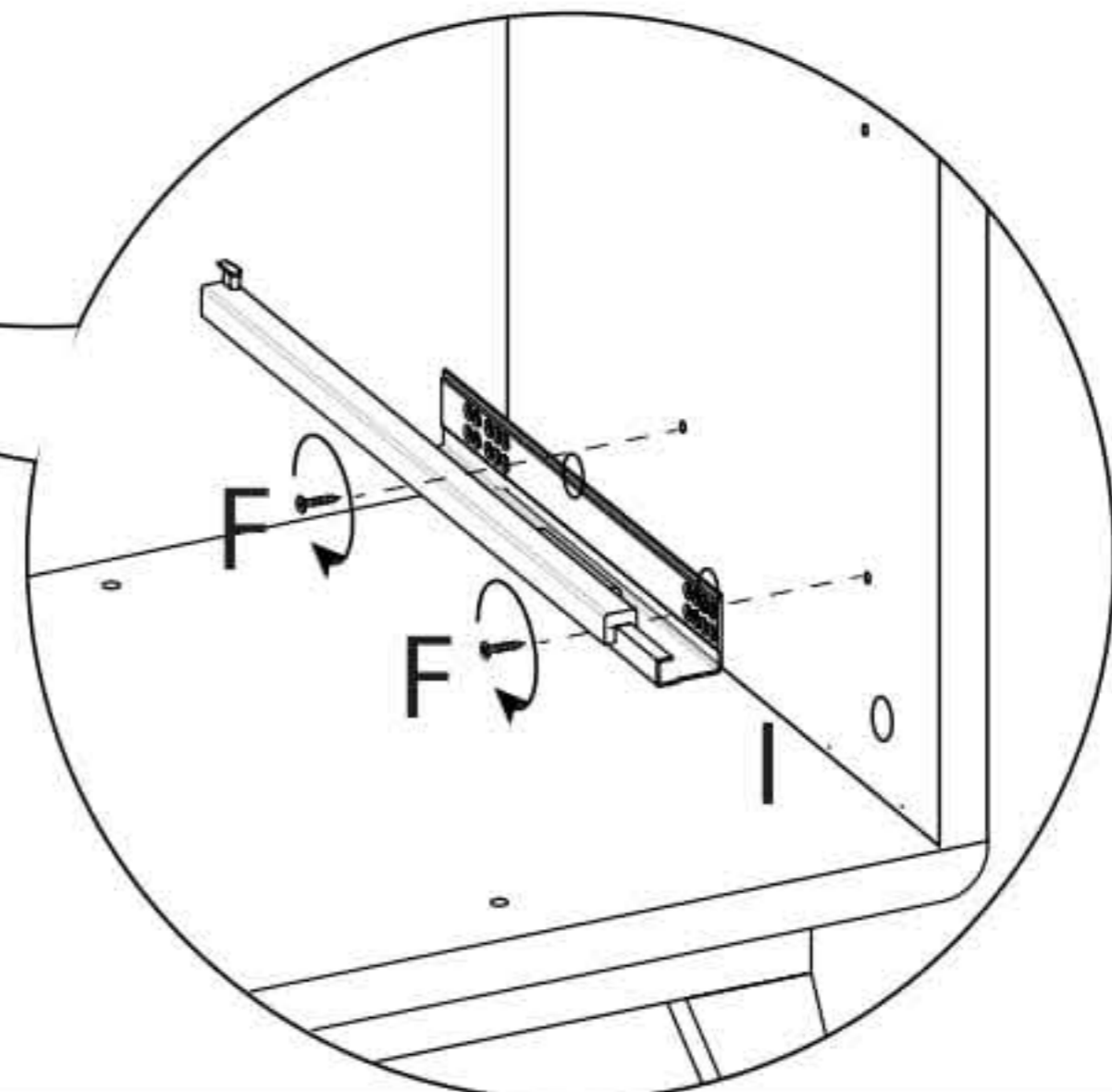
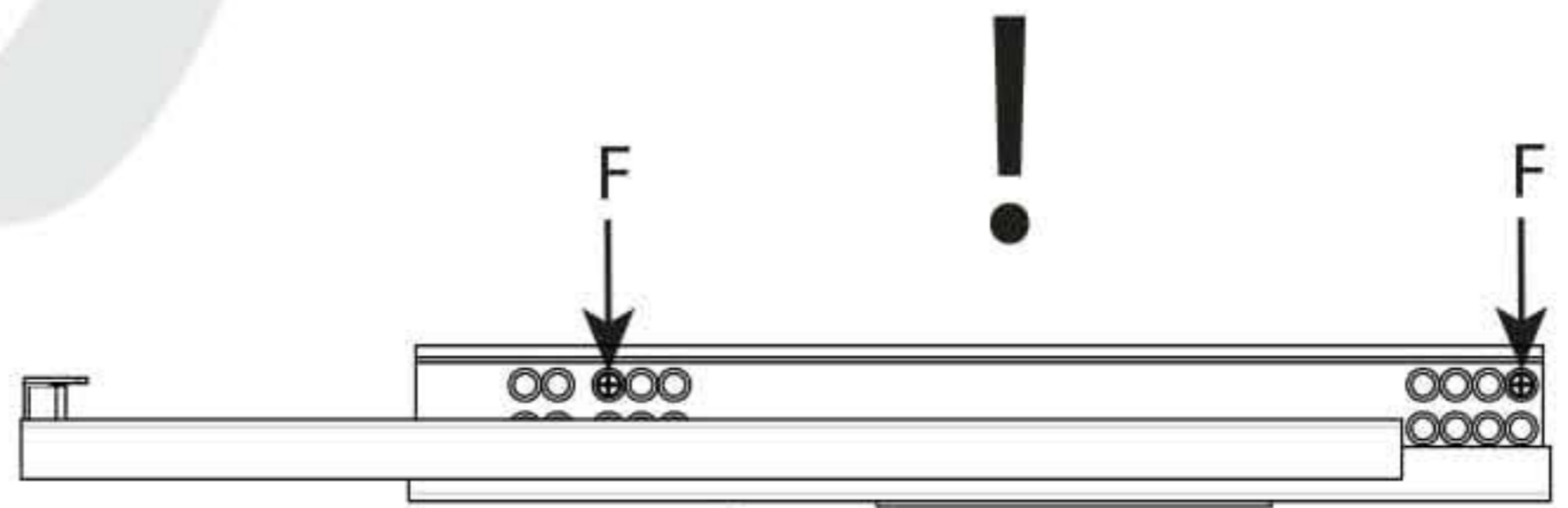
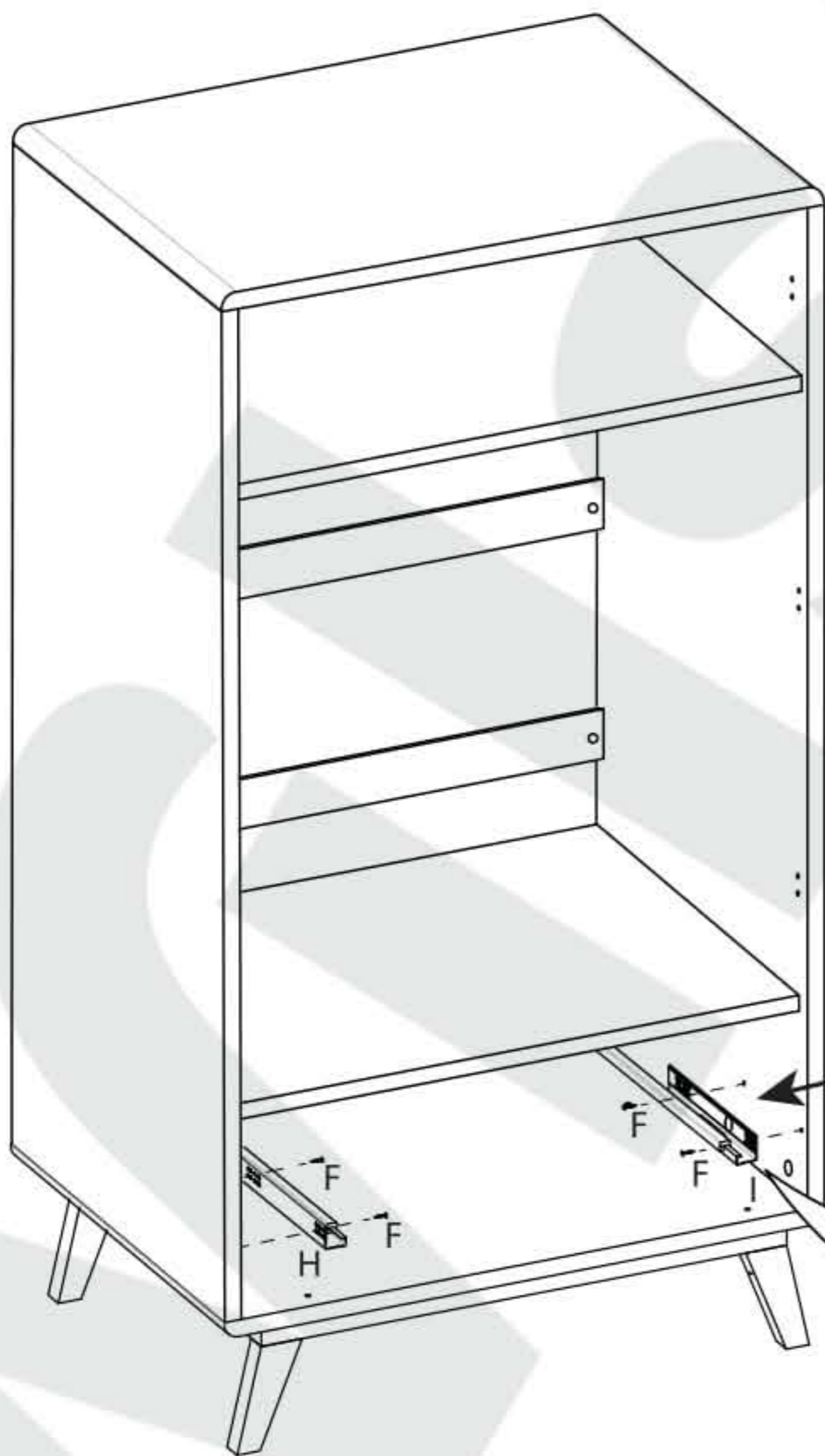

9

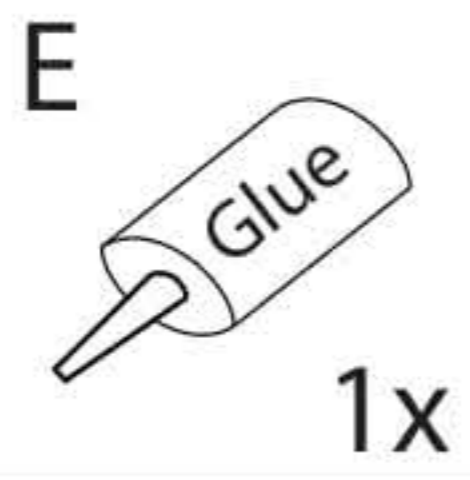
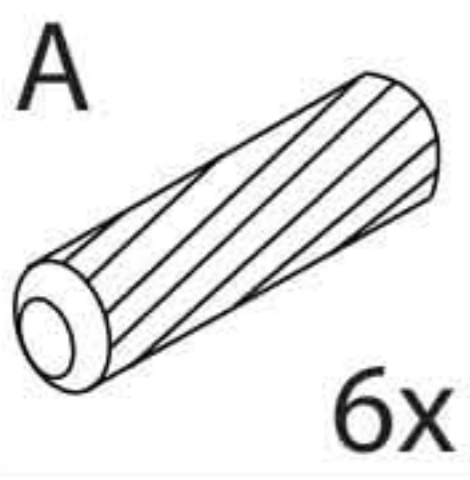
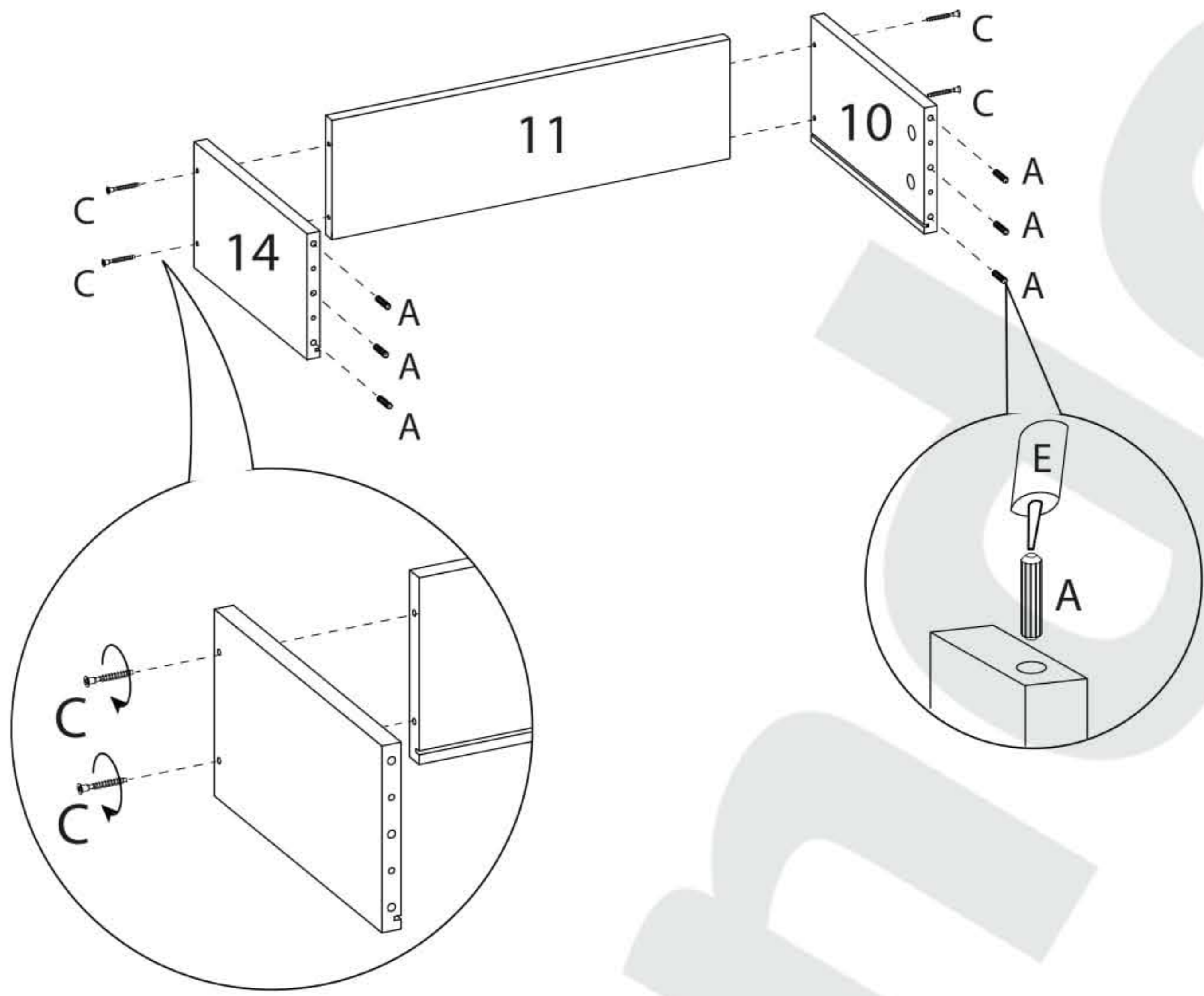

10

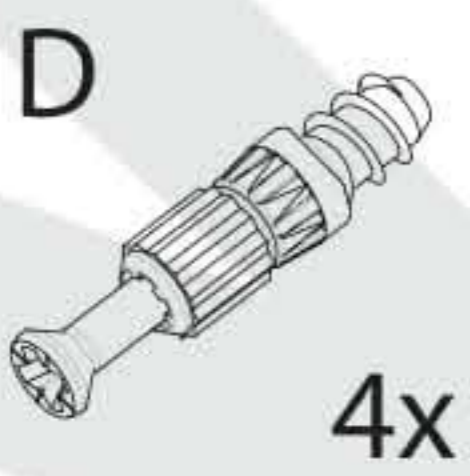
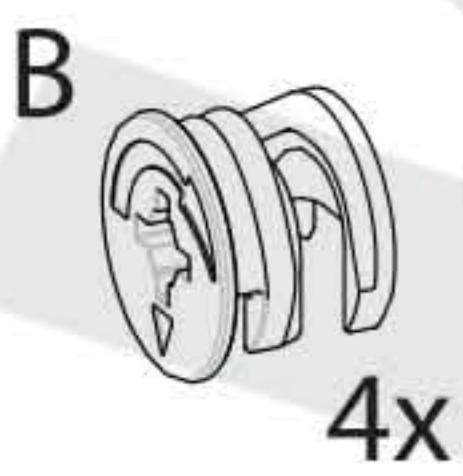
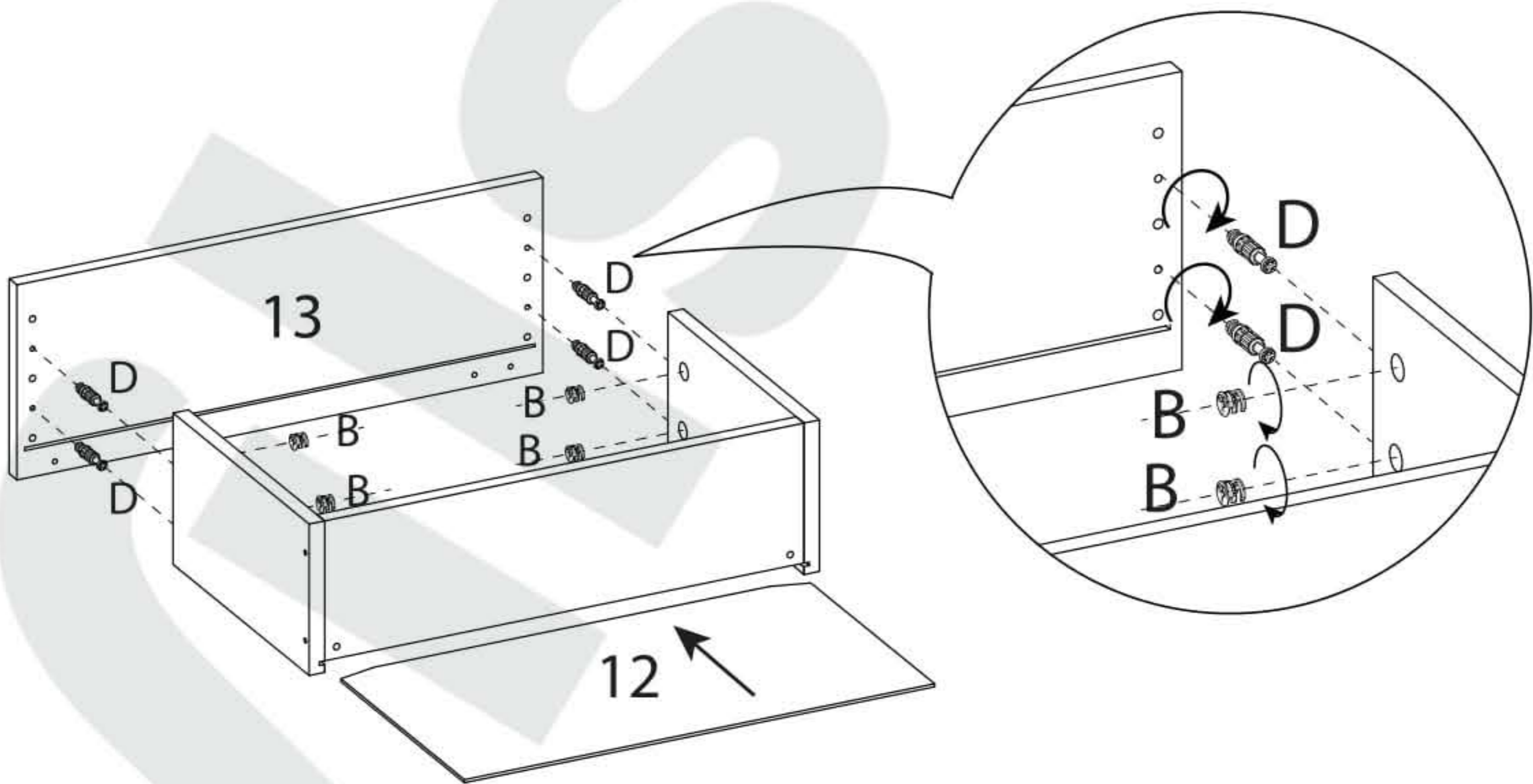

11

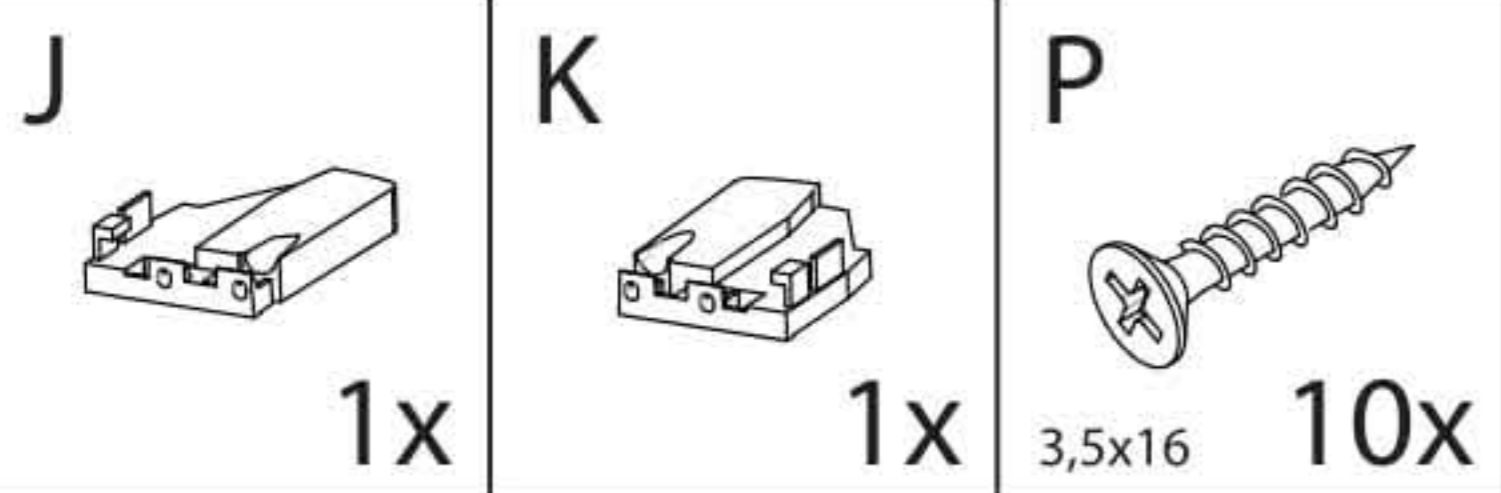
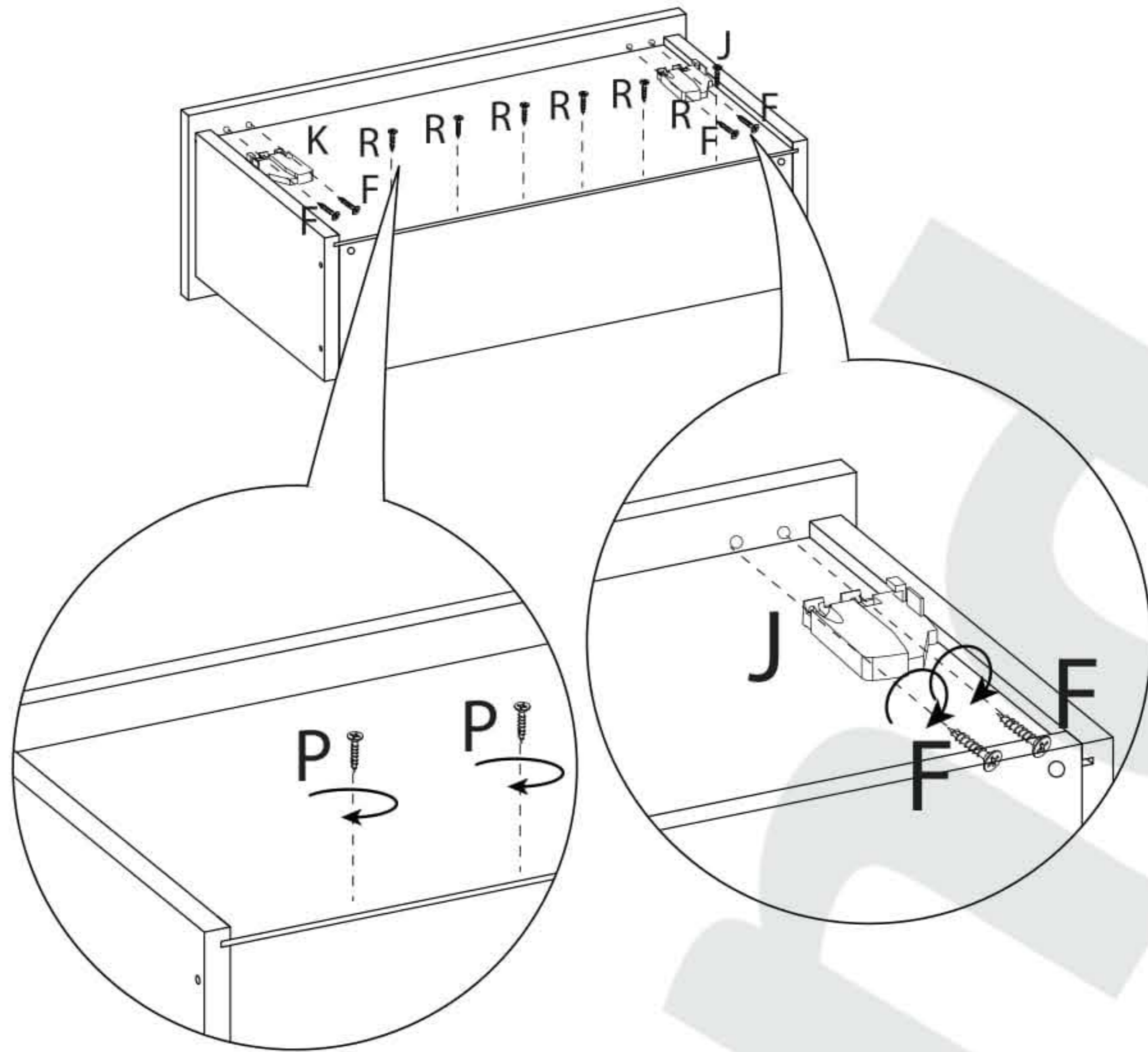

12

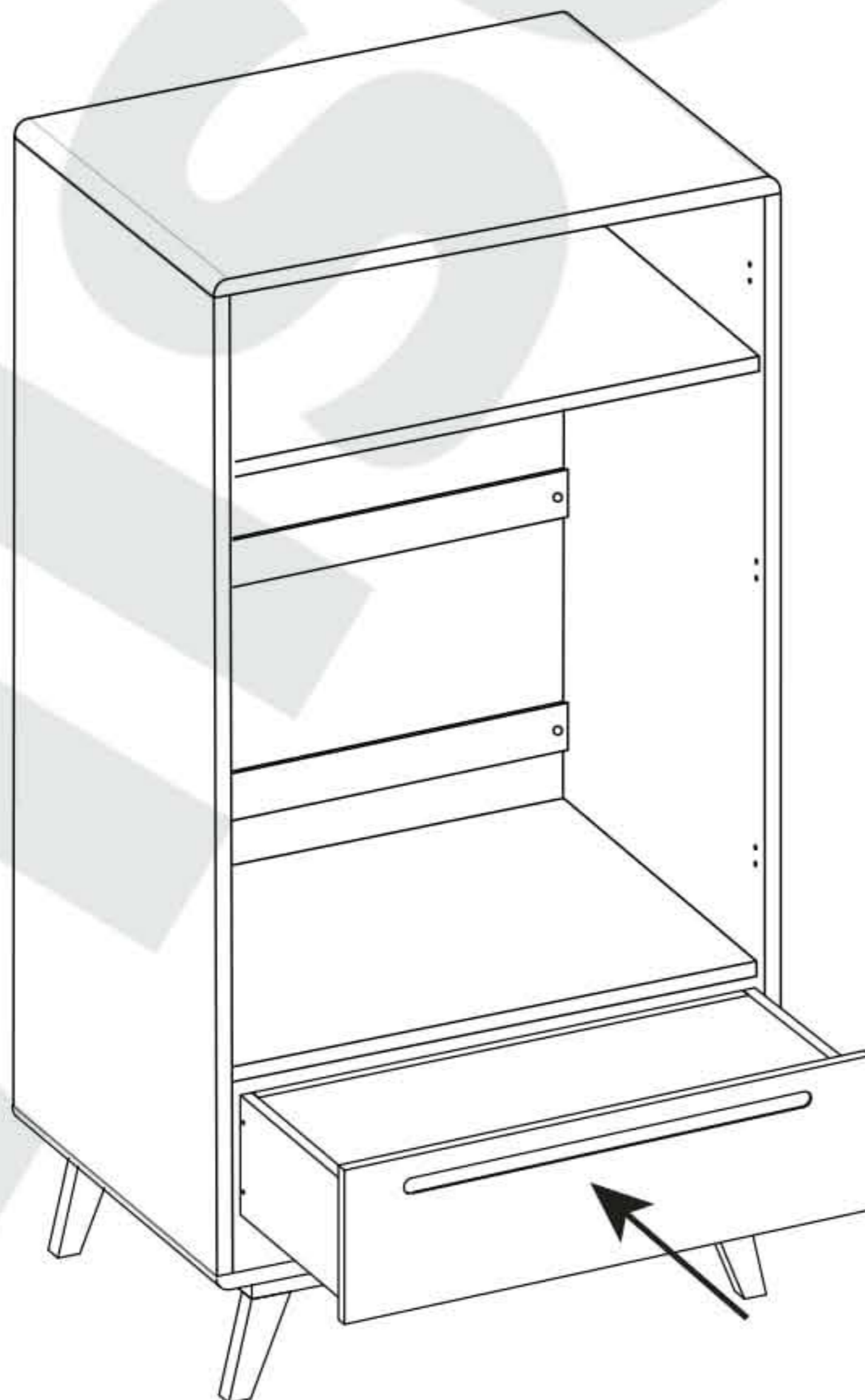

13

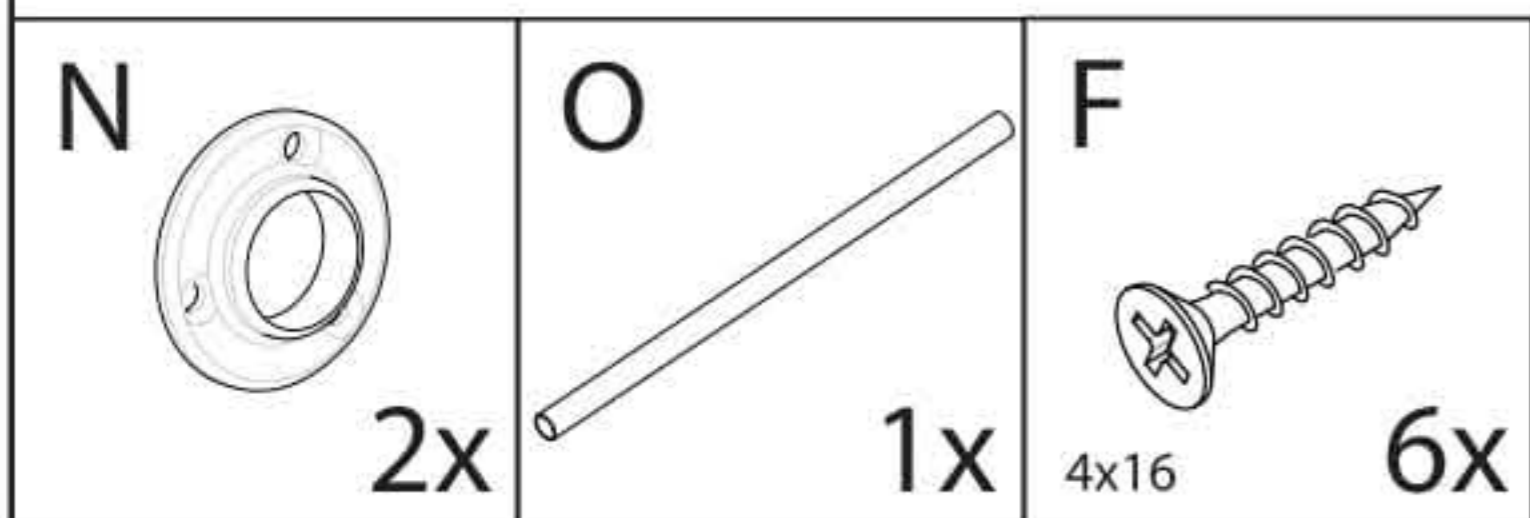
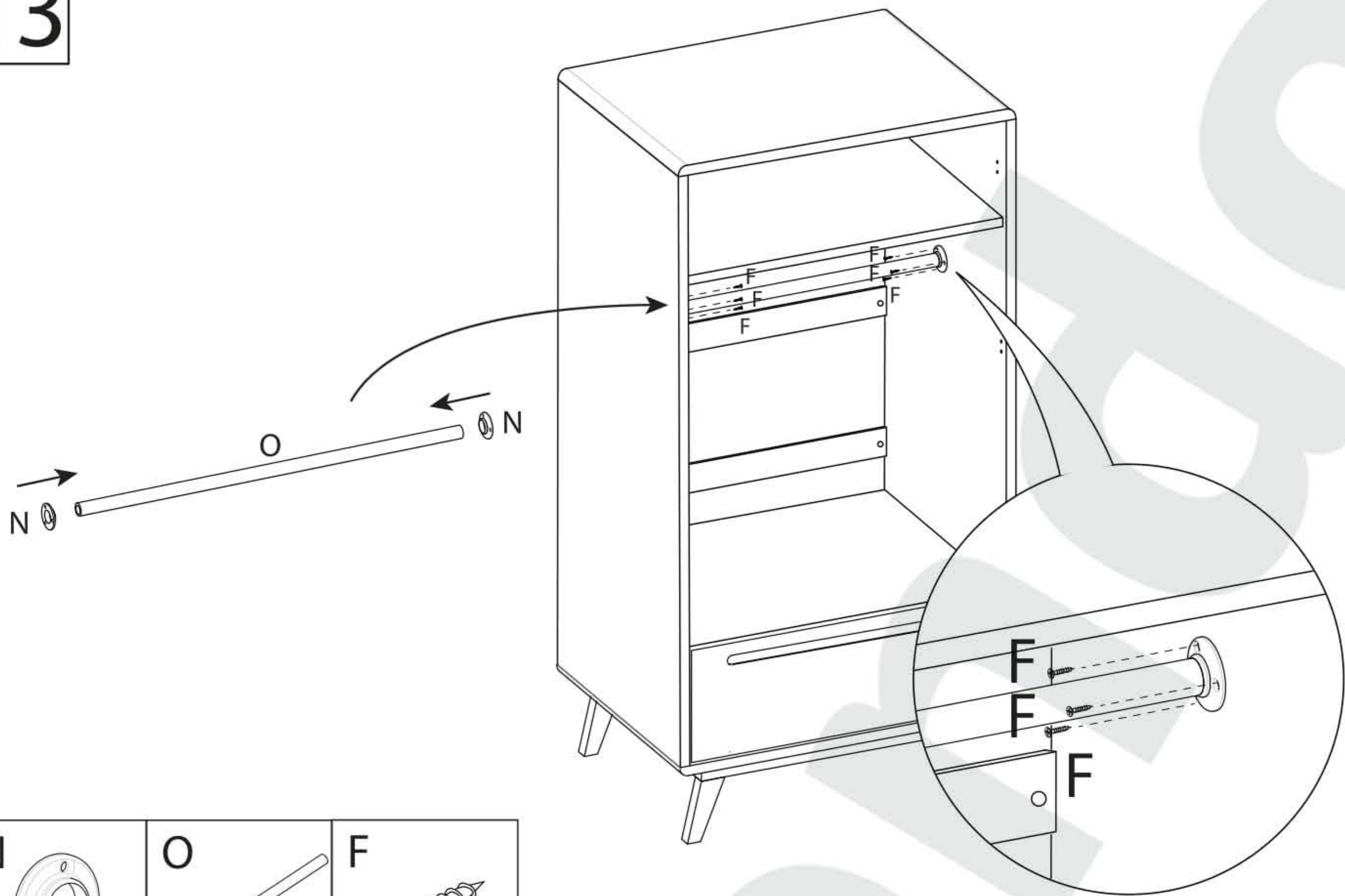

14

